

Safety and operating instructions

Hydraulic breakers

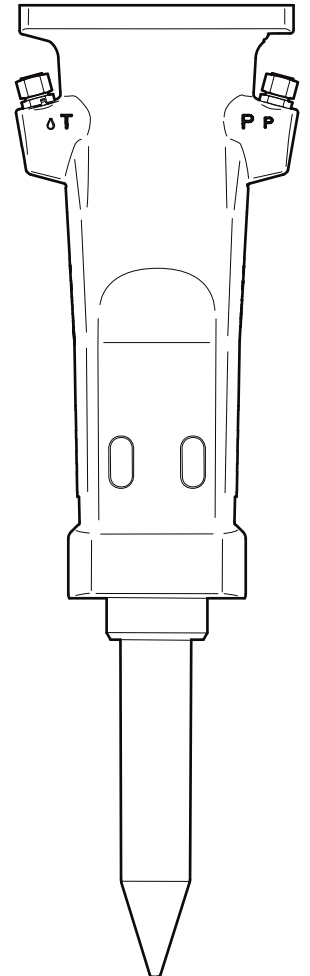

Contents

Introduction.....	5
About the Safety and operating instructions.....	5
Safety instructions.....	6
Safety signal words.....	6
Personal precautions and qualifications.....	6
Transport.....	6
Installation, storage, maintenance and disposal.....	6
Operation.....	6
Testing.....	6
Personal protective equipment.....	6
Drugs, alcohol or medication.....	7
Carrier, precautions.....	7
Installation, precautions.....	7
Hydraulic system.....	7
Assembly / Disassembly.....	7
Operation, precautions.....	7
Maintenance, precautions.....	9
Storage, precautions.....	10
Overview.....	11
Design and function.....	11
Main parts.....	11
Labels.....	11
Data plate.....	12
Noise level label.....	12
Labels on the accumulator.....	12
Transport.....	12
Lifting the hydraulic breaker.....	12
Transport using a forklift.....	12
Transport using a lorry.....	12
Installation.....	13
Hoses and connections.....	13
Hydraulic oil.....	14
Assembly.....	14
Pressure adjustment.....	15
Water flushing.....	16
Working tool.....	16
Selecting the right working tool.....	16
Conical moil point.....	16
Chisels and spades.....	16
Blunt tool.....	16
Changing the working tool.....	16
Operation.....	17
Preparation before breaking.....	17
Operating temperatures.....	17
Engine rpm.....	17
Operating.....	17
Risk area.....	17
Breaking.....	17
Breaking under water.....	19
Heavy duty operation.....	19

Maintenance	20
Every second hour	20
Lubricating with a grease gun	20
Central lubrication system	20
Every day	20
Every week	21
Wear limits	21
Replacing the insertion tool bushing	21
Every year	22
Storage	22
Disposal	22
Troubleshooting	23
Hydraulic breaker does not start	23
Impact force too low	23
Oil leaks	23
Hydraulic breaker operates too slowly	24
Operating temperature too high	24
Technical data	25
Machine data	25
Capacities	26
Noise declaration statement	26
Flow diagrams for the correct operating pressure	27
SB 52: 100–150 bar	27
SB 102: 100–150 bar	28
SB 152: 100–150 bar	28
SB 202: 100–150 bar	29
SB 302: 100–150 bar	29
SB 452: 100–150 bar	30
SB 552: 100–150 bar	30
EC Declaration of Conformity	31
EC Declaration of Conformity (EC Directive 2006/42/EC)	31

Introduction

Thank you for choosing a product from Atlas Copco. Since 1873, we have been committed to finding new and better ways of fulfilling our customers' needs. Through the years, we have developed innovative and ergonomic product designs that have helped customers improve and rationalize their daily work.

Atlas Copco has a strong global sales and service network, consisting of customer centers and distributors worldwide. Our experts are highly trained professionals with extensive product knowledge and application experience. In all corners of the world, we can offer product support and expertise to ensure that our customers can work at maximum efficiency at all times.

For more information please visit: www.atlascopco.com

Construction Tools PC AB
Box 703
391 27 Kalmar
Sweden

About the Safety and operating instructions

The aim of the instructions is to provide you with knowledge of how to use the hydraulic breaker in an efficient, safe way. The instructions also give you advice and tell you how to perform regular maintenance on the hydraulic breaker.

Before using the hydraulic breaker for the first time you must read these instructions carefully and understand all of them.

Safety instructions

To reduce the risk of serious injury or death to yourself or others, read and understand the Safety and operating instruction before installing, operating, repairing, maintaining, or changing accessories on the machine.

Post this Safety and operating instruction at work locations, provide copies to employees, and make sure that everyone reads the Safety and operating instruction before operating or servicing the machine.

In addition, the operator or the operator's employer must assess the specific risks that may be present as a result of each use of the machine.

Safety signal words

The safety signal words Danger, Warning and Caution have the following meanings:

DANGER	Indicates a hazardous situation which, if not avoided, will result in death or serious injury.
WARNING	Indicates a hazardous situation which, if not avoided, could result in death or serious injury.
CAUTION	Indicates a hazardous situation which, if not avoided, could result in minor or moderate injury.

Personal precautions and qualifications

Only qualified and trained persons may operate or maintain the machine. They must be physically able to handle the bulk, weight, and power of the tool. Always use your common sense and good judgement.

Transport

Transport of the hydraulic breaker may only be undertaken by persons who:

- are authorised to operate a crane or fork-lift truck in conformity with the applicable national directives,
- are aware of all the relevant national safety instructions and accident prevention instructions
- and have read and understood the safety and transport chapters of this manual.

Installation, storage, maintenance and disposal

Installation, storage, maintenance and disposal of the hydraulic breaker may only be undertaken by persons who:

- are aware of all the relevant national safety instructions and accident prevention instructions
- and have read and understood the Safety and operating instructions.

Operation

Operation of the hydraulic breaker may only be undertaken by qualified carrier operators. Carrier operators are qualified if they:

- are trained to operate a carrier in conformity with national directives,
- are aware of all the relevant national safety instructions and accident prevention instructions
- and have read and understood the Safety and operating instructions.

Testing

Testing of the hydraulic installation must only be carried out by professional technicians. The technicians must be authorised to approve a hydraulic installation in accordance with national directives.

Personal protective equipment

Always use approved protective equipment. Operators and all other persons in the working area must wear protective equipment, including at a minimum:

- Protective helmet
- Hearing protection
- Impact resistant eye protection with side protection
- Respiratory protection when appropriate
- Protective gloves
- Proper protective boots
- Appropriate work overall or similar clothing (not loose-fitting) that covers your arms and legs.

Drugs, alcohol or medication

▲ **WARNING** Drugs, alcohol or medication

Drugs, alcohol or medication may impair your judgment and powers of concentration. Poor reactions and incorrect assessments can lead to severe accidents or death.

- ▶ Never use the machine when you are tired or under the influence of drugs, alcohol or medication.
- ▶ No person who is under the influence of drugs, alcohol or medication may operate the machine.

Carrier, precautions

Before using or transporting the carrier with the hydraulic breaker attached, carefully read the carrier manufacturer's safety regulations and operating instructions.

Make sure that the carrier is equipped with adequate protective features, including a protective screen in front of the operator.

The hydraulic breaker must only be mounted on a carrier with sufficient load capacity.

Carriers without sufficient load capacity will not provide the required degree of stability and could even fall over during hydraulic breaker use, causing injury and damage.

Installation, precautions

Hydraulic system

▲ **DANGER** Compressed gas, explosion hazard

The accumulator is pressurized even when the hydraulic system is shut off. To dismantle the accumulator without first releasing the nitrogen gas can cause serious personal injury or death.

- ▶ Fill the high-pressure accumulator with nitrogen (N₂) only.
- ▶ Only authorised personnel are qualified to work with the accumulator.

▲ **WARNING** Hydraulic oil at high pressure

Thin jets of hydraulic oil under high pressure can penetrate the skin and cause permanent injury.

- ▶ Immediately consult a doctor if hydraulic oil has penetrated the skin.
- ▶ Never use your fingers to check for hydraulic fluid leaks.
- ▶ Keep your face away from any possible leaks.

▲ **WARNING** Hydraulic oil

Spilled hydraulic oil can cause burns, accidents due to slippery conditions and will also harm the environment.

- ▶ Take care of all spilled oil and handle it according to your safety and environmental regulations.
- ▶ Never dismantle the hydraulic machine when the hydraulic oil is hot.
- ▶ Never run any hydraulic lines for attachment of the hydraulic machine through the drivers cab.

▲ **CAUTION** Skin eczema

Hydraulic oil can cause eczema if it comes in contact with the skin.

- ▶ Avoid getting hydraulic oil on your hands.
- ▶ Always use protective gloves when working with hydraulic oil.
- ▶ Wash hands after contact with hydraulic oil.

Assembly / Disassembly

▲ **WARNING** Moving parts

Risk for leaking oil and personal injury, such as crushed hands and fingers.

- ▶ Never check bores or passages with hands or fingers.
- ▶ Any boom movements must only be done in cooperation with the personnel mounting the hydraulic breaker.
- ▶ If the hydraulic breaker is mounted on a quick hitch coupling, make sure it is locked securely and all risks of the hydraulic breaker coming loose are eliminated.

Operation, precautions

▲ **DANGER** Explosion hazard

If an working tool comes into contact with explosives or explosive gases, an explosion could occur. When working on certain materials and when using certain materials in machine parts, sparks and ignition can occur. Explosions will lead to severe injuries or death.

- ▶ Never operate the machine in any explosive environment.
- ▶ Never use the machine near flammable materials, fumes or dust.
- ▶ Make sure that there are no undetected sources of gas or explosives.

▲ WARNING Operating pressure

If the maximum operating pressure for the hydraulic machine is exceeded, the accumulator can be over charged which can result in material damage and personal injury.

- ▶ Always run the hydraulic machine with the correct operating pressure. See "Technical data".

▲ WARNING Dust and fume hazard

Dusts and/or fumes generated or dispersed when using the machine may cause serious and permanent respiratory disease, illness, or other bodily injury (for example, silicosis or other irreversible lung disease that can be fatal, cancer, birth defects, and/or skin inflammation).

Some dusts and fumes created by drilling, breaking, hammering, sawing, grinding and other construction activities contain substances known to the State of California and other authorities to cause respiratory disease, cancer, birth defects, or other reproductive harm. Some examples of such substances are:

- Crystalline silica, cement, and other masonry products.
- Arsenic and chromium from chemically-treated rubber.
- Lead from lead-based paints.

Dust and fumes in the air can be invisible to the naked eye, so do not rely on eye sight to determine if there is dust or fumes in the air.

To reduce the risk of exposure to dust and fumes, do all of the following:

- ▶ Perform site-specific risk assessment. The risk assessment should include dust and fumes created by the use of the machine and the potential for disturbing existing dust.
- ▶ Use proper engineering controls to minimize the amount of dust and fumes in the air and to minimize build-up on equipment, surfaces, clothing, and body parts. Examples of controls include: exhaust ventilation and dust collection systems, water sprays, and wet drilling. Control dusts and fumes at the source where possible. Make sure that controls are properly installed, maintained and correctly used.
- ▶ Wear, maintain and correctly use respiratory protection as instructed by your employer and as required by occupational health and safety regulations. The respiratory protection must be effective for the type of substance at issue (and if applicable, approved by relevant governmental authority).
- ▶ Work in a well ventilated area.

- ▶ If the machine has an exhaust, direct the exhaust so as to reduce disturbance of dust in a dust filled environment.
- ▶ Operate and maintain the machine as recommended in the operating and safety instructions
- ▶ Select, maintain and replace consumables/ working tools/ other accessories as recommended in the operating and safety instructions. Incorrect selection or lack of maintenance of consumables/ inserted tools/ other accessories may cause an unnecessary increase in dust or fumes.
- ▶ Wear washable or disposable protective clothes at the worksite, and shower and change into clean clothes before leaving the worksite to reduce exposure of dust and fumes to yourself, other persons, cars, homes, and other areas.
- ▶ Avoid eating, drinking, and using tobacco products in areas where there is dust or fumes.
- ▶ Wash your hands and face thoroughly as soon as possible upon leaving the exposure area, and always before eating, drinking, using tobacco products, or making contact with other persons.
- ▶ Comply with all applicable laws and regulations, including occupational health and safety regulations.
- ▶ Participate in air monitoring, medical examination programs, and health and safety training programs provided by your employer or trade organizations and in accordance with occupational health and safety regulations and recommendations. Consult with physicians experienced with relevant occupational medicine.
- ▶ Work with your employer and trade organization to reduce dust and fume exposure at the worksite and to reduce the risks. Effective health and safety programs, policies and procedures for protecting workers and others against harmful exposure to dust and fumes should be established and implemented based on advice from health and safety experts. Consult with experts.
- ▶ Residues of hazardous substances on the machine can be a risk. Before undertaking any maintenance on the machine, clean it thoroughly.

▲ WARNING Electric shock

The hydraulic breaker is not insulated against electric current. If the hydraulic breaker come in contact with electric circuits or other electrical power sources, there is a risk of severe injury or death.

- ▶ Never work in the proximity of electric circuits or other electrical power sources.
- ▶ Make sure there are no hidden electric circuits in your working area.

▲ WARNING Projectiles

Failure of the work piece, of accessories, or even of the hydraulic breaker itself may generate high velocity projectiles. During breaking, splinters, or other particles may become projectiles and cause bodily injury by striking the operator or other persons. Also, breakage of the work piece, accessories, or the working tool may generate high velocity projectiles that can cause bodily injury. In addition, objects falling from a height can cause bodily injury. To reduce risks:

- ▶ Close off the working area.
- ▶ Before starting, make sure that no persons are in the danger area, 20 meters both horizontally and vertically from the hydraulic breaker.
- ▶ Immediately switch off the hydraulic breaker when persons are present in the danger area.
- ▶ Press the working tool against the working surface before you start.
- ▶ Never operate unless the working tool is retained in the hydraulic breaker with a proper tool retainer.

▲ WARNING Noise hazard

High noise levels can cause permanent and disabling hearing loss and other problems such as tinnitus (ringing, buzzing, whistling, or humming in the ears). To reduce risks and prevent an unnecessary increase in noise levels:

- ▶ Risk assessment of these hazards and implementation of appropriate controls is essential.
- ▶ Operate and maintain the machine as recommended in these instructions.
- ▶ Select, maintain and replace the working tool as recommended in these instructions.
- ▶ If the machine has a silencer, check that it is in place and in good working condition.
- ▶ Always use hearing protection.
- ▶ Use damping material to prevent work pieces from 'ringing'.

Maintenance, precautions**▲ WARNING Involuntary start**

An involuntary start of the hydraulic breaker can lead to severe injuries.

- ▶ Follow the instructions in the carrier manual to prevent involuntary start of the hydraulic breaker.
- ▶ Installation of a start circuit on the hydraulic breaker must be made in a way that avoids any unintentional starts.
- ▶ A foot pedal on the carrier must be equipped with a protection cover.

▲ WARNING Hydraulic system under high pressure

Maintenance work on a hydraulic breaker under pressure can lead to severe injuries. Connections can loosen suddenly, parts can suddenly move and hydraulic oil can be ejected.

- ▶ Depressurise the hydraulic system before performing maintenance on the hydraulic breaker or the carrier.

▲ WARNING Machine modification

Any machine modification may result in bodily injuries to yourself or others.

- ▶ Never modify the machine. Modified machines are not covered by warranty or product liability.
- ▶ Always use original parts, working tools and accessories approved by Atlas Copco.
- ▶ Change damaged parts immediately.
- ▶ Replace worn components in good time.

▲ CAUTION Hot insertion tool

The tip of the insertion tool can become hot and sharp when used. Touching it can lead to burns and cuts.

- ▶ Never touch a hot or sharp insertion tool.
- ▶ Wait until the insertion tool has cooled down before carrying out maintenance work.

▲ WARNING Working tool hazards

Accidental engagement of the start and stop device during maintenance or installation can cause serious injuries, when the power source is connected.

- ▶ Never inspect, clean, install, or remove the working tool while the power source is connected.

Storage, precautions

▲ WARNING Hydraulic breaker and working tool are heavy

If the breaker or working tool topple over or fall down it can result in material damage and personal injury.

- ▶ Store the hydraulic breaker and the working tool so that falling or rolling down is prevented.

Overview

To reduce the risk of serious injury or death to yourself or others, read the Safety instructions section found on the previous pages of this manual before operating the machine.

Design and function

SB is a range of rig mounted hydraulic breakers designed for all kinds of demolition works. No other use is permitted.

SB has a solid body which means that the breaker body is made in one piece. The accumulator is integrated with the body.

The hydraulic breaker is operated from the driver's cab of the carrier using the carrier's hydraulic system. The breaker frequency is controlled by the oil flow from the carrier.

Recommended working tools are listed in the spare parts list.

Main parts

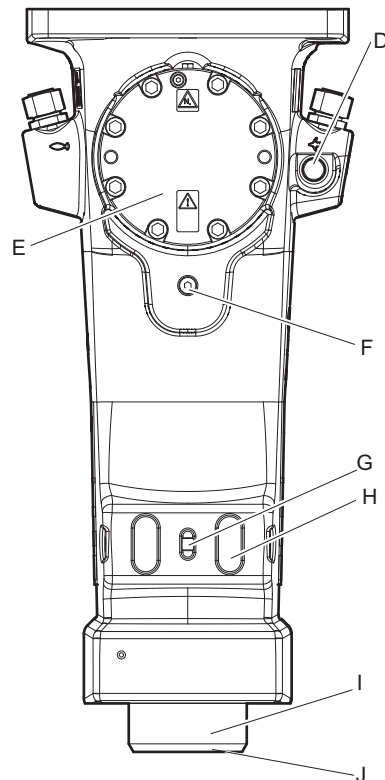
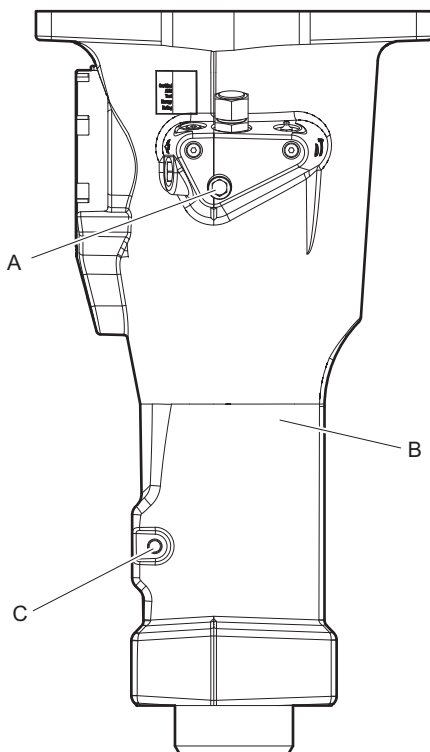

- A. Restrictor
- B. Hammer body
- C. Lock pin
- D. Pressure relief valve
- E. Accumulator
- F. Oil drainage plug
- G. Lock buffer
- H. Tool retainer
- I. Bushing
- J. Scraper ring

Labels

The machine is fitted with labels containing important information about personal safety and machine maintenance. The labels must be in such condition that they are easy to read. New labels can be ordered from the spare parts list.

Data plate

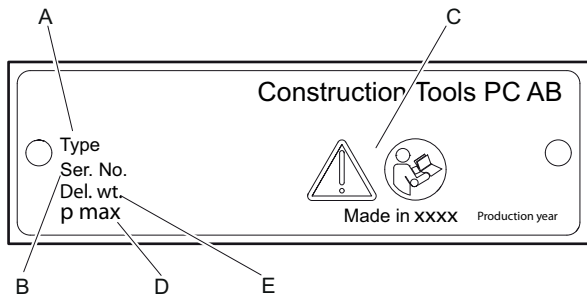

- A. Machine type
- B. Maximum hydraulic pressure
- C. Serial number
- D. The warning symbol together with the book symbol means that the user must read the safety and operating instructions before the machine is used for the first time.
- E. The CE symbol means that the machine is EC-approved. See the EC Declaration of Conformity which is delivered with the machine for more information.

Noise level label

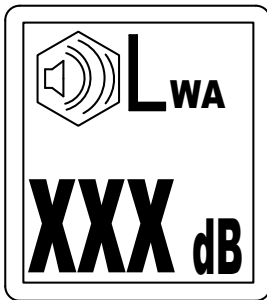

The label indicates the guaranteed noise level corresponding to EC-directive 2000/14/EC. See "Technical data" for accurate noise level.

Labels on the accumulator



Read through the overhaul instructions carefully before servicing or charging.



The accumulator must only be charged with Nitrogen.
NOTICE Only certified personnel are allowed to work with the accumulator.

Transport

▲ WARNING Falling hydraulic breaker

If the hydraulic breaker tips over and fall, it may cause serious injury.

- ▶ Place the hydraulic breaker in a safe position where it cannot fall over and cause damage.

Lifting the hydraulic breaker

Carefully check that the carrier is stable enough when transporting, performing maintenance, or other kinds of work with the hydraulic breaker.

The hydraulic breaker is delivered in a box. To lift the hydraulic breaker in a safe way, fit the lifting strap in the manner shown in the illustration below.

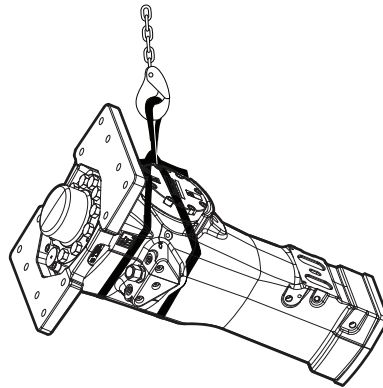

Transport using a forklift

When using a forklift. Place the hydraulic breaker at a pallet. Use wedges and strapping to secure it. Slowly lift and transport the hydraulic breaker to its intended destination.

Transport using a lorry

Put the hydraulic breaker on an anti-slip mat at the lorry. Secure the machine to the loading surface with straps.

Observe all the applicable national and regional regulations on securing loads.

Installation

Before installing the hydraulic breaker on the carrier or operating it, read the operation manual and safety instructions provided by the carrier manufacturer. Follow all instructions.

The carrier must have the appropriate hydraulic system for operation of the breaker.

If the carrier is too large for the hydraulic breaker it may lead to broken working tools and increased wear. See "Technical data" for choosing suitable carrier.

The safety equipment in the hydraulic system must be checked for quality (CE mark, etc.), suitability and functionality by a professional or authorised supervisor before use.

Hoses and connections

▲ WARNING Whipping hydraulic hose

Hydraulic hoses under pressure can whip uncontrollably if screws loosen or are loosened. A whipping hydraulic hose can cause severe injuries.

- ▶ Depressurise the hydraulic system before loosening the connection of a hydraulic hose.
- ▶ Tighten the nuts on the connections of the hydraulic hoses to the required torque.



Type of nipple: ORFS standard nipple. The nipple dimensions can be found in the Spare parts list.

The quality of the hydraulic hoses must be 2SC (according to EN 857) or better when connecting the breaker to the carrier. If quick couplings are to be used, we recommend using the 'Flat Face' quick coupling. This type is sturdy and easy to clean. The quick coupling pressure class must agree with the carrier's working pressure.

Always clean the quick couplings before mounting or dismantling. Always plug hoses and hose nipples with tight and clean end caps when dismantling.



Hose connections

Right (As seen from operator's seat)

	Air flushing	Central lubrication	Tank, return line
Symbol			
SB 52	G ¼ in.	G ¼ in.	G ¾ in.
SB 102	G ¼ in.	G ¼ in.	G ½ in.
SB 152	G ¼ in.	G ¼ in.	G ½ in.
SB 202	G ¼ in.	G ¼ in.	G ½ in.
SB 302	G ¼ in.	G ¼ in.	G ¾ in.
SB 302 SC	G ¼ in.	G ¼ in.	G ¾ in.
SB 452	G ¼ in.	G ¼ in.	G ¾ in.
SB 452 SC	G ¼ in.	G ¼ in.	G ¾ in.
SB 552	G ¼ in.	G ¼ in.	G 1 in.

Hose connections

Left (As seen from operator's seat)

	Water	Pressure to breaker	Pressure for ContiLube II micro
Symbol			
SB 52	-	G ¾ in.	G ¼ in.
SB 102	-	G ½ in.	G ¼ in.
SB 152	G ¼ in.	G ½ in.	G ¼ in.
SB 202	G ¼ in.	G ½ in.	G ¼ in.
SB 302	G ¼ in.	G ¾ in.	G ¼ in.
SB 302 SC	G ¼ in.	G ¾ in.	G ¼ in.
SB 452	G ¼ in.	G ¾ in.	G ¼ in.
SB 452 SC	G ¼ in.	G ¾ in.	G ¼ in.
SB 552	G ¼ in.	G 1 in.	G ¼ in.

Tightening torque for pressure and return hoses

SB 52	60 Nm
SB 102	150 Nm
SB 152	150 Nm
SB 202	150 Nm
SB 302	210 Nm
SB 302 SC	210 Nm
SB 452	210 Nm
SB 452 SC	210 Nm
SB 552	300 Nm

NOTICE The tightening torques in the table above are valid when the pressure and return hose are mounted directly on the hydraulic breaker's connection nipple. If the pressure and return hose are connected with an additional connection nipple, another tightening torques must be used.

Hydraulic oil

Normally the type of hydraulic oil the carrier is using also works for the hydraulic breaker. When a hydraulic breaker is connected to the carrier, the hydraulic oil will get dirty faster. Check and follow the carrier's instructions for changing oil and oil filter. It is common to change the oil filter more frequent when a hydraulic breaker is installed.

SB hydraulic breakers are equipped with an oil drainage plug to drain all oil before dismounting. This is to reduce the risk of spilling oil.

NOTICE When the SB breaker is delivered it contains some mineral based hydraulic oil. Before connecting to the carrier's hydraulic system, check which type of hydraulic oil the carrier is using. Mixing different types of hydraulic oil may destroy the lubrication quality which can lead to machine damage.

In order to protect the environment we recommend the use of biologically degradable hydraulic oil.

Viscosity	
Viscosity (permitted)	15-100 cSt

NOTICE Always use clean oil and filling equipment.

Assembly

Circulate the hydraulic oil before connecting the hydraulic breaker. This is to make sure that the hydraulic oil is clean. Use the same routine when changing the hydraulic oil hose. For further information see section "Hydraulic oil".

1. Connect the pressure and return hoses.



2. Run the hydraulic oil through the carrier's oil filter for approximately 3 minutes to make sure that the hoses are clean.

Preparation

1. Place the breaker in a position where it is easy and safe to mount the adapter plate.

NOTICE Mount the breaker so that the accumulator faces the operator's cabin, to reduce the risk of accumulator damage.

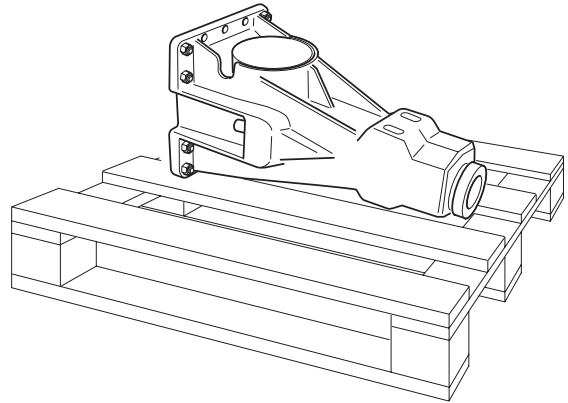

Mounting the adapter plate

1. Place the adapter plate on the hydraulic breaker.
2. Place NYLOK BLUE PATCH™ (Known as TUF-LOK® in Europe) screws through all bore holes and fit nuts to the screws.

If NYLOK BLUE PATCH™ (Known as TUF-LOK® in Europe) screws are not available we recommend using NORD-LOCK® washers under bolts and nuts. (NYLOK BLUE PATCH is a trademark of Nylok Corporation. TUF-LOK is a registered trademark of Nylok Corporation in Europe. NORD-LOCK is a registered trademark of Nord-Lock International AB.)

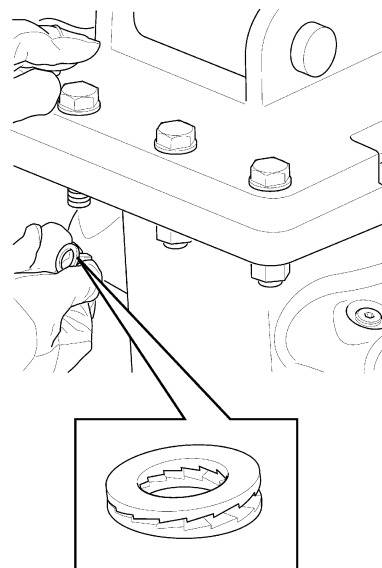

3. Tighten the nuts, see the tightening torque in the table below.

Adapter plate	Tightening torque
SB 52	240 Nm
SB 102	170 Nm
SB 152	170 Nm
SB 202	170 Nm
SB 302	170 Nm
SB 302 SC	170 Nm
SB 452	400 Nm
SB 452 SC	400 Nm
SB 552	400 Nm

Connecting the breaker to the carrier

1. Position the breaker in a safe way during installation.

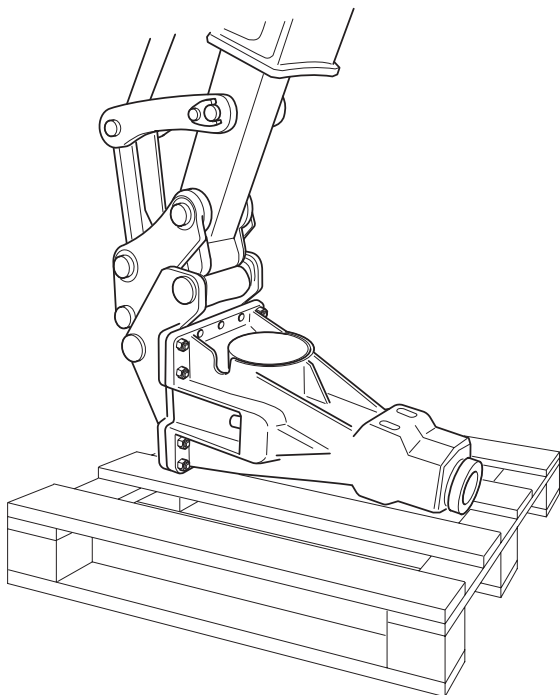

The pressure inlet on the hydraulic breaker is on the left side when you are facing the accumulator. If the pressure hose is on the other side of the boom you can cross the hoses or turn the hydraulic breaker.

2. Carefully lower the stick of the boom into the adapter.

▲ WARNING Moving parts can crush and cut

- Never check bores or passages with hands or fingers.

An assistant must direct the movement of the boom until the bores in the boom are flush with those in the adapter.

Agree with the assistant on clear hand signals for use during the mounting procedure.

3. Insert the pin and lock.

4. Lift up the hydraulic breaker using the boom.
5. Extend the bucket cylinder until the bore in the toggle is flush with those in the adapter. Insert toggle pin and lock.
6. After mounting the breaker, carefully extend and retract the bucket cylinder to its full extent in each direction. It is important that the cylinder can be fully extended and retracted without any difficulty.

Pressure adjustment

The hydraulic breaker is equipped with a pressure relief valve which secures the breaker. The operating pressure of the machine (max 150 bar) is checked and adjusted by a pressure gauge while operating the hydraulic breaker.

- ◆ If the operating pressure is more than 150 bar the pressure must be decreased. Reduce the oil flow from the carrier until the pressure is down to 150 bar. This adjustment is important to ensure that the built in pressure relief valve in the breaker does not open and leak oil back to the tank and create heating problems.
- ◆ If the operating pressure is between 130–150 bar, normally no adjustment is needed.
- ◆ If the carrier's oil flow is too low to retain an acceptable operating pressure the restrictor in the breaker needs to be changed. See flow diagrams in "Technical data" to choose the best restrictor for your application.

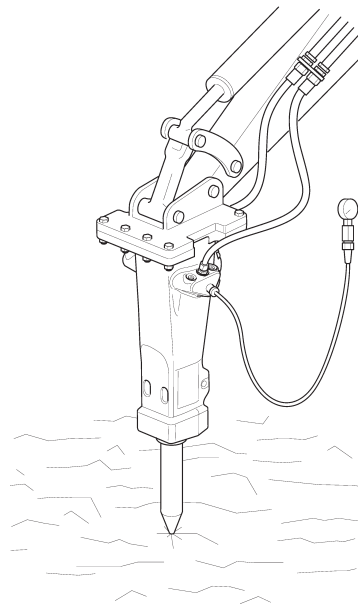

Position the hydraulic breaker vertically towards solid bedrock or similar to adjust the pressure using a pressure gauge.

Water flushing

The hydraulic breaker is prepared for water flushing, this function is to bind the dust when performing demolition operations.

When connecting water flushing the plug in the front of the breaker must be exchanged with a water nozzle. See the Spare parts list for ordering a new water nozzle.

Use a ¼ in. hydraulic hose with a JIC connection as a proper water hose. Contact your nearest authorised workshop for further instructions.

NOTICE It is recommended to use water flushing to reduce the wear on the hydraulic breaker during tunnel and dust-intensive applications.

Working tool

Selecting the right working tool

Conical moil point

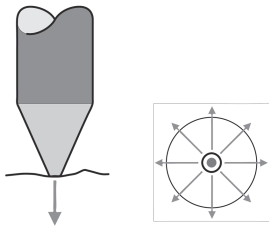

- Very good penetration
- Regular spread of wedge action
- No torsion effect

Chisels and spades

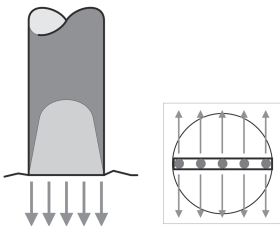

- Very good spread of wedge action
- Good penetration
- Torsion effect

Blunt tool

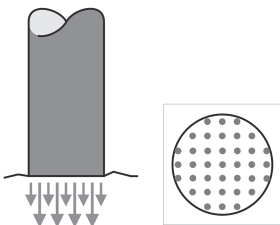

- Very good energy application
- Optimum breaking effect
- No torsion effect

Changing the working tool

▲ WARNING Running engine

Changing the inserted tool or accessories while the carrier's engine is running can cause serious injury.

► Secure the carrier against involuntary activation.

1. Shut the carrier's engine off.
2. Dismount the working tool, use a lifting strap to reduce the risk of personal injury.

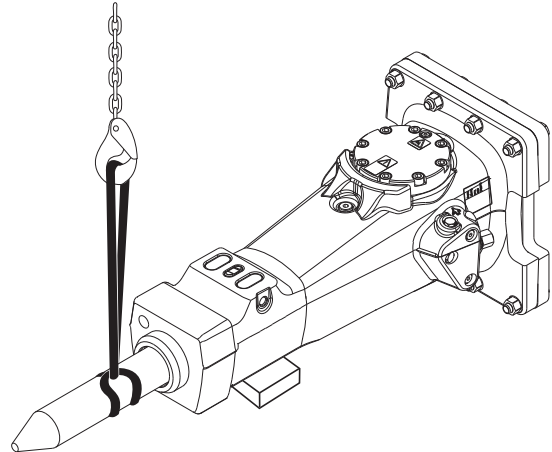

3. Remove and check the lock buffer. Change worn or damaged parts.

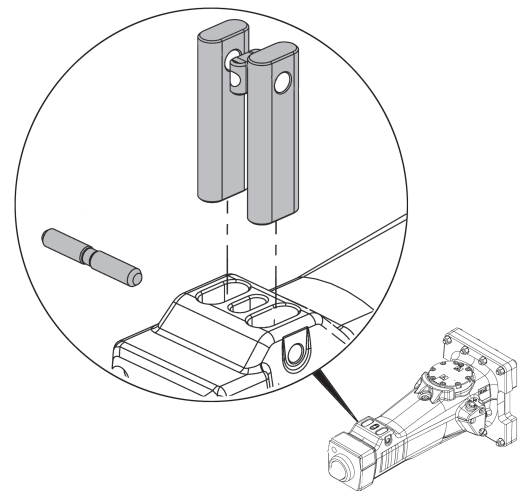

NOTICE The lock buffer in the tool retainer lock is made of plastic and can melt when operating in a hot environment. If this occurs, change the standard lock pin. Find optional spring pin in the spare parts list.

4. Clean and lubricate the bushing plentifully.

NOTICE When mounting a new working tool, it is especially important to lubricate plentifully.

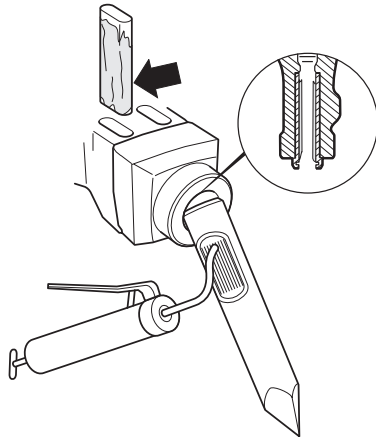

5. Mount the working tool, use a lifting strap to reduce the risk of personal injury
6. Rotate the working tool to spread the grease.
7. Mount the tool retainers, one at the time.
8. Drive in the lock pin until the lock buffer attaches in the lock pin groove.

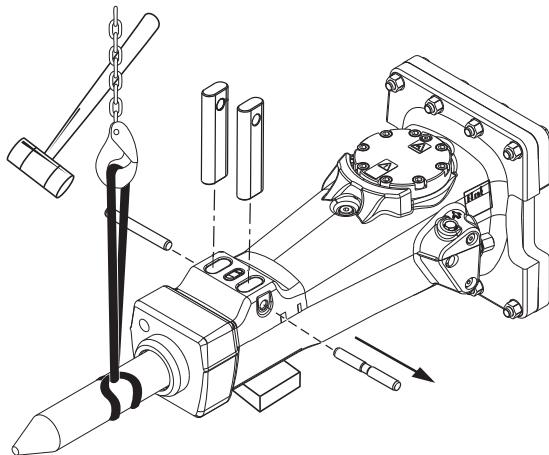

Operation

NOTICE The hydraulic breaker or the working tool is not to be used as a lifting device. When lifting heavy components use the hook on the carrier arm.

Preparation before breaking

Operating temperatures

The operating temperatures of the hydraulic breaker are between -20°C (-4°F) and $+80^{\circ}\text{C}$ ($+176^{\circ}\text{F}$).

⚠ CAUTION Temperature hazard

The hydraulic breaker and the hydraulic oil system of the carrier can be damaged if the hydraulic breaker is used at higher or lower temperatures.

- ▶ Only start the hydraulic breaker when the hydraulic oil has reached the proper operating temperature.
- ▶ If the ambient temperature is below -20°C (-4°F), you must warm up the working tool and the hydraulic breaker before use.
- ▶ If the oil temperature exceeds $+80^{\circ}\text{C}$ ($+176^{\circ}\text{F}$), you must not use the hydraulic breaker as the oil quality becomes inadequate which severely shortens the life time of seals and O-rings.

Engine rpm

Too high engine rpm only results in increased fuel consumption and increased oil temperature. Adapt the engine rpm to the recommended value to give the correct operating oil flow.

Operating

Risk area

Before starting the hydraulic breaker, make sure that no persons are in the risk area, 20 meters both horizontally and vertically from the hydraulic breaker.

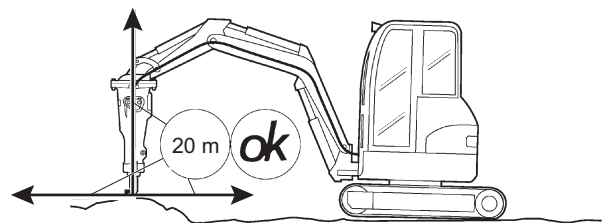

Breaking

⚠ CAUTION Machine and tool hazard

Continuous operation at full extension and/or retraction can result in damage to the hydraulic cylinders.

- ▶ Always avoid operating the breaker with the cylinders fully extended or retracted.
- ▶ Reposition the carrier and/or boom to avoid fully extended or retracted cylinders.
- ▶ Pay attention and look at what you are doing.

Never start the hydraulic breaker until both carrier and the hydraulic breaker are in the correct position.

- ◆ Direct the hydraulic breaker in a position 90° towards the object.

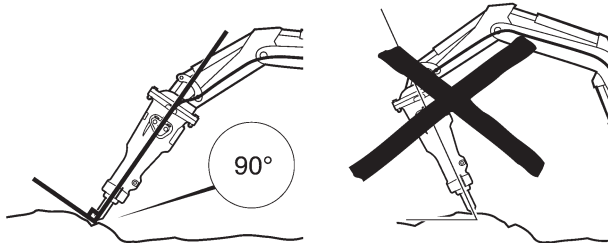
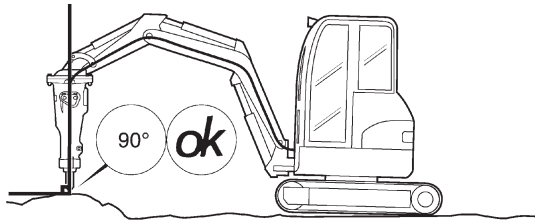

- ◆ Start near the edge and work your way in towards the middle. Never start in the middle of large objects.

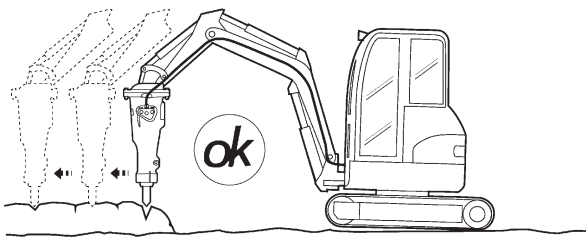

- ◆ Never run the hydraulic breaker longer than 15 seconds on the same spot. Move the working tool to a new position if the object does not break.

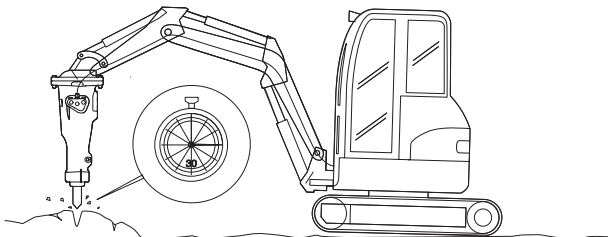

- ◆ Never bend with the working tool.

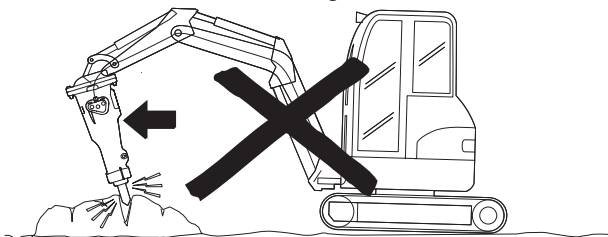

- ◆ Use the correct feed pressure. When the feed pressure is correct the hydraulic breaker is working at its best and the vibrations are at a minimum. Also the wear on the bushing and inserted tool is kept to a minimum.
- ◆ Listen to the sound from the hydraulic breaker. The sound changes if there is any bending between the working tool and bushing.
- ◆ Never run the breaker with the boom cylinders at their end positions. It may cause damage to the carrier.

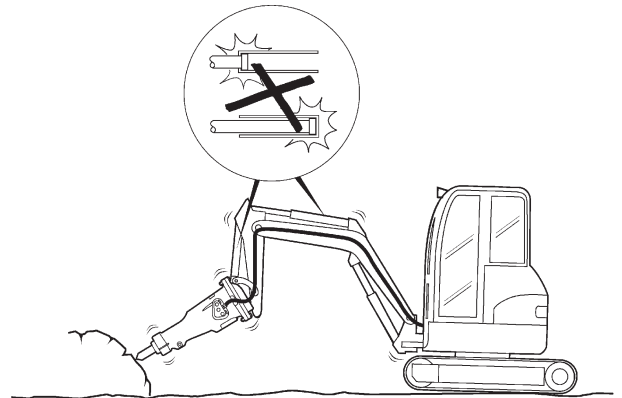
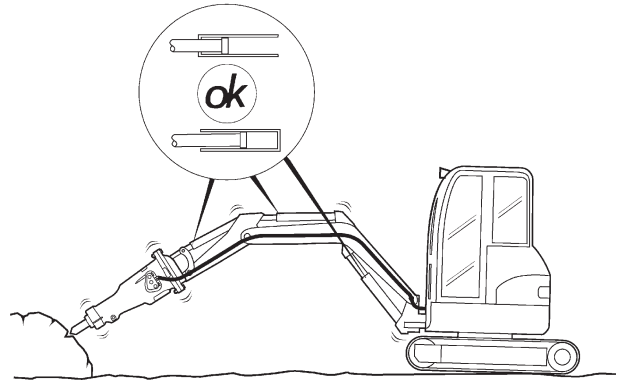

- ◆ Avoid idling strokes; it causes wear on both working tool and tool retainers.

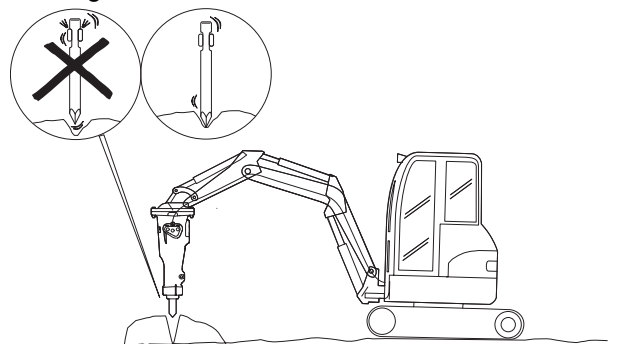

- ◆ The hydraulic breaker or the working tool is not to be used as a lifting device. When lifting heavy components use the hook on the carrier arm.

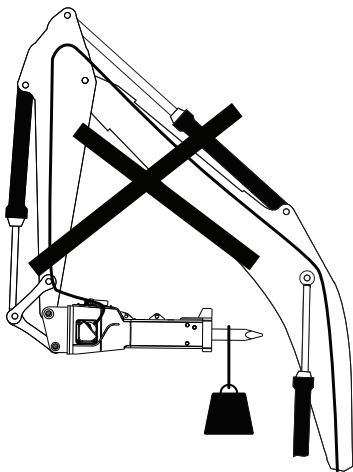

- ◆ Never use the hydraulic breaker as a sledge hammer to demolish material.

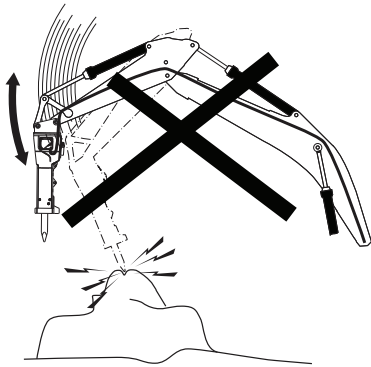

- ◆ Never use the hydraulic breaker to move debris.

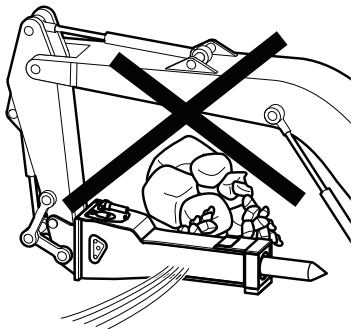

Breaking under water

Hydraulic breakers can be used for operating under water.

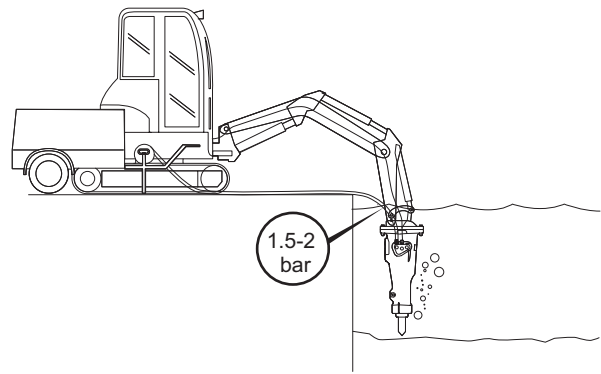

NOTICE When operating under water the hydraulic breaker must be fed with compressed air to keep the area between the piston and the inserted tool free from water. If the area between the piston and the inserted tool gets filled with water, it may penetrate into the hydraulic oil system when the hydraulic breaker is started.

The air pressure must be 1.5-2 bar at the air inlet on the breaker and the air consumption can be found in "Technical data". Suitable air hose is a ¼ in. hydraulic hose with JIC connection. Contact your nearest authorised workshop for further instructions.

Heavy duty operation

The hydraulic breakers SB302 SC and SB452 SC are specially suited for heavy duty operations such as scaling in tunnelling and underground applications. The SC breakers are equipped with water nozzles (A).

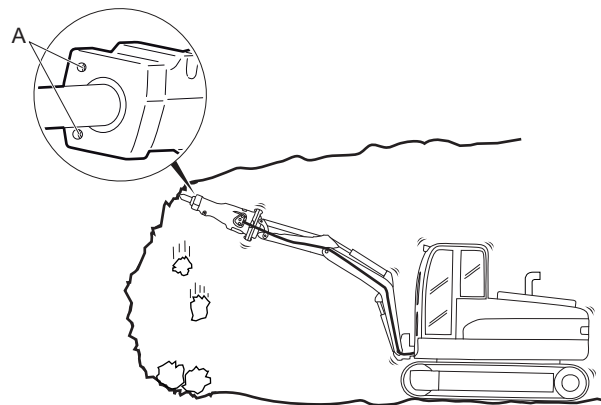

Use a permanent water flushing and air supply as standard to minimize wear and enable dust binding during operation. See "Hoses and connections" for information about connecting utilities.

Other breakers in the SB series, with the exception of SB52 and SB102, can be retrofitted with water nozzles. More information about water nozzles can be found in the Spare parts list.

Special attention should be taken to ensure proper lubrication and maintenance during heavy duty operation. The use of a permanent lubrication system or the ContiLube™ II micro is recommended.

Maintenance

It is essential that regular maintenance is performed to maintain the breakers maximum efficiency.

Equipment that is insufficiently maintained can be dangerous for both the operator and persons near the breaker. Make sure that regular maintenance routines with lubrication are followed to keep the equipment safe and efficient.

Every second hour

Regularly lubricate the working tool, tool retainers and the bushings, with Atlas Copco chisel paste.

Lubricating with a grease gun

▲ **WARNING** Hot insertion tool during operation and a period of time after use.

- ▶ Avoid contact with the insertion tool.

▲ **WARNING** Hot hydraulic breaker during operation and a period of time after use.

- ▶ Avoid contact with the hydraulic breaker.

▲ **CAUTION** Skin eczema

Grease can cause eczema if it comes in contact with the skin.

- ▶ Avoid getting grease on your hands. Wash thoroughly after contact.

1. Press the insertion tool all the way into the breaker up to the stop (A). Otherwise the space between the top of the insertion tool and the piston will be filled with grease, and damage can occur to seals, piston, and cylinder.

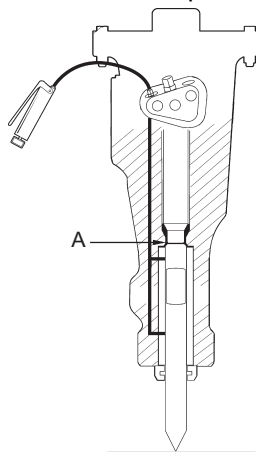

2. Lubricate the insertion tool's shank plentifully during all upward operations. The bushing and the insertion tool must be lubricated so frequently that dirt cannot penetrate into the hydraulic breaker.

When the insertion tool is exposed to high pressure and high temperatures a standard type of grease will melt and run. To avoid this always use Atlas Copco chisel paste.

Central lubrication system

We recommend Atlas Copco's central lubrication system. When this system is fitted on the carrier, grease is pumped continuously from a lubrication container on the carrier to the hydraulic breaker when the hydraulic breaker is activated. This increases the life of the tool bushings and working tools considerably.

Every day

- ◆ Check tool retainers and lock pins for damage, change if necessary.
- ◆ Check that hoses, couplings, and accumulator are in a good condition, change if necessary.
- ◆ Check that bolts and connections are free from damage and properly tightened, change if damaged. See tightening torques in the spare parts list.
- ◆ Refill the central lubricating system.
- ◆ Check that wear plate and bolts are free from damage, change if necessary.

Every week

- ◆ Clean the hydraulic breaker carefully.
- ◆ Check the wear bushing's wear and maximum inner wear limits.

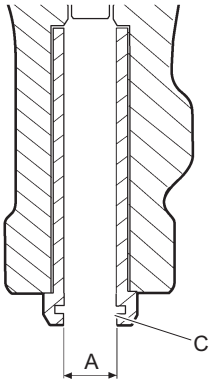

The wear bushing must be replaced when the inner diameter (A) has reached its maximum wear limit, see section "Wear limits" and "Replacing the insertion tool bushing".

- ◆ Check the working tool for wear.
The working tool must be replaced when the outer diameter (B) has reached its minimum wear limit. See section "Wear limits".



Too large clearance can make the working tool break and the piston can be damaged.

- ◆ Check the scraper ring (C) for wear and function, replace if necessary.
- ◆ Check the breaker and the adapter plate for cracks and wear.
- ◆ Check that the accumulator screws are properly tightened. The correct tightening torque is found in the spare parts list.

The working tool may never be sharpened by forging. Sharpening must only be performed by milling, grinding, or turning.

Wear limits

	A mm (in.)	B mm (in.)
SB 52	42 (1.6)	38 (1.5)
SB 102	47 (1.8)	43 (1.7)
SB 152	52 (2.0)	48 (1.9)
SB 202	68 (2.7)	63 (2.5)
SB 302	83 (3.3)	78 (3.1)
SB 302 SC	83 (3.3)	78 (3.1)
SB 452	98 (3.85)	92 (3.6)
SB 452 SC	98 (3.85)	92 (3.6)
SB 552	103 (4.1)	97 (3.8)

Replacing the insertion tool bushing

The insertion tool bushing is kept in place by the tool retainers. A new bushing has a slip fit.

1. Remove scraper ring and bushing. If a worn out bushing is stuck, use a sliding hammer to remove it.

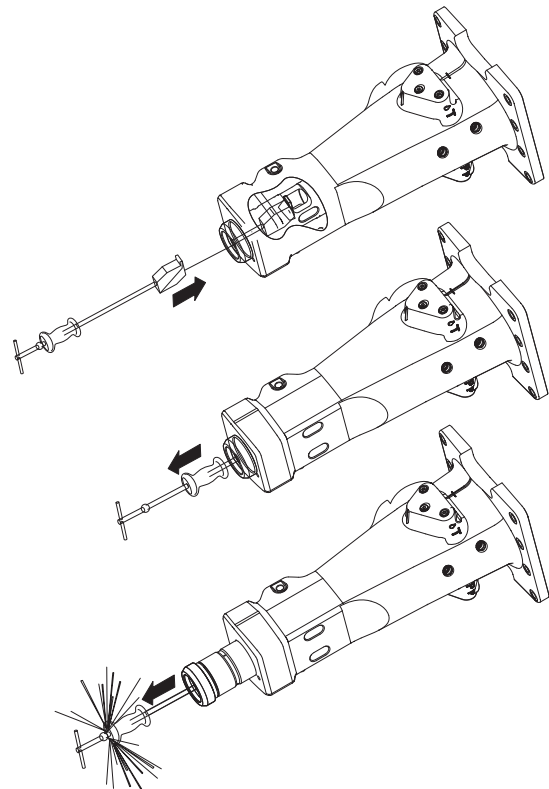

2. Carefully clean the bore and the bushing seat area.
3. Mount new O-rings, lubricate and mount the bushing.
4. Use a plastic sledgehammer to insert the bushing.
5. Rotate the bushings until the tool retainers find their position at the bushing.
6. Mount a new scraper ring.

Every year

Overhauling must be done after one year of continuous operation. Overhauling must for safety reasons be performed by authorised personnel at an authorised workshop.

Storage

▲ WARNING Hydraulic breaker and working tool are heavy

If the breaker or working tool topple over or fall down it can result in material damage and personal injury.

- ▶ Store the hydraulic breaker and the working tool so that falling or rolling down is prevented.

If the hydraulic breaker is not used for a long time, the following steps have to be considered to protect the hydraulic breaker from corrosion:

1. Clean the hydraulic breaker carefully.
2. Dismount the working tool and lubricate the front part of the piston, bushing and the tool retainer lock.
3. Store the hydraulic breaker in a dry place.

Disposal

A used machine must be treated and scrapped in such a way that the greatest possible portion of the material can be recycled and any negative influence on the environment is kept as low as possible.

Before a used machine is scrapped it must be emptied and cleaned from all hydraulic oil. The remaining hydraulic oil must be deposited and any negative influence on the environment is to be kept as low as possible.

Troubleshooting

Hydraulic breaker does not start

Cause	Remedy	By
Pressure and tank hoses are mixed up.	Check that the connections of the pressure and tank hoses are correct. See section "Hoses and connection".	Carrier driver
Shut off valve in pressure and/or tank hoses is closed.	Check the shut off valve and open it.	Carrier driver
Defective couplings blocking pressure and tank hoses.	Check couplings and replace defective coupling valves.	Workshop
Operating pressure too low.	Check the carrier engine speed, the pump delivery and the pressure relief valve. Check the operating pressure. Adjust settings and replace defective parts if required. See section "Installation".	Carrier driver or Atlas Copco Customer Center/Dealer in your area
Return pressure too high.	Check and lower the return pressure.	Atlas Copco Customer Center/Dealer in your area

Impact force too low

Cause	Remedy	By
Gas pressure too low, whipping and pulsing hoses.	Check the gas pressure and fill the high pressure accumulator. Check the condition of the accumulator, replace if necessary.	Workshop
Hydraulic oil pressure too low.	Check the pressure, adjust as required. Fit new pressure relief cartridges on carrier and breaker, if necessary. Check the installation, check the restrictor, and check the carrier's pressure. See section "Pressure adjustment".	Workshop

Oil leaks

Cause	Remedy	By
Leaking or damaged seals.	Replace the seals.	Workshop

Hydraulic breaker operates too slowly

Cause	Remedy	By
Insufficient hydraulic oil delivery volume.	Check the engine speed and/or mode stage of the carrier and the operation pressure and adjust. Check the carrier's pressure and the size of the restrictor.	Carrier driver
Valve in pressure and/or tank hoses partly closed.	Check the valve and open.	Carrier driver
Flow resistance on oil filter or oil cooler too high.	Check the oil filter and oil cooler, clean or replace them.	Carrier driver
Working tool jams in the lower breaker part.	Correct the direction of the carrier boom. The pressing force must act in the axial direction of the hydraulic breaker. Check the shaft of the working tool and deburr if required. Use the right type, and amount of grease. Always use Atlas Copco chisel paste. Check the working tool and the wear bush for wear and replace if necessary. See section "Working tool".	Carrier driver
Inside diameter of tank hose too small.	Check the inside diameter and change if necessary. Observe the minimum inside diameter! See section "Hoses and connections".	Workshop
Return pressure too high.	Check and lower the return pressure.	Atlas Copco Customer Center/Dealer in your area
Hydraulic oil temperature in the tank higher than 80°C (176°F).	Check the oil level in the hydraulic tank and top up if necessary. Check the oil flow. Too high oil flow leads to a higher working pressure and temperature, and that the oil flows over the pressure limiter. Check the cooler function on the carrier. See section "Preparation before breaking".	Carrier driver
Hydraulic oil pressure too low.	Check the pressure, adjust as required. Fit new pressure relief cartridges if necessary, on carrier and breaker. Check the installation, check the restrictor, and check the carrier's pressure. See section "Pressure adjustment".	Workshop

Operating temperature too high

Cause	Remedy	By
Oil level in tank too low.	Check the oil level and top up oil.	Carrier driver or workshop
Carrier's pump delivery too high, a constant volume of oil is squirted out of the pressure relief valve.	Check carrier engine speed and lower.	Carrier driver
	Check carrier settings and adjust.	Atlas Copco Customer Center/Dealer in your area
Operation in high outside temperature without oil cooler.	Check oil temperature and install an oil cooler if necessary.	Workshop or Atlas Copco Customer Center/Dealer in your area
Pressure relief valve defective or valve with poor characteristic.	Fit new pressure relief cartridges.	Workshop

Technical data

Machine data

	SB 52	SB 102	SB 152	SB 202	SB 302	SB 302 SC	SB 452	SB 452 SC	SB 552
Part number	8460 0300 10	8460 0300 30	8460 0300 40	8460 0300 50	8460 0300 60	8460 0300 62	8460 0300 70	8460 0300 72	8460 0300 80
Service weight, kg (lb)	55 (120)	90 (190)	140 (310)	200 (440)	300 (670)	304 (670)	440 (970)	441 (972)	520 (1150)
Delivery weight kg (lb)	44 (97)	68 (150)	110 (243)	155 (392)	224 (494)	224 (494)	321 (708)	321 (708)	390 (860)
Suitable carrier weight class, tonnes (lbs)	0.7–1.1 (1,550-2,400)	1.1–3.0 (2,400-6,600)	1.9–4.5 (4,200-9,900)	2.5–6.0 (5,500-13,250)	4.5-9.0 (9,900-19,840)	4.5-9 (9,900-19,840)	6.5-13 (14,300-28,650)	6.5-13 (14,300-28,650)	9.0-15 (19,840-33,100)
Working length of working tool in standard version, mm (in.)	255 (10.00)	250 (9.85)	250 (9.85)	300 (11.8)	440 (17.20)	440 (17.32)	470 (18.40)	470 (18.50)	475 (18.70)
Working tool diameter, mm (in.)	40 (1.57)	45 (1.77)	50 (1.97)	65 (2.56)	80 (3.15)	80 (3.15)	95 (3.74)	95 (3.74)	100 (3.94)
Start up mode	AutoStart	AutoStart	AutoStart	AutoStart	AutoStart	AutoStart	AutoStart	AutoStart	AutoStart
Hose inside diameter P, mm (in.)	10 ($\frac{3}{8}$)	12 ($\frac{1}{2}$)	12 ($\frac{1}{2}$)	12 ($\frac{1}{2}$)	19 ($\frac{3}{4}$)	19 ($\frac{3}{4}$)	19 ($\frac{3}{4}$)	19 ($\frac{3}{4}$)	25 (1)
Hose inside diameter T, mm (in.)	10 ($\frac{3}{8}$)	12 ($\frac{1}{2}$)	12 ($\frac{1}{2}$)	12 ($\frac{1}{2}$)	19 ($\frac{3}{4}$)	19 ($\frac{3}{4}$)	19 ($\frac{3}{4}$)	19 ($\frac{3}{4}$)	25 (1)

Capacities

	SB 52	SB 102	SB 152	SB 202	SB 302	SB 302 SC	SB 452	SB 452 SC	SB 552
Oil flow, l/min (gpm)	12–27 (3.0-7.0)	16–35 (4.0-9.0)	25–45 (6.5-12.0)	35–65 (9.0-17.5)	50–80 (13.0-21.0)	50–80 (13.0-21.0)	55-100 (14.5-26.5)	70-100 (18.5-26.5)	65–115 (17.0-30.0)
Impact rate, bpm	750–1,700	750–2,300	850–1,900	850–1,800	600-1,400	950-1,250	550-1,250	850-1,150	650–1,150
Operating pressure, bar (psi)	100–150 (1,450-2,175)	100–150 (1,450-2,175)	100–150 (1,450-2,175)	100–150 (1,450-2,175)	100–150 (1,450-2,175)	100–110 (1,450-1,595)	100–150 (1,450-2,175)	100-110 (1,450-1,595)	100–150 (1,450-2,175)
Maximum hydraulic input power, kW	7	9	11	17	20	15	25	19	29
Back pressure acceptance, bar (psi)	25 (360)	18 (260)	25 (360)	25 (360)	26 (360)	26 (377)	21 (305)	21 (305)	18 (260)
Accumulator gas pressure, bar (psi)	40 (580)	40 (580)	40 (580)	40 (580)	40 (580)	40 (580)	40 (580)	40 (580)	40 (580)
Pressure relief valve on breaker, bar (psi)	180 (2,611)	180 (2,611)	180 (2,611)	170 (2,466)	185 (2,683)	185 (2,683)	185 (2,683)	185 (2,683)	185 (2,683)
Water pressure, bar (psi)	-	-	4 (58)	4 (58)	4 (58)	4 (58)	4 (58)	4 (58)	4 (58)
Water consumption, l/min (gpm)	-	-	≤5 (≤1.3)	≤5 (≤1.3)	≤9 (≤2.4)	≤9 (≤2.4)	≤9 (≤2.4)	≤9 (≤2.4)	≤9 (≤2.4)
Air pressure, bar (psi)	2 (29)	2 (29)	2 (29)	2 (29)	2 (29)	2 (29)	2 (29)	2 (29)	2 (29)
Air flow, m ³ /min (ft ³ /min)	≤0.73 (≤26)	≤0.73 (≤26)	≤0.73 (≤26)	≤0.73 (≤26)	≤0.73 (≤26)	≤0.73 (≤26)	≤0.73 (≤26)	≤0.73 (≤26)	≤0.73 (≤26)

Noise declaration statement

	SB 52	SB 102	SB 152	SB 202	SB 302	SB 302 SC	SB 452	SB 452 SC	SB 552
Sound pressure ¹ dB(A)	89	87	85	90	91	89	94	94	97
Sound power ² dB(A)	117	115	114	118	119	118	122	122	126

¹ Sound pressure level according to EN ISO 3744 in accordance with directive 2000/14/EC at 10 metres distance.

² Guaranteed sound power according to EN ISO 3744 in accordance with directive 2000/14/EC inclusive spread in production.

These declared values were obtained by laboratory type testing in accordance with the stated directive or standards and are suitable for comparison with the declared values of other tools tested in accordance with the same directive or standards. These declared values are not adequate for use in risk assessments and values measured in individual work places may be higher. The actual exposure values and risk of harm experienced by an individual user are unique and depend upon the way the user works, in what material the breaker is used, as well as upon the exposure time and the physical condition of the user, and the condition of the breaker.

We, Construction Tools PC AB, cannot be held liable for the consequences of using the declared values, instead of values reflecting the actual exposure, in an individual risk assessment in a work place situation over which we have no control.

Flow diagrams for the correct operating pressure

The carrier's oil flow can be restricted to achieve the right operating pressure. Restrictors can be ordered from the spare parts list. The diagrams show oil flow at viscosity 32 cSt.

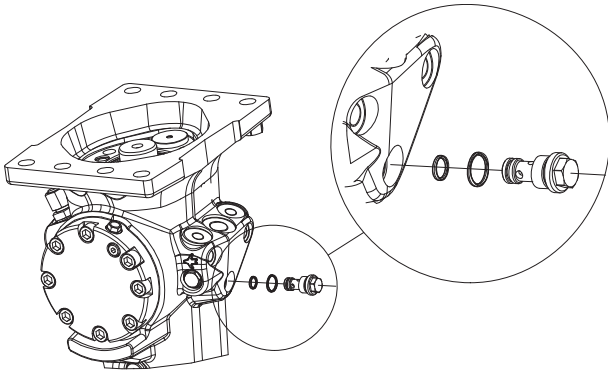

SB 52: 100–150 bar

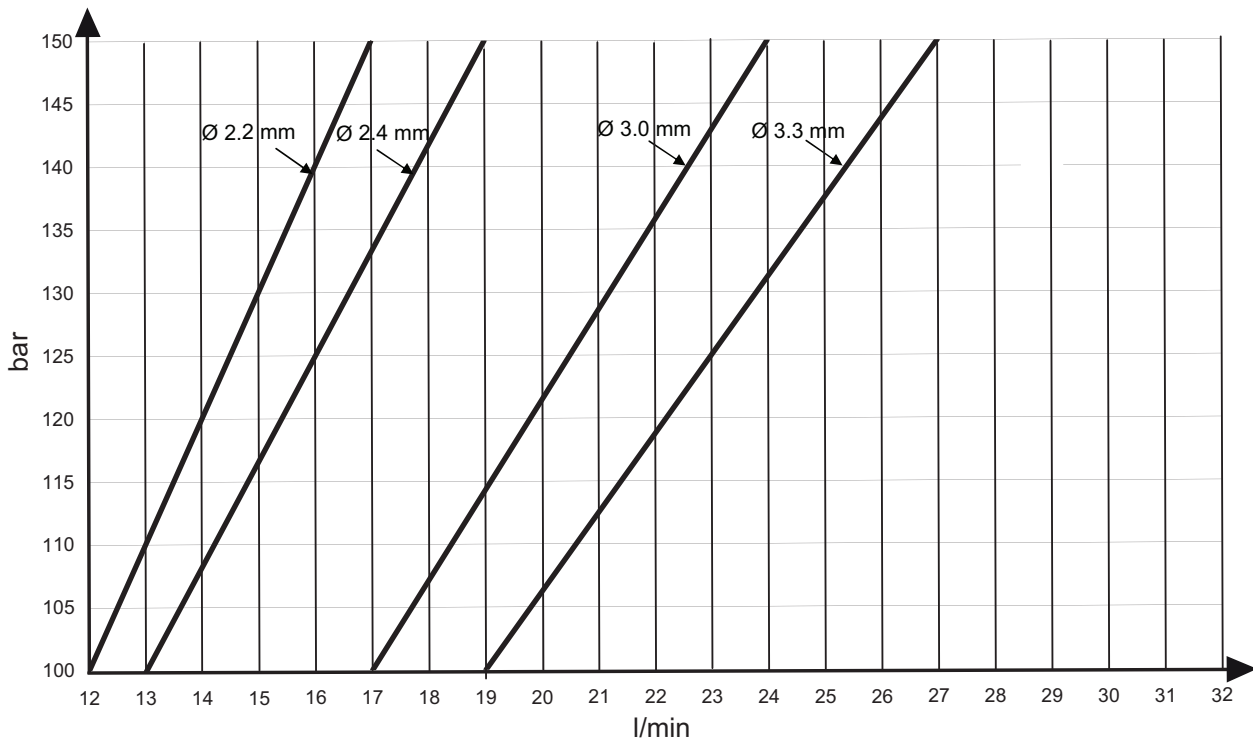

SB 102: 100–150 bar

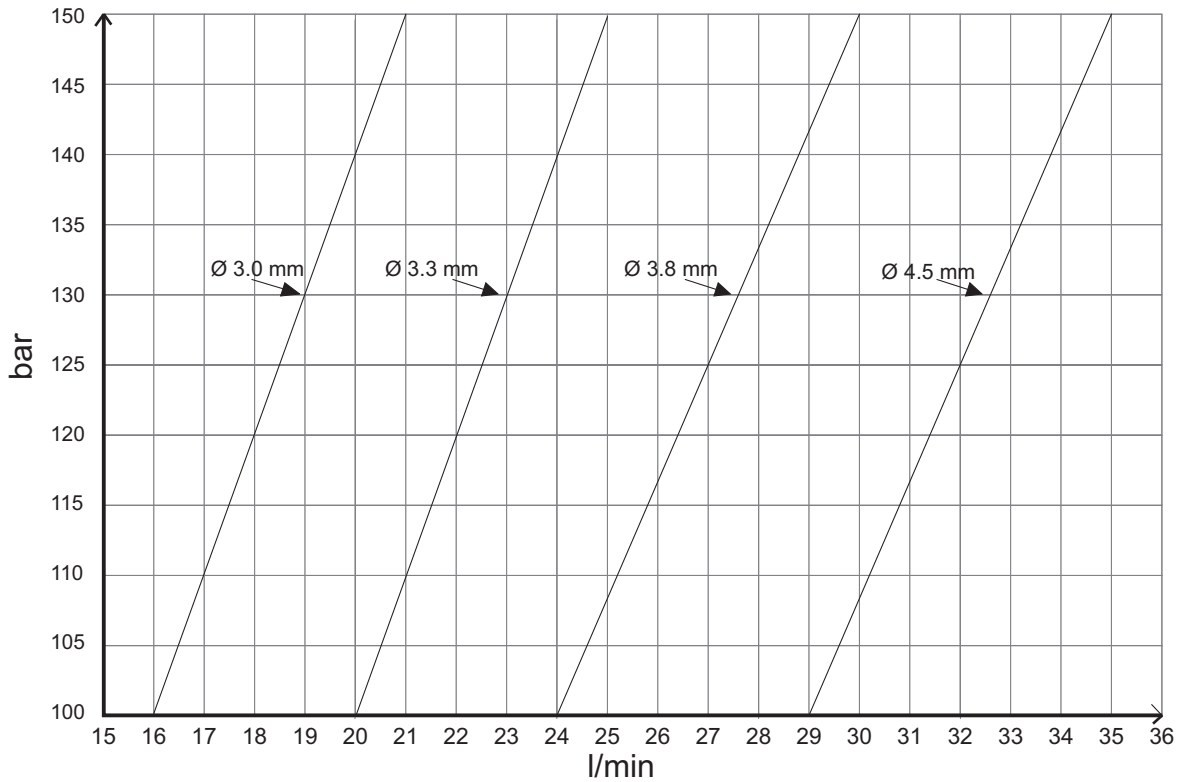

SB 152: 100–150 bar

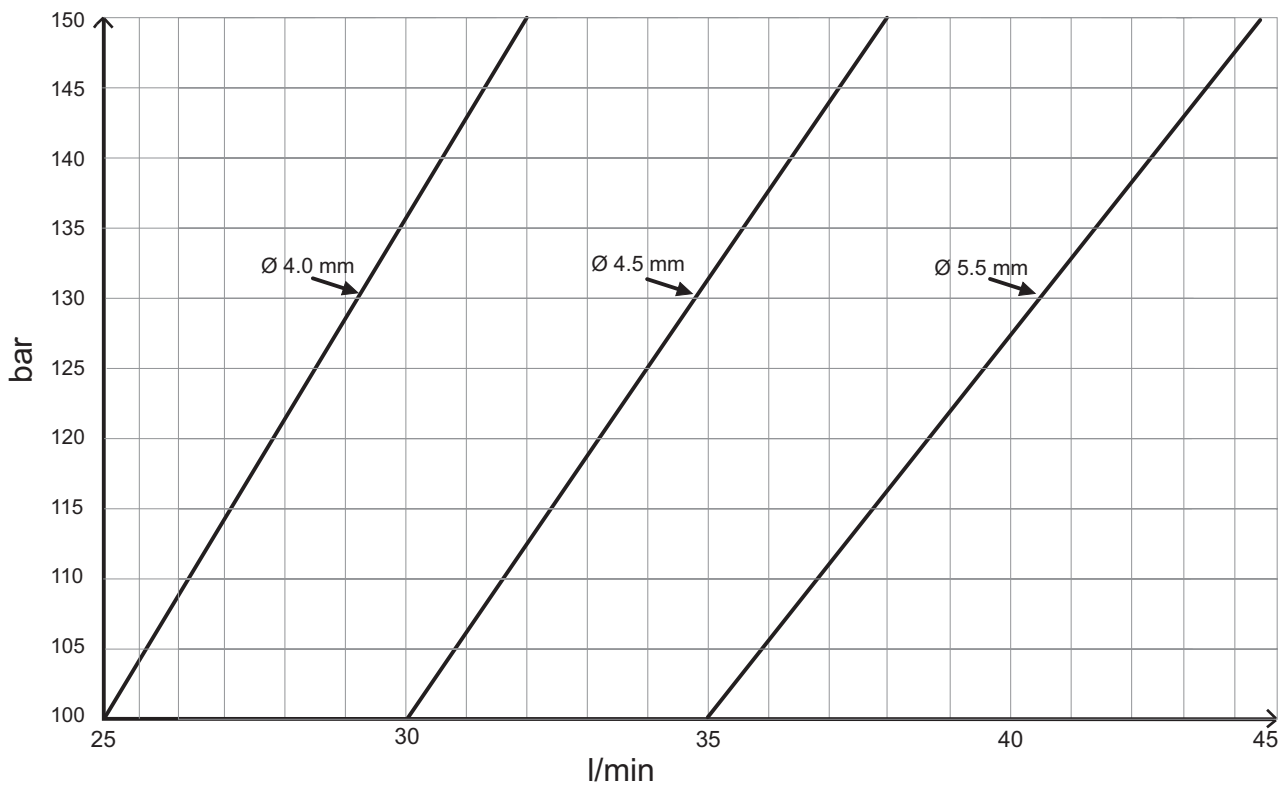

SB 202: 100–150 bar

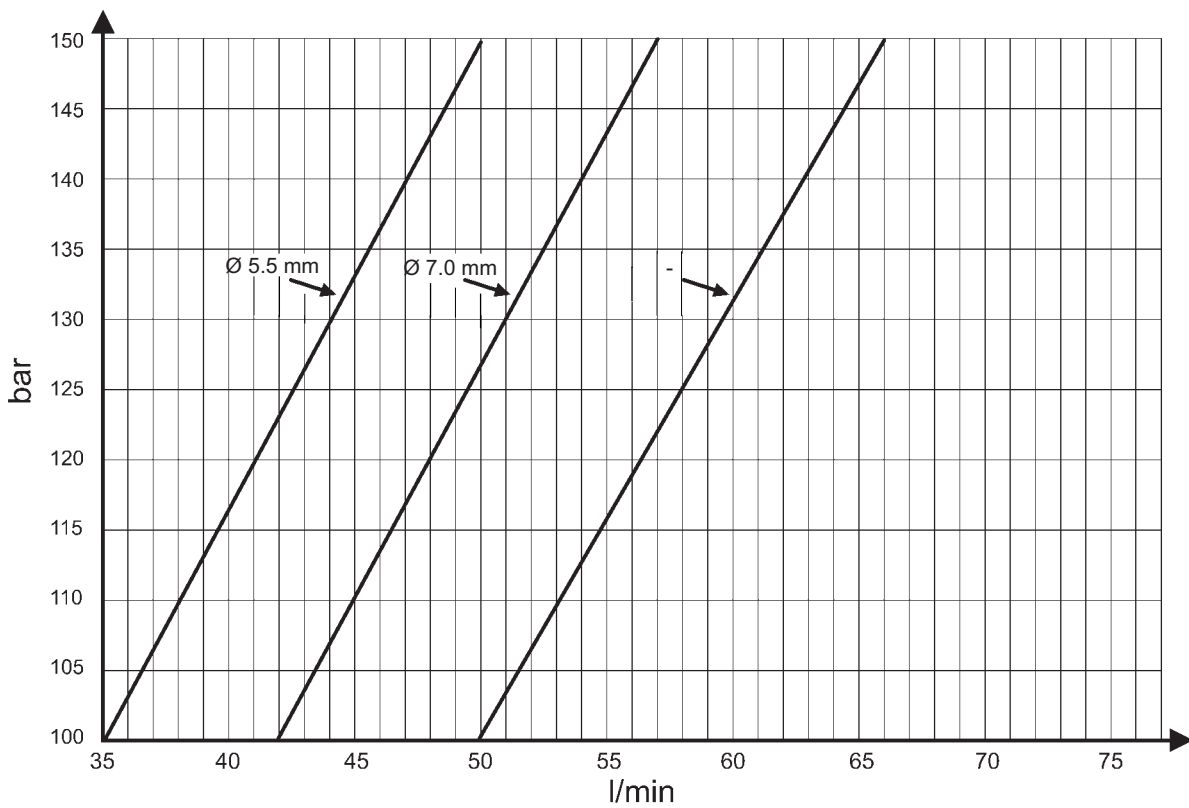

SB 302: 100-150 bar

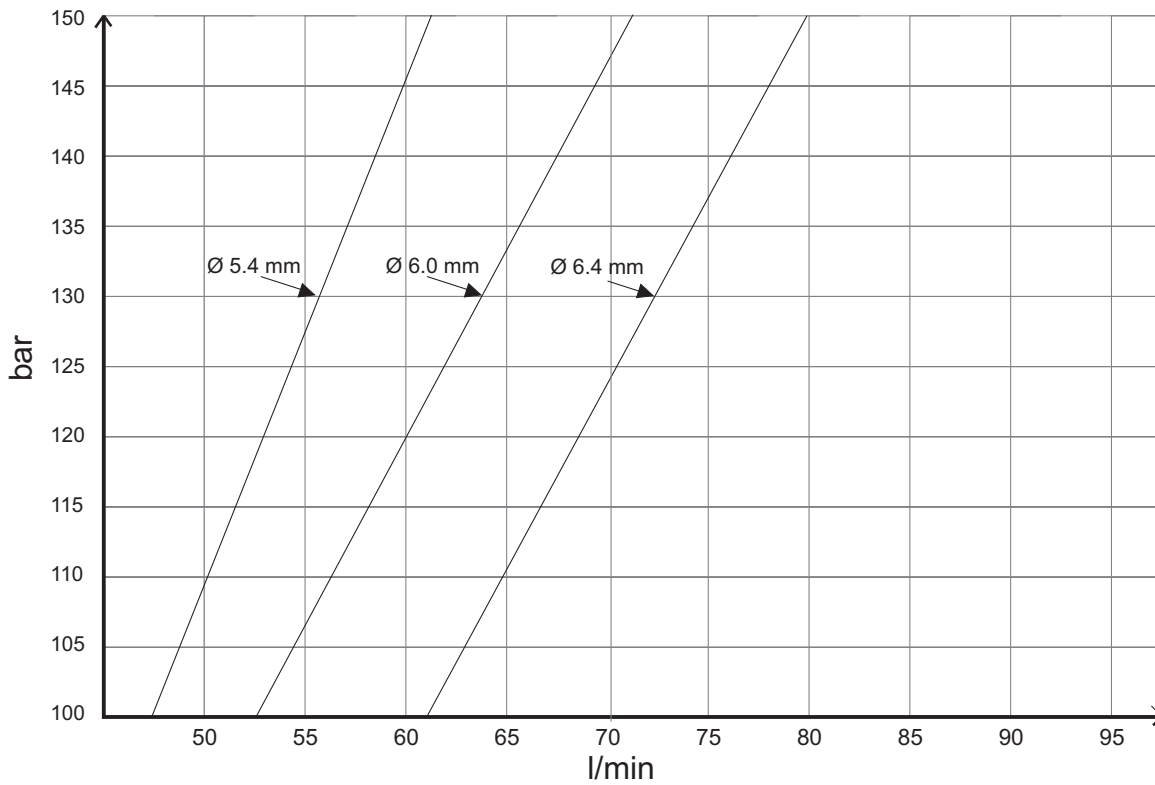

SB 452: 100–150 bar

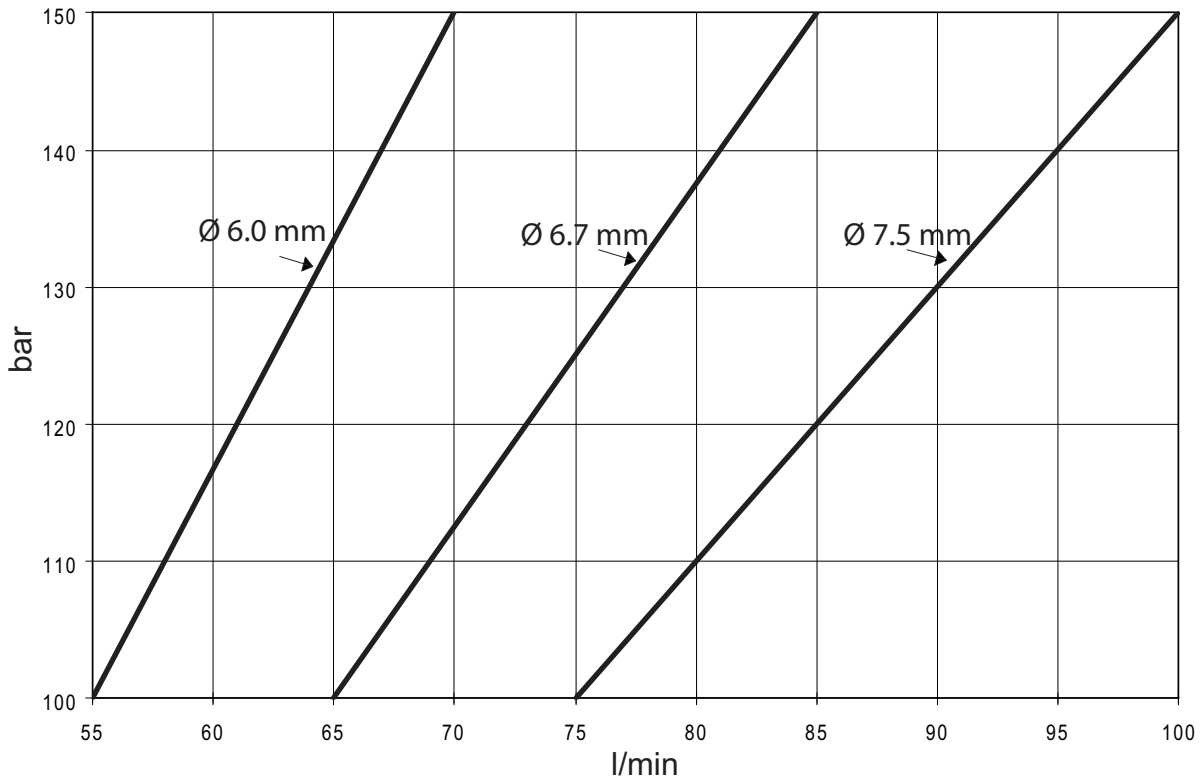

SB 552: 100–150 bar

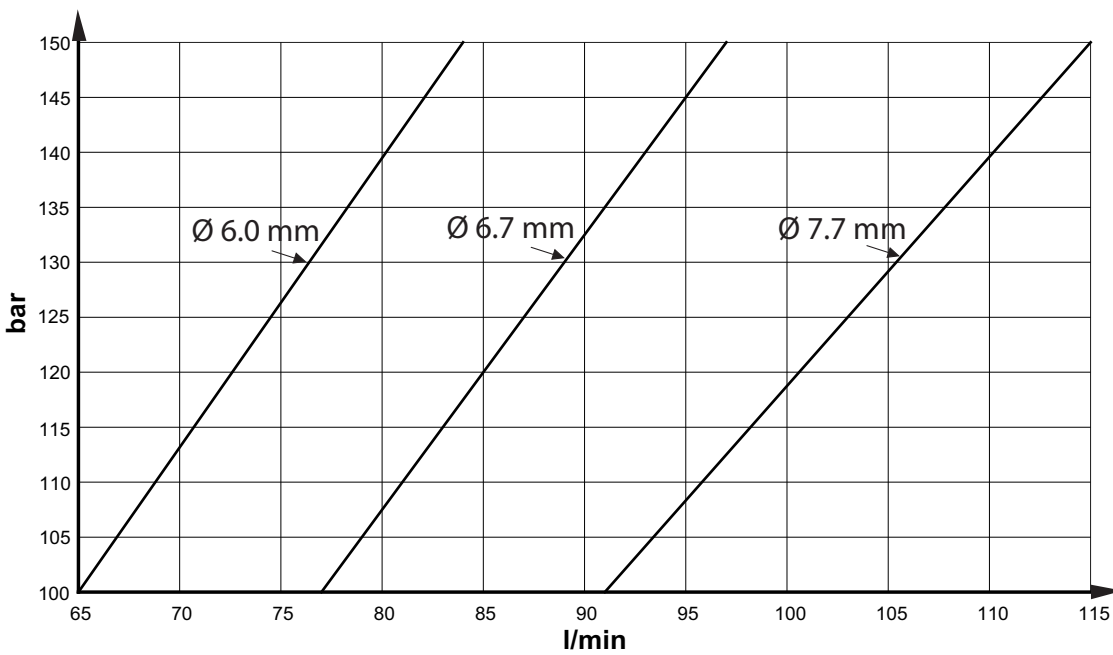

EC Declaration of Conformity

EC Declaration of Conformity (EC Directive 2006/42/EC)

We, Construction Tools PC AB, hereby declare that the machines listed below conform to the provisions of EC Directive 2006/42/EC (Machinery Directive) and 2000/14/EC (Noise Directive).

Hydraulic breaker	Guaranteed sound power level [dB(A)]	Measured sound power level [dB(A)]	Pmax (bar)	Weight (kg)
SB 52	117	116	150	44
SB 102	115	115	150	68
SB 152	114	113	150	110
SB 202	118	118	150	155
SB 302	120	119	150	224
SB 302 SC	118	117	110	224
SB 452	122	121	150	321
SB 452 SC	122	121	110	321
SB 552	126	125	150	390

Technical Documentation authorised representative:

Conny Sjöbäck
 Construction Tools PC AB
 Dragonvägen 2
 Kalmar

General Manager:

Jenny Hassan

Manufacturer:

Construction Tools PC AB
 Box 703
 391 27 Kalmar
 Sweden

Place and date:

Kalmar, 2012-03-01

Any unauthorized use or copying of the contents or any part thereof is prohibited.
This applies in particular to trademarks, model denominations, part numbers, and
drawings.

© 2014 Construction Tools PC AB | No. 9800 0648 01 | 2014-06-11

Atlas Copco

www.atlascopco.com