



Operation & Safety Manual

*Original Instructions -
Keep this manual with the machine at all times.*

***Model
RT2669, RT3369,
ERT2669, ERT3369***

PVC 2204

31220312

October 10, 2022 - Rev C

ANSI CE UK CA 
AS/NZS GB

JLG
An Oshkosh Corporation Company

WARNING

Operating, servicing and maintaining this vehicle or equipment can expose you to chemicals including engine exhaust, carbon monoxide, phthalates, and lead, which are known to the State of California to cause cancer and birth defects or other reproductive harm. To minimize exposure, avoid breathing exhaust, do not idle the engine except as necessary, service your vehicle or equipment in a well-ventilated area and wear gloves or wash your hands frequently when servicing. For more information go to www.P65Warnings.ca.gov.

FOREWORD

The Mobile Elevating Work Platform (MEWP) models covered in this manual are designed and tested to meet or exceed various compliance standards. Please refer to the manufacturer's nameplate affixed to the subject MEWP for specific standard compliance information.

This manual is a very important tool! Keep it with the machine at all times.

The purpose of this manual is to provide owners, users, operators, lessors, and lessees with the precautions and operating procedures essential for the safe and proper machine operation for its intended purpose.

Due to continuous product improvements, JLG Industries, Inc. reserves the right to make specification changes without prior notification. Contact JLG Industries, Inc. for updated information.

Refer to www.JLG.com for Warranty, Product Registration, and other machine-related documentation.

SAFETY ALERT SYMBOLS AND SAFETY SIGNAL WORDS



This is the Safety Alert Symbol. It is used to alert you to the potential personal injury hazards. Obey all safety messages that follow this symbol to avoid possible injury or death.

⚠ DANGER

Indicates an imminently hazardous situation. If not avoided, will result in serious injury or death. This decal will have a red background.

⚠ WARNING

Indicates a potentially hazardous situation. If not avoided, could result in serious injury or death. This decal will have an orange background.

⚠ CAUTION

Indicates a potentially hazardous situation. If not avoided, may result in minor or moderate injury. It may also alert against unsafe practices. This decal will have a yellow background.

NOTICE

Indicates information or a company policy that relates directly or indirectly to the safety of personnel or protection of property.

⚠ WARNING

This product must comply with all safety related bulletins. Contact JLG Industries, Inc. or the local authorized JLG representative for information regarding safety related bulletins which may have been issued for this product.

NOTICE

JLG Industries, Inc. sends safety related bulletins to the owner of record of this machine. Contact JLG Industries, Inc. to ensure that the current owner records are updated and accurate.

NOTICE

JLG Industries, Inc. must be notified immediately in all instances where JLG products have been involved in an accident involving bodily injury or death or when substantial damage has occurred to personal property or the JLG product.

Foreword

For:

- Accident Reporting
- Product Safety Publications
- Current Owner Updates
- Questions Regarding Product Safety
- Standards and Regulations Compliance Information
- Questions Regarding Special Product Applications
- Questions Regarding Product Modifications

Contact:

Product Safety and Reliability Department

JLG Industries, Inc.

13224 Fountainhead Plaza

Hagerstown, MD 21742

USA

or Visit www.jlg.com to find your local JLG office.

In USA:

Toll Free: 877-JLG-SAFE (877-554-7233)

Outside USA:

Phone: 240-420-2661

Fax: 301-745-3713

E-mail: ProductSafety@JLG.com

REVISION LOG

DATE	REVISION	DESCRIPTION
April 11, 2022	A	Original Issue
July 19, 2022	B	Revision
October 10, 2022	C	Revision

This Page is intentionally left blank

SECTION CONTENTS

Section	Subject	Page
FOREWORD		3
REVISION LOG		7
SECTION 1		
SAFETY PRECAUTIONS		13
1.1	General.....	13
1.2	Pre-Operation.....	13
1.3	Operation	15
1.4	Towing, Lifting, and Hauling	21
1.5	Maintenance	22
SECTION 2		
USER RESPONSIBILITIES, MACHINE PREPARATION, AND INSPECTION		26
2.1	Personnel Training	26
2.2	Preparation, Inspection, and Maintenance	27
2.3	Pre-Start Inspection	28
2.4	Walk-Around Inspection.....	31
2.5	Function Check.....	33
2.6	Oscillating Axle - Lockout Cylinder Test (If Equipped) (CE/ UKCA Markets Only)	34
2.7	Oscillating Axle — Lockout Cylinder Test (If Equipped) (All Markets Except CE/UKCA).....	36
2.8	QuikLevel Advanced Test (If Equipped)	37
SECTION 3		
MACHINE CONTROLS, INDICATORS, AND OPERATION		39
3.1	General.....	39
3.2	Description	39
3.3	Operating Characteristics and Limitations.....	40
3.4	Platform Loading	40
3.5	Battery Charging (ERT Machines).....	41
3.6	Ground Control Station.....	44

Section Contents

3.7	Ground Control Station Display Gauge.....	46
3.8	Platform Control Station	48
3.9	Indicator Display.....	51
3.10	Navigating the Indicator Display	56
3.11	Engine Operation.....	58
3.12	Dual Fuel System (If Equipped).....	60
3.13	Traveling (Driving).....	60
3.14	Traveling (Grade/Side Slope).....	61
3.15	Platform	62
3.16	Leveling Jacks (If Equipped).....	63
3.17	QuikLevel Advanced (Dual Oscillating Axles) (If Equipped).....	65
3.18	Parking and Stowing	66
3.19	Platform Rails Fold-Down Procedure.....	66
3.20	Machine Lifting and Tie Down	70
3.21	Towing.....	71
3.22	Lifting and Tie Down Chart.....	71
3.23	RT2669, RT3369 Decal Locations.....	71
3.24	Safety Decal Legend.....	73
3.25	ERT2669, ERT3369 Decal Locations	77

SECTION 4

EMERGENCY PROCEDURES 84

4.1	General.....	84
4.2	Incident Notification.....	84
4.3	Emergency Operation.....	84
4.4	Platform Manual Descent Control.....	85
4.5	Emergency Towing Procedures	86

SECTION 5

ACCESSORIES..... 90

5.1	Available Accessories.....	90
5.2	Footswitch	91
5.3	Generator (2500W).....	92
5.4	Onboard Generator (3500W).....	93
5.5	Panel Carrier.....	94
5.6	Pipe Racks.....	96
5.7	Platform Extension Handle	97
5.8	Platform Worklights.....	98

5.9	Workstation.....	98
-----	------------------	----

SECTION 6

MACHINE SPECIFICATIONS AND OPERATOR

MAINTENANCE 102

6.1	General.....	102
6.2	Other Publications Available.....	102
6.3	Machine Specifications	102
6.4	Engine Specifications.....	107
6.5	Engine Oil Operating Temperature	108
6.6	Lubrication.....	110
6.7	Scissor Arm Safety Prop	114
6.8	Battery Maintenance and Charging.....	115
6.9	Battery Disconnect (ERT Machines)	117
6.10	Operator Maintenance.....	118
6.11	ERT Genset (If Equipped).....	123
6.12	Propane Fuel System	127
6.13	Tires and Wheels.....	127
6.14	Supplemental Information Only Applicable to CE/UKCA Machines	129
6.15	EC Declaration of Conformity.....	130
6.16	UKCA Declaration of Conformity	131

This Page is intentionally left blank

SECTION 1

Safety Precautions

1.1 GENERAL

This section outlines the necessary precautions for proper and safe machine usage and maintenance. It is mandatory that a daily routine is established based on the content of this manual to promote proper machine usage. A maintenance program, using the information provided in this manual and the Service & Maintenance Manual, must also be established by a qualified person and must be followed to ensure that the machine is safe to operate.

The owner/user/operator/lessor/lessee of the machine must not accept operating responsibility until this manual has been read, training is accomplished, and operation of the machine has been completed under the supervision of an experienced and qualified operator.

This section contains the responsibilities of the owner, user, operator, lessor, and lessee concerning safety, training, inspection, maintenance, application, and operation. If there are any questions with regard to safety, training, inspection, maintenance, application, and operation, please contact JLG Industries, Inc. ("JLG").

⚠ WARNING

Failure to comply with the safety precautions listed in this manual could result in machine damage, property damage, personal injury or death.

1.2 PRE-OPERATION

1.2.1 Operator Training and Knowledge

- Read, understand, and study the Operation & Safety Manual in its entirety before operating the machine. For clarification, questions, or additional information regarding any portions of this manual, contact JLG Industries, Inc.

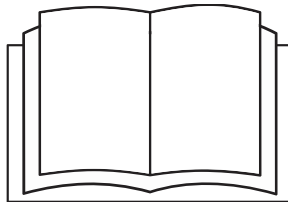

- Only personnel who have received proper training regarding the inspection, application and operation of MEWPs (including recognizing and avoiding hazards associated with their operation) shall be authorized to operate a MEWP.

Safety Precautions

- Only properly trained personnel who have received unit-specific familiarization shall operate a MEWP. The user shall determine if personnel are qualified to operate the MEWP prior to operation.
- Read, understand, and obey all DANGERS, WARNINGS, CAUTIONS, and operating instructions on the machine and in this manual.
- Ensure that the machine is to be used in a manner which is within the scope of its intended application as determined by JLG.
- All operating personnel must have a thorough understanding of the intended purpose and function of the MEWP controls, including platform, ground and emergency descent controls.
- Read, understand, and obey all applicable employer, local, and governmental regulations as they pertain to your utilization and application of the machine.

1.2.2 Workplace Inspection

- Precautions to avoid all hazards in the work area must be taken by the user before and during operation of the machine.
- Do not operate or raise the platform from a position on trucks, trailers, railway cars, floating vessels, scaffolds or other equipment unless the application is approved in writing by JLG.
- Before operation, check work area for overhead hazards such as electric lines, bridge cranes, and other potential overhead obstructions.
- Check operating surfaces for holes, bumps, drop-offs, obstructions, debris, concealed holes, and other potential hazards.
- Check the work area for hazardous locations. Do not operate the machine in hazardous environments unless approved for that purpose by JLG.
- Ensure that the ground conditions are adequate to support the maximum tire load indicated on the tire load decals located on the chassis adjacent to each wheel. Do not travel on unsupported surfaces.
- This machine can be operated in nominal ambient temperatures of 0° F to 104° F (-20° C to 40° C). Consult JLG to optimize operation outside of this temperature range.

1.2.3 Machine Inspection

- Do not operate this machine until the inspections and functional checks as specified in the User Responsibilities, Machine Preparation, and Inspection Section of this manual have been performed.
- Do not operate this machine until it has been serviced and maintained according to the maintenance and inspection requirements as specified in the machine's Service & Maintenance Manual.
- Ensure all safety devices are operating properly. Modification of these devices is a safety violation.

WARNING

Modification or alteration of a MEWP shall be made only with prior written permission from the manufacturer.

- Do not operate any machine on which the safety or instruction placards or decals are missing or illegible.
- Check the machine for modifications to original components. Ensure that any modifications have been approved by JLG.
- Avoid accumulation of debris on platform floor. Keep mud, oil, grease, and other slippery substances from footwear and platform floor.

1.3 OPERATION

1.3.1 General

- Machine operation requires your full attention. Bring the machine to a full stop before using any device, i.e. cell phones, two-way radios, etc. that will distract your attention from safely operating the machine.
- Do not use the machine for any purpose other than positioning personnel, their tools, and equipment.
- Before operation, the user must be familiar with the machine capabilities and operating characteristics of all functions.
- Never operate a malfunctioning machine. If a malfunction occurs, shut down the machine. Remove the unit from service and notify the proper authorities.
- Do not remove, modify, or disable any safety devices.
- Never slam a control switch or lever through neutral to an opposite direction. Always return switch to neutral and stop before moving the switch to the next function. Operate controls with slow and even pressure.
- Do not allow personnel to tamper with or operate the machine from the ground with personnel in the platform, except in an emergency.
- Do not carry materials directly on platform railing unless approved by JLG.
- When two or more persons are in the platform, the operator shall be responsible for all machine operations.
- Always ensure that power tools are properly stowed and never left hanging by their cord from the platform work area.
- Do not assist a stuck or disabled machine by pushing or pulling except by pulling at the chassis tie-down lugs.
- Fully lower platform and shut off all power before leaving machine.

Safety Precautions

- Remove all rings, watches, and jewelry when operating machine. Do not wear loose fitting clothing or long hair unrestrained which may become caught or entangled in equipment.
- Persons under the influence of drugs or alcohol or who are subject to seizures, dizziness or loss of physical control must not operate this machine.
- Hydraulic cylinders are subject to thermal expansion and contraction. This may result in changes to the platform position while the machine is stationary. Factors affecting thermal movement can include the length of time the machine will remain stationary, hydraulic oil temperature, ambient air temperature, and platform position.

1.3.2 Trip and Fall Hazards

- Prior to operation, ensure all gates and rails are fastened and secured in their proper position.

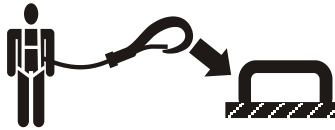

- JLG Industries, Inc. recommends that all persons in the platform wear a full body harness with a lanyard attached to an authorized lanyard anchorage point while operating this machine. For further information regarding fall protection requirements on JLG products, contact JLG Industries, Inc.
- Identify the designated lanyard anchorage point (s) at the platform and securely attach the lanyard. Attach only one (1) lanyard per lanyard anchorage point.
- Enter and exit only through gate area. Use extreme caution when entering or leaving platform. Ensure that the platform assembly is fully lowered. Face the machine when entering or leaving the platform. Always maintain “three point contact” with the machine, using two hands and one foot or two feet and one hand at all times during entry and exit.

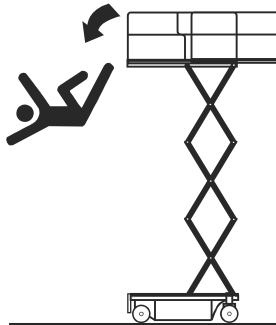

- Keep both feet firmly positioned on the platform floor at all times. Never position ladders, boxes, steps, planks, or similar items on unit to provide additional reach for any purpose.

- Never use the scissor arm assembly to gain access to or leave the platform.
- Keep oil, mud, and slippery substances cleaned from footwear and the platform floor.

1.3.3 Electrocution Hazards

- This machine is not insulated and does not provide protection from contact with or proximity to electrical current.
- It is not recommended to use the machine during lightning. To prevent injury or machine damage if lightning occurs during operation, lower the boom and shut down the machine in a safe and secure location.

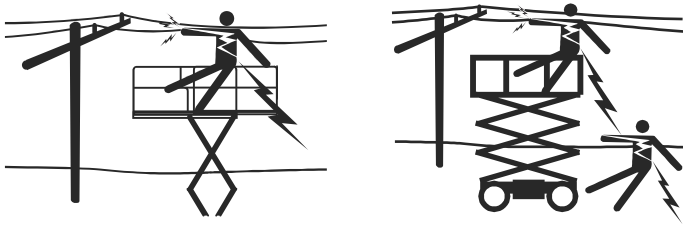

- Maintain distance from electrical lines, apparatus, or any energized (exposed or insulated) parts according to the Minimum Approach Distance (MAD) as shown in [Table — Minimum Approach Distances \(MAD\), page 17](#).
- Allow for machine movement and electrical line swaying.

Table 1. Minimum Approach Distances (MAD)

Voltage Range (Phase to Phase)	Minimum Approach Distance in Feet (Meters)
0 to 50 KV	10 (3)
Over 50K V to 200 KV	15 (5)
Over 200 KV to 350 KV	20 (6)
Over 350 KV to 500 KV	25 (8)
Over 500 KV to 750 KV	35 (11)
Over 750 KV to 1000 KV	45 (14)
<p>Note: This requirement shall apply except where employer, local or governmental regulations are more stringent.</p>	

- Maintain a clearance of at least 10 ft (3m) between any part of the machine and its occupants, their tools, and their equipment from any electrical line or apparatus carrying up to 50,000 volts. One foot additional clearance is required for every additional 30,000 volts or less.

Safety Precautions

- The MAD may be reduced if insulating barriers are installed to prevent contact, and the barriers are rated for the voltage of the line being guarded. These barriers shall not be part of (or attached to) the machine.
- The MAD shall be reduced to a distance within the designed working dimensions of the insulating barrier. This determination shall be made by a qualified person with respect to electrical transmission and distribution in accordance with the employer, local, or governmental requirements for work practices near energized equipment.

⚠ DANGER

Do not maneuver machine or personnel inside prohibited zone (MAD). Assume all electrical parts and wiring are energized unless known otherwise.

1.3.4 Tipping Hazards

- Ensure that the ground conditions are adequate to support the maximum tire load indicated on the tire load decals located on the chassis adjacent to each wheel. Do not travel on unsupported surfaces.
- The user must be familiar with the operating surface before driving. Do not exceed the allowable side slope and grade while driving.

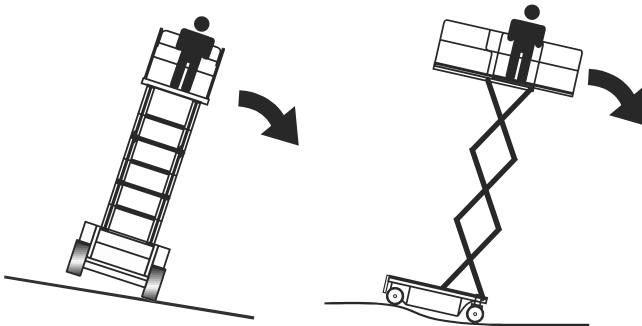

- Do not elevate platform or drive with platform elevated while on or near a sloping, uneven, or soft surface.
- Ensure machine is positioned on a smooth, firm surface within the limits of the maximum operating slope before elevating platform or driving with the platform in the elevated position.
- Before driving on floors, bridges, trucks, and other surfaces, check allowable capacity of the surfaces.
- Never exceed the maximum platform capacity as specified on the platform. Keep all loads within the confines of the platform, unless authorized by JLG.
- Keep the chassis of the machine a minimum of 2 ft (0.6m) from holes, bumps, drop-offs, obstructions, debris, concealed holes, and other potential hazards at the ground level.

- Do not push or pull any object with the machine.
- Never attempt to use the machine as a crane. Do not tie-off machine to any adjacent structure. Never attach wire, cable, or any similar items to platform.
- If the scissor arm assembly or platform is caught so that one or more wheels are off the ground, all persons must be removed before attempting to free the machine. Use cranes, forklift trucks, or other appropriate equipment to stabilize machine.
- Do not operate the machine when wind conditions, including gusts, exceed specifications shown in the Machine Specifications and Operator Maintenance section. Refer to *Table — Beaufort Scale (For Reference Only), page 20*. Factors affecting wind speed are; platform elevation, surrounding structures, local weather events, and approaching storms.
- Wind speed can be significantly greater at height than at ground level.
- Wind speed can change rapidly. Always consider approaching weather events, the time required to lower the platform, and methods to monitor current and potential wind conditions.
- Do not cover or increase surface area of the platform or the load. Do not carry large surface area items in the platform when operating outdoors. The addition of such items increases the exposed wind area of the machine. Increased areas exposed to wind will decrease stability.
- Do not increase the platform size with unauthorized modifications, deck extensions, or attachments.

WARNING

Do not operate the machine when wind conditions exceed specifications shown in the General Specifications section of this manual or as shown on the capacity placard on the platform billboard.

Table 2. Beaufort Scale (For Reference Only)

Beaufort Number	Wind Speed		Description	Land Conditions
	mph	m/s		
0	0	0-0.2	Calm	Calm. Smoke rises vertically
1	1-3	0.3-1.5	Light air	Wind motion visible in smoke
2	4-7	1.6-3.3	Light breeze	Wind felt on exposed skin. Leaves rustle
3	8-12	3.4-5.4	Gentle breeze	Leaves and smaller twigs in constant motion
4	13-18	5.5-7.9	Moderate breeze	Dust and loose paper raised. Small branches begin to move.
5	19-24	8.0-10.7	Fresh breeze	Smaller trees sway.
6	25-31	10.8-13.8	Strong breeze	Large branches in motion. Flags waving near horizontal. Umbrella use becomes difficult.
7	32-38	13.9-17.1	Near Gale/Moderate Gale	Whole trees in motion. Effort needed to walk against the wind.
8	39-46	17.2-20.7	Fresh Gale	Twigs broken from trees. Cars veer on road.
9	47-54	20.8-24.4	Strong Gale	Light structure damage.

1.3.5 Crushing and Collision Hazards

- Approved head gear must be worn by all operating and ground personnel.
- Watch for obstructions around machine and overhead when driving. Check clearances above, on sides, and bottom of platform during all operations.

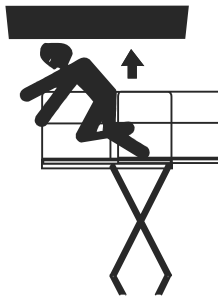

- During operation, keep all body parts inside platform railing.
- Keep hands and limbs out of the scissor arm assembly during operation and when elevated without safety prop engaged.
- Always post a lookout when driving in areas where vision is obstructed.

- Keep non-operating personnel at least 6 ft (1.8 m) away from machine during all operations.
- Under all travel conditions, the operator must limit travel speed according to conditions of ground surface, congestion, visibility, slope, location of personnel, and other factors.
- Be aware of stopping distances in all drive speeds. When driving in high speed, reduce drive speed before stopping. Travel grades in low speed only.
- Do not use high speed drive in restricted or close quarters or when driving in reverse.
- Exercise extreme caution at all times to prevent obstacles from striking or interfering with operating controls and persons in the platform.
- Ensure that operators of other overhead and floor level machines are aware of the MEWP's presence. Disconnect power to overhead cranes. Barricade floor area if necessary.
- Do not operate over ground personnel. Warn personnel not to work, stand, or walk under a raised boom or platform. Position barricades on floor if necessary.

WARNING

If driving machine with the platform control station from ground, do not hang the control box on any part of the machine while driving. Hold the control box and keep at least 3 ft (1 m) distance from machine.

1.4 TOWING, LIFTING, AND HAULING

- Never allow personnel in platform while towing, lifting, or hauling.
- This machine should not be towed, except in the event of emergency, malfunction, power failure, or loading/unloading. Refer to the Emergency Procedures section of this manual for emergency towing procedures.
- Ensure platform is fully retracted and completely empty of tools prior to towing, lifting or hauling.
- When lifting machine with a forklift, position forks only at designated areas of the machine. Lift with a forklift of adequate capacity.
- Refer to the Machine Operation section of this manual for lifting information.

1.5 MAINTENANCE

This sub-section contains general safety precautions which must be observed during maintenance of this machine. Additional precautions to be observed during machine maintenance are inserted at the appropriate points in this manual and in the Service and Maintenance Manual. It is of utmost importance that maintenance personnel pay strict attention to these precautions to avoid possible injury to personnel or damage to the machine or property. A maintenance program must be established by a qualified person and must be followed to ensure that the machine is safe.

1.5.1 Maintenance Hazards

- Shut off power to all controls and ensure that all moving parts are secured from inadvertent motion prior to performing any adjustments or repairs.
- Never work under an elevated platform until it has been fully lowered to the full down position, if possible, or otherwise supported and restrained from movement with appropriate safety props, blocking, or overhead supports.
- DO NOT attempt to repair or tighten any hydraulic hoses or fittings while the machine is powered on or when the hydraulic system is under pressure.
- Always relieve hydraulic pressure from all hydraulic circuits before loosening or removing hydraulic components.
- DO NOT use your hand to check for leaks. Use a piece of cardboard or paper to search for leaks. Wear gloves to help protect hands from spraying fluid.



- Use only replacement parts or components that are approved by JLG. To be considered approved, replacement parts or components must be identical or equivalent to original parts or components.
- Never attempt to move heavy parts without the aid of a mechanical device. Do not allow heavy objects to rest in an unstable position. Ensure adequate support is provided when raising components of the machine.
- Use only approved non-flammable cleaning solvents.
- Do not replace items critical to stability, such as batteries or solid tires, with items of different weight or specification. Do not modify the MEWP in any way to affect stability.
- Refer to the Service & Maintenance Manual for the weights of critical stability items.

⚠ WARNING

Modification or alteration of a MEWP shall be made only with prior written permission from the manufacturer.

1.5.2 Battery Hazards

- Always disconnect batteries when servicing electrical components or when performing welding on the machine.
- Do not allow smoking, open flame, or sparks near battery during charging or servicing.
- Do not contact tools or other metal objects across the battery terminals.
- Always wear hand, eye, and face protection when servicing batteries. Ensure that battery acid does not come in contact with skin or clothing.

CAUTION

Battery fluid is highly corrosive. Avoid contact with skin and clothing at all times. Immediately rinse any contacted area with clean water and seek medical attention.

- Charge batteries only in a well ventilated area.
- Avoid overfilling the battery fluid level. Add distilled water to batteries only after the batteries are fully charged.

This Page is intentionally left blank

This Page is intentionally left blank

SECTION 2

User Responsibilities, Machine Preparation, and Inspection

2.1 PERSONNEL TRAINING

The Mobile Elevating Work Platform (MEWP) is a personnel handling device, so it is necessary that it be operated and maintained only by trained personnel.

2.1.1 Operator Training

Operator training must cover:

1. Reading and understanding the Operation and Safety Manual.
2. Thorough understanding of the intended purpose and function of the MEWP controls, including platform, ground, and emergency descent controls.
3. Control labels, instructions, and warnings on the machine.
4. Applicable regulations, standards, and safety rules.
5. Use of approved fall protection equipment.
6. Enough knowledge of the mechanical operation of the machine to recognize a malfunction or potential malfunction.
7. The safest means to operate the machine where overhead obstructions, other moving equipment, and obstacles, depressions, holes, and drop-offs exist.
8. Means to avoid the hazards of unprotected electrical conductors.
9. Selection of the appropriate MEWP and available options for the work to be performed considering specific job requirements, with involvement from the MEWP owner, user, and/ or supervisor.
10. The responsibility of the operator to ensure all platform occupants have a basic level of knowledge to work safely on the MEWP, and to inform them of applicable regulations, standards, and safety rules.
11. The requirement for familiarization in addition to training.

2.1.2 Training Supervision

Training must be delivered by a qualified person in an open area free of hazards until the trainee has demonstrated the ability to safely control and operate the machine.

2.1.3 Operator Responsibility

The operator must be instructed that they have the responsibility and authority to shut down the machine in case of a malfunction or other unsafe condition of either the machine or the job site.

2.1.4 Machine Familiarization

Note: Responsibilities for familiarization may vary by region.

Only properly trained personnel who have received unit-specific familiarization shall operate a MEWP. The user shall determine if personnel are qualified to operate the MEWP prior to operation. The user shall ensure that after familiarization, the operator operates the MEWP for a sufficient period of time to achieve proficiency. When authorized by the user, self-familiarization can be achieved, if authorized, by a properly trained operator reading, understanding and following the manufacturer's operator's manual.

Prior to user's authorization of an operator to use a specific model of MEWP, the user shall ensure the operator is familiarized on the following:

1. Location of the manual storage compartment and the requirement to ensure the required manual(s) are present on the MEWP;
2. Purpose and function of the machine controls and indicators at the platform and ground control stations;
3. Purpose, location, and function of the emergency controls;
4. Operating characteristics and limitations;
5. Features and devices;
6. Accessories and optional equipment.

2.2 PREPARATION, INSPECTION, AND MAINTENANCE

The following table covers machine inspections and maintenance required by JLG Industries, Inc. Consult local regulations for further requirements for MEWPs. The frequency of inspections and maintenance must be increased as necessary when the machine is used in a harsh or hostile environment, if the machine is used with increased frequency, or if the machine is used in a severe manner.

Table 3. Inspection and Maintenance Table

Type	Frequency	Primary Responsibility	Service Qualification	Reference
Pre-Start Inspection	Before using each day; or whenever there is an Operator change	User or Operator	User or Operator	Operation & Safety Manual
Pre-Delivery Inspection (See Note)	Before each sale, lease, or rental delivery	Owner, Dealer, or User	Qualified JLG Mechanic	Service & Maintenance Manual and applicable JLG inspection form
Frequent Inspection (See Note)	In service for 3 months or 150 hours, whichever comes first or Out of service for a period of more than 3 months or Purchased used	Owner, Dealer, or User	Qualified JLG Mechanic	Service & Maintenance Manual and applicable JLG inspection form
Annual Machine Inspection (See Note)	Annually, no later than 13 months from the date of prior inspection	Owner, Dealer, or User	Factory Trained Service Technician (Recommended)	Service & Maintenance Manual and applicable JLG inspection form
Preventive Maintenance	At intervals as specified in the Service & Maintenance Manual	Owner, Dealer, or User	Qualified JLG Mechanic	Service & Maintenance Manual

Note: Inspection forms are available from JLG. Use the Service & Maintenance Manual to perform inspections.

NOTICE

JLG Industries, Inc. recognizes a factory trained service technician as a person who has successfully completed the JLG Service Training School for the specified JLG product model.

2.3 PRE-START INSPECTION

The Pre-Start Inspection should include each of the following:

1. **Cleanliness** – Check all surfaces for leakage (oil, fuel, or battery fluid) or foreign objects. Report any leakage to the proper maintenance personnel.

2. **Structure** – Inspect the machine structure for dents, damage, weld or parent metal cracks or other discrepancies.
Report this to the proper maintenance personnel.

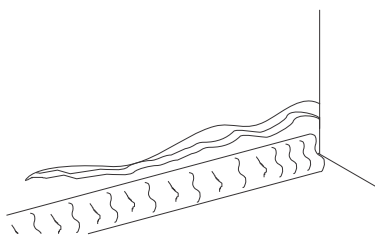

Figure 1. Parent Metal Crack

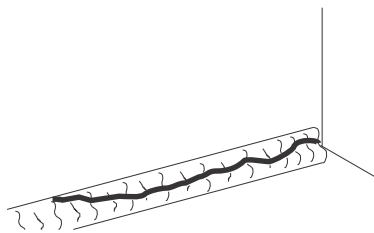
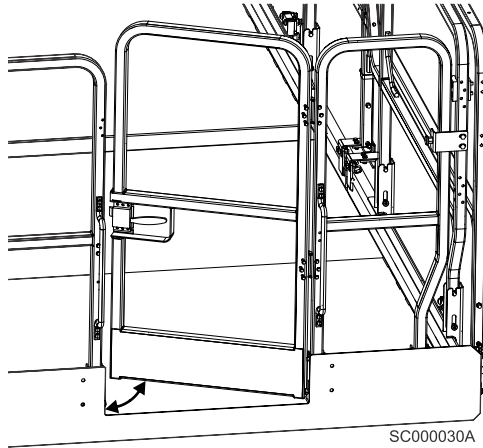

Figure 2. Weld Crack

3. **Decals and Placards** – Check all for cleanliness and legibility. Ensure none of the decals and placards are missing. Ensure all illegible decals and placards are cleaned or replaced (refer to [Section – Decal Installation](#)).
4. **Operation & Safety Manuals** – Ensure that a copy of the Operation & Safety Manual, AEM Safety Manual (ANSI markets only), and ANSI Manual of Responsibilities (ANSI markets only) is enclosed in the weather resistant storage container.
5. **Walk-Around Inspection** – Perform as instructed in [Section – Walk-Around Inspection](#).
6. **Battery** – Charge as required.
7. **Fuel** – (Combustion Engine Powered Machines) Add the proper fuel as necessary.
8. **Engine Oil Supply** – Ensure that the engine oil level is at the full mark on the dipstick and the filler cap is secure.
9. **Fluid Levels** – Be sure to check the engine oil and the hydraulic oil levels.
10. **Accessories/Attachments** – Refer to the Accessories section in this manual or the accessory installed upon the machine for specific inspection, operation, and maintenance instructions.
11. **Function Check** – Once the Walk-Around Inspection is complete, perform a functional check of all systems in an area free of overhead and ground level obstructions. Refer to [Section – Machine Controls, Indicators, And Operation](#) for more specific instructions on the operation of each function.

- Platform Gate** – Keep gate and surrounding area clean and unobstructed. Ensure the gate closes properly and is not bent or damaged. Keep gate closed at all times except when entering/exiting the platform and loading/unloading materials.



- Lanyard Attach Points** – JLG Industries, Inc. recommends personnel in the platform wear a full body harness with a lanyard attached to an authorized lanyard anchorage point.

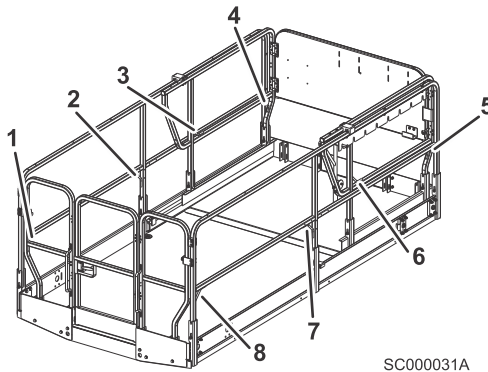

⚠ WARNING

If the machine does not operate properly, turn off the machine immediately! Report the problem to the proper maintenance personnel. Do not operate the machine until it is declared safe for operation.

2.4 WALK-AROUND INSPECTION

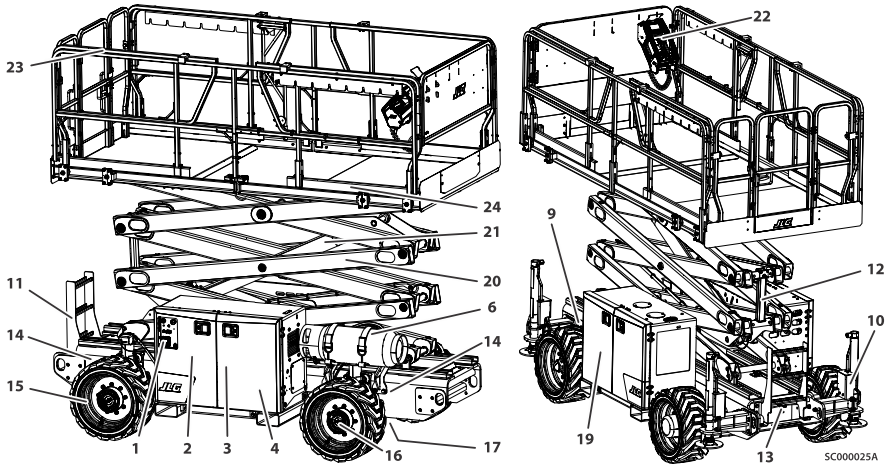

Figure 3. RT2669, RT3369

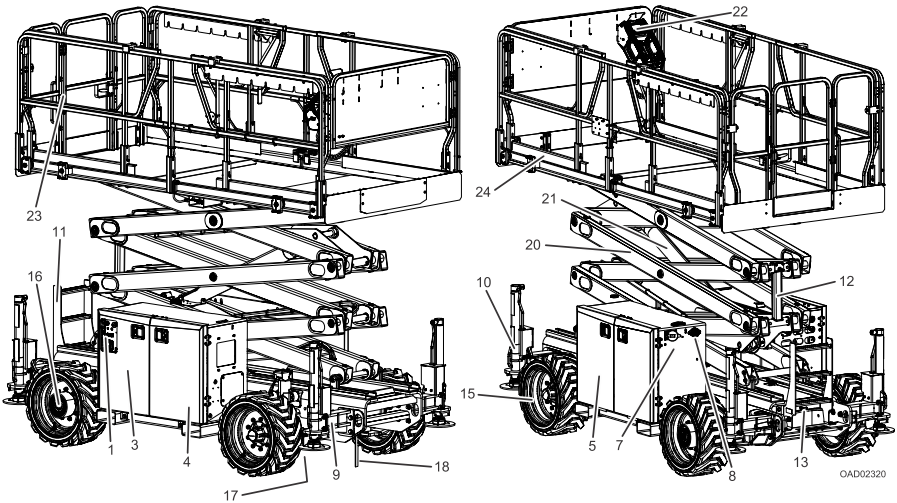

Figure 4. ERT2669, ERT3369

Begin the Walk-Around Inspection at Item 1 as noted on the diagram. Continue to the right (counterclockwise viewed from top) checking each item in sequence for the conditions listed in the following checklist.

⚠ WARNING

To avoid possible injury, be sure machine power is off during walk-around inspection.

NOTICE

Do not overlook visual inspection of chassis underside. Checking this area often results in discovery of conditions which could cause extensive machine damage.

INSPECTION NOTE: On each item, make sure there are no loose or missing parts, that they are securely fastened, and that no visible damage exists in addition to any other criteria mentioned.

1. **Ground Control Station** – Placard secure and legible, control switches return to neutral position when activated and released, emergency stop switch functions properly. Control markings legible.
2. **Fuel Tank** – Filler cap secure, no damage or leaks.
3. **Hydraulic Tank** – Recommended hydraulic fluid level on level indicator on tank. Breather cap secure and working. No damage or leaks.
4. **Main Control Valve** – No unsupported wires or hoses; no damaged or broken wires.
5. **Battery Installation (If Equipped)** – Refer to Inspection Note.
6. **Propane Tank (If Equipped)** – Refer to Inspection Note.
7. **Battery Charger (If Equipped)** – Refer to Inspection Note.
8. **Battery Disconnect (If Equipped)** – Refer to Inspection Note.
9. **Front Oscillating Axle** – Refer to Inspection Note.
10. **Leveling Jacks Assembly (If Equipped)** – Refer to Inspection Note.
11. **Ladder** – No damage, securely attached.
12. **Safety Prop** – Refer to Inspection Note.
13. **Manual Descent** – Refer to Inspection Note.
14. **QuikLevel Advanced (Dual Oscillating Axles) (If Equipped)** – Refer to Inspection Note.
15. **Wheels and Tires** – Properly secured, no missing lug nuts. Inspect wheels for damage and corrosion. Refer to Section 6, Tires and Wheels.
16. **Wheel Drive Hub** – No evidence of leakage. Refer to Inspection Note.
17. **Spindle, Tie Rod, and Steer Linkage** – No loose or missing parts, no visible damage. No steer cylinder leaks or damage.
18. **Static Strap (If Equipped)** – Refer to Inspection Note.

19. **Engine Installation (If Equipped)** – Engine oil to full mark on dipstick, oil filler cap secure. Muffler/exhaust system properly secured, no leakage. Air filter assembly secure, no loose or missing parts, element clean. Radiator cap secure, coolant to correct level.
20. **Scissor Arms and Wear Pads** – Refer to Inspection Note.
21. **Lift Cylinder** – Refer to Inspection Note.
22. **Platform Control Station** – Placard secure and legible, control lever and switches return to neutral when activated and released, all switch guards are in place, trigger switch and emergency stop switch function properly, Operation & Safety manual in storage box.
23. **Platform/Handrail Installation (not shown)** – Refer to Inspection Note.
24. **Platform Extension Stops and Rollers** – Extension stops secure and undamaged. Rollers are undamaged, free of debris, and operate properly.

2.5 FUNCTION CHECK

Perform the Function Check as follows:

1. From the Ground Control Station with no load in the platform:
 - a. Ensure all guards protecting switches are in place.
 - b. Operate all functions (refer to Section 3 for Ground Controls and Indicators).
 - c. Ensure all machine functions are disabled when the Emergency Stop button is activated.
 - d. Check that auxiliary descent, lift down operates with engine off and power on.
 - e. Check that manual descent operates properly (refer to Section 4 for more information).

2. From the Platform Control Station:
 - a. Ensure that the control console is firmly secured in the proper location.
 - b. Ensure all guards protecting switches are in place.
 - c. With the platform elevated on a smooth, firm, level surface with no overhead obstructions, drive the machine to check if the high drive cutout speed limit is engaged at the height indicated in the table below:

Model	Height
RT2669, ERT2669	70 in (1.78 m)
RT3369, ERT3369	80 in (2.03 m)

- d. Ensure that all machine functions are disabled when the Emergency Stop button is activated.
 - e. Ensure all machine functions stop when function control is released or when joystick trigger is released.
3. With the platform in the transport (stowed) position:
 - a. Drive the machine on a grade, not to exceed the rated gradeability, and stop to ensure the brakes hold.
 - b. Check the tilt indicator light to verify proper operation. The light should be illuminated if tilted beyond allowed settings shown in the table below:

Model	Lift Up and Drive prevented when elevated and tilted Front to Back beyond the following limits:	Lift Up and Drive prevented when elevated and tilted Side to Side beyond the following limits:
RT2669, ERT2669	3°	4° at 0% — 55% Capacity
		3° at 56% — 75% Capacity
		2.5° at 76% — 100% Capacity
RT3369, ERT3369	3°	3.5° at 0% — 35% Capacity
		3.0° at 36% — 55% Capacity
		2.5° at 56% — 100% Capacity

2.6 OSCILLATING AXLE - LOCKOUT CYLINDER TEST (IF EQUIPPED) (CE/UKCA MARKETS ONLY)

NOTICE

Lockout cylinder system test must be performed quarterly, any time a system component is replaced, or when improper system operation is suspected.

Note: Ensure platform is fully lowered prior to beginning lockout cylinder test, and that the surface used to approach the ramp is flat and level.

2.6.1 Left Side Wheel Test

1. Place a 4 in (10.16 cm) high block with ascension ramp in front of left wheel of the oscillating axle.
2. From platform control station, select low drive speed.
3. Set the drive control switch into position and carefully drive the machine up ascension ramp until left oscillating axle wheel is on top of block.
4. Verify the axle oscillates to maintain contact with the ground/ramp. (All four wheels on the ground).
5. Raise machine platform above stowed position to drive cutout height.
6. Carefully drive the machine back off the block and ramp.
7. Have an assistant check to see that the left oscillating axle wheel that was on the block is in position on the ground. The axle should oscillate so that all four wheels maintain contact with the ground.
8. In the current position (platform raised and all four on flat and level surface), carefully drive machine up the ramp block again.
9. Have an assistant check to verify that the axle did not oscillate and remained locked (one wheel is off of the ground).
10. Carefully drive the machine back off the block and ramp.
11. Lower the machine platform; the lockout cylinder should then release and allow the axle to oscillate. It may be necessary to activate drive to release cylinders.
12. If the lockout cylinders do not function properly, have qualified personnel correct the malfunction prior to any further operation.

2.6.2 Right Side Wheel Test

1. Place a 4 in (10.16 cm) high block with ascension ramp in front of right wheel of the oscillating axle.
2. From platform control station, select LOW drive speed.
3. Set the drive control switch into position and carefully drive the machine up ascension ramp until right oscillating axle wheel is on top of block.
4. Verify the axle oscillates to maintain contact with the ground/ ramp. (All four wheels on the ground).
5. Raise machine platform above stowed position to drive cutout height.
6. Carefully drive the machine back off the block and ramp.

7. Have an assistant check to see that the right oscillating axle wheel that was on the block is in position on the ground. The axle should oscillate so that all four wheels maintain contact with the ground.
8. In the current position (platform raised and all four on flat and level surface), carefully drive machine up the ramp block again.
9. Have an assistant check to verify that the axle did not oscillate and remained locked (one wheel is off of the ground).
10. Carefully drive the machine back off the block and ramp.
11. Lower the machine platform; the lockout cylinder should then release and allow the axle to oscillate. It may be necessary to activate drive to release cylinders.
12. If the lockout cylinders do not function properly, have qualified personnel correct the malfunction prior to any further operation.

2.7 OSCILLATING AXLE — LOCKOUT CYLINDER TEST (IF EQUIPPED) (ALL MARKETS EXCEPT CE/UKCA)

NOTICE

Lockout cylinder system test must be performed quarterly, any time a system component is replaced, or when improper system operation is suspected.

Note: Ensure platform is fully lowered prior to beginning lockout cylinder test, and that the surface used to approach the ramp is flat and level.

2.7.1 Left Side Wheel Test

1. Place a 4 in (10.16 cm) high block with ascension ramp in front of left wheel of the oscillating axle.
2. From platform control station, select low drive speed.
3. Set the drive control switch into position and carefully drive the machine up ascension ramp until left oscillating axle wheel is on top of block.
4. Verify the axle oscillates to maintain contact with the ground/ramp. (All four wheels on the ground).
5. Raise machine platform above stowed position to drive cutout height.
6. Carefully drive the machine back off the block and ramp.
7. Have an assistant check to see that the left oscillating axle wheel that was on the block remains elevated in position off of the ground.
8. Return the machine to the stowed position. The lockout cylinder should release and allow the wheel to rest on the ground. It may be necessary to activate drive to release the cylinder.

9. If the lockout cylinders do not function properly, have qualified personnel correct the malfunction prior to any further operation.

2.7.2 Right Side Wheel Test

1. Place a 4 in (10.16 cm) high block with ascension ramp in front of right wheel of the oscillating axle.
2. From platform control station, select LOW drive speed.
3. Set the drive control switch into position and carefully drive the machine up ascension ramp until right oscillating axle wheel is on top of block.
4. Verify the axle oscillates to maintain contact with the ground/ ramp. (All four wheels on the ground).
5. Raise machine platform above stowed position to drive cutout height.
6. Carefully drive the machine back off the block and ramp.
7. Have an assistant check to see that the right oscillating axle wheel that was on the block remains elevated in position off of the ground.
8. Return the machine to the stowed position. The lockout cylinder should release and allow the wheel to rest on the ground. It may be necessary to activate drive to release the cylinder.
9. If the lockout cylinders do not function properly, have qualified personnel correct the malfunction prior to any further operation.

2.8 QUIKLEVEL ADVANCED TEST (IF EQUIPPED)

NOTICE

This test must be performed quarterly, any time a system component is replaced, or when improper system operation is suspected.

Note: Ensure platform is fully lowered prior to beginning test, and that the surface used to approach the ramp is flat and level.

1. Place a block with ascension ramp behind the left rear tire.

Note: The height of the ramp should equal at least half of the amount of tire travel to oscillate the axle.

2. From the platform control station, select low drive speed and press the drive function button.
3. Drive the machine in reverse so the rear left tire ascends the ramp and stops on the block. The rear axle should not oscillate.

User Responsibilities, Machine Preparation, and Inspection

4. Verify the front axle oscillates approximately halfway to maintain contact with the ground/ramp (all four tires on the ground).
5. With the machine in the configuration resulting from the previous step (rear left tire on the ramp), press the QuikLevel Advanced button and engage the joystick forward.
6. Once the platform and ground alarms both sound three times, QuikLevel Set is complete. Have an assistant use an external digital level to verify the chassis is level within + / - 1°.
7. With the machine in the configuration resulting from the previous step (chassis level after QuikLevel Set), engage the joystick backwards to perform QuikLevel Return. Have an assistant verify the chassis rotates in the opposite direction when compared to QuikLevel Set.
8. Once the platform and ground alarms both sound two times, QuikLevel Return is complete.
9. Drive the machine off the ramp so all four tires are on flat and level ground.
10. Verify the following conditions:
 - The chassis and rear axle appear to be aligned.
 - No DTCs were activated while driving.
 - High Drive Speed is permitted.
11. Place the block with ascension ramp in front of the right front tire.
12. Drive the machine forward so the tire ascends the ramp until the front axle is completely oscillated.
13. Press the QuikLevel Advanced button the press the steer switch to the left to tilt the machine until DTC 0062 is activated and the platform and ground alarms both sound three times.
14. Engage the joystick backwards to realign the chassis and rear axle and then drive off the ramp.
15. If the system does not function properly, have qualified personnel correct the malfunction prior to any further operation.

SECTION 3

Machine Controls, Indicators, and Operation

3.1 GENERAL

NOTICE

The manufacturer has no direct control over machine application and operation, the user and operator are responsible for conforming with good safety practices.

This section provides the necessary information needed to understand machine controls and indicators.

⚠ WARNING

Do not raise platform unless the machine is on a smooth, firm surface, within the limits of the maximum operating slope, free of obstructions and holes.

To avoid serious injury, do not operate machine if any control levers or toggle switches controlling platform movement do not return to the off or neutral position when released.

If the platform does not stop when a control switch or lever is released, use the emergency stop switch to stop the machine.

3.2 DESCRIPTION

This machine is a Mobile Elevating Work Platform (MEWP) used to position personnel along with their necessary tools and materials at work locations.

This MEWP has a primary operator control station in the platform. From this control station, the operator can drive and steer the machine in both forward and reverse directions, raise and lower the platform, and set the machine leveling jacks (if equipped).

The machine can be driven on a smooth, firm surface within the limits of the maximum operating slope from an elevated platform position.

The machine also has a ground control station which can override the platform control station. Ground controls operate lift up and down. Except for performing inspections and function checks, ground controls are to be used only in an emergency to lower the platform to the ground should the operator in the platform be unable to do so.

3.3 OPERATING CHARACTERISTICS AND LIMITATIONS

3.3.1 Placards

Important points to remember during operation are provided at the control stations by DANGER, WARNING, CAUTION, NOTICE, IMPORTANT and INSTRUCTION placards. This information is placed at various locations for the express purpose of alerting personnel of potential hazards constituted by the operating characteristics and limitations of the machine. See foreword for definitions of placard safety signal words.

3.3.2 Capacities

Raising platform above horizontal with or without any load in platform is based on the following criteria:

1. Machine is positioned on a smooth, firm surface within the limits of the maximum operating slope.
2. Load is within manufacturer's rated capacity.
3. All machine systems are functioning properly.

3.3.3 Stability

This machine, as originally manufactured by JLG and operated within its rated capacity on a smooth, firm surface, within the limits of the maximum operating slope, provides a stable aerial platform for all platform positions.

3.4 PLATFORM LOADING

The platform maximum rated load capacity is shown on a placard located on the platform billboard and ground control station and is based upon the machine positioned on a smooth, firm surface within the limits of the maximum operating slope. Refer to [Section – Machine Specifications](#) for the maximum platform capacity.

The platform is entered through an entry gate at the rear of the platform. Keep entry gate closed at all times except when entering/exiting the platform and loading/unloading materials.

Note: It is important to remember that the load should be evenly distributed on the platform. The load should be placed near the center of the platform when possible.

3.5 BATTERY CHARGING (ERT MACHINES)

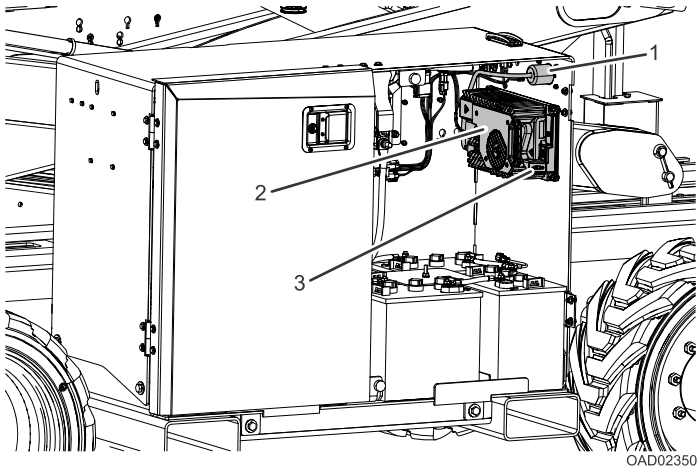

1. AC Input Plug

2. Charger Assembly

3. LED Indicator Panel

1. Connect the charger AC input plug to a grounded outlet using a 3 wire heavy duty extension cord.
2. The charge cycle is complete when the single green LED light on the hood between the AC plug and battery disconnect becomes solid green. Additionally, the green LEDs on the top and bottom panels of the battery charger illuminate.

⚠ CAUTION

Only plug the charger into a properly installed and grounded outlet. Do not use ground adapters or modify plug in any way. Do not touch non-insulated portion of output connector or non-insulated battery terminal.

Do not operate charger if the AC supply cord is damaged, or if the charger has received a sharp blow, been dropped, or otherwise damaged in any way.

Always disconnect the charger AC supply before making or breaking the positive/negative connections to the battery.

Do not open or disassemble charger.

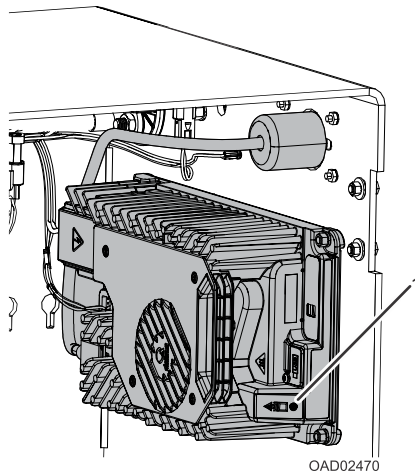

1. LED Indicator Panel

- **AC Power On:** Blue LED on
- **Low State of Charge:** Bottom Panel — Green LED flashing; Top Panel — Green LED off
- **High State of Charge:** Bottom Panel — Green LED on; Top Panel — Green LED flashing
- **Charge Complete:** Bottom Panel — Green LED on; Top Panel — Green LED on
- **Fault Indicator:** Red LED on
- **External Error Condition Caution:** Amber LED flashing

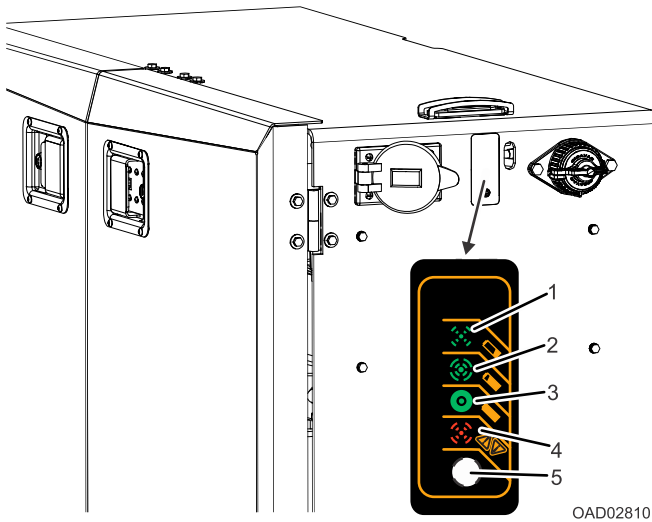

- **(1) Charging (Low State of Charge):** Green LED slow flash
- **(2) Charging (High State of Charge):** Green LED fast flash
- **(3) Full Charge (100%):** Solid green LED
- **(4) Charger Fault:** Amber LED rapid flash
- **(5) LED Light**
- **No AC Current:** LED is off

3.6 GROUND CONTROL STATION

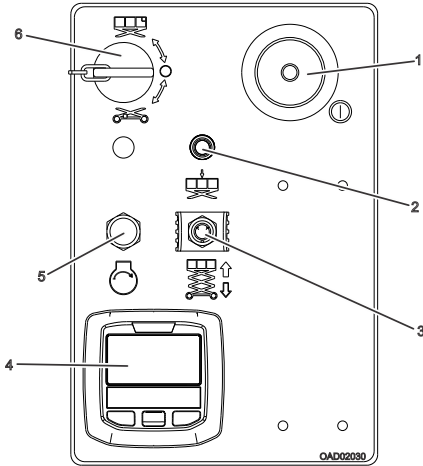

Figure 5. RT Machines

- 1. Emergency Stop Switch
- 2. Overload Indicator (LSS)
- 3. Lift/Lower Switch
- 4. Display Gauge or Hourmeter
- 5. Engine Start Switch
- 6. Ground/Platform/OFF Key Selector Switch

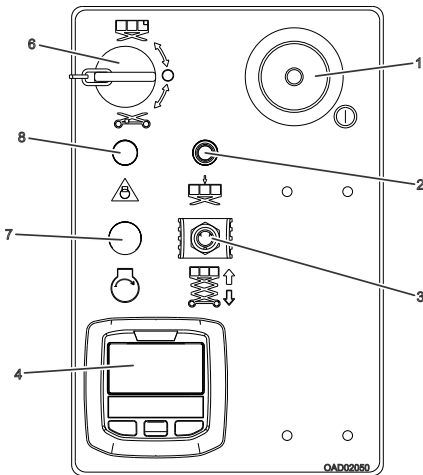

Figure 6. ERT Machines

- 1. Emergency Stop Switch
- 2. Overload Indicator (LSS)
- 3. Lift/Lower Switch
- 4. Display Gauge or Hourmeter
- 5. Not Used
- 6. Ground/Platform/OFF Key Selector Switch
- 7. Genset Start Switch (If Equipped)
- 8. Genset Indicator (If Equipped)

3.6.1 Ground Control Station Functions

⚠ WARNING

Do not operate from ground control station with personnel in the platform except in an emergency.

1. **Emergency Stop Switch** — A two-position, red, mushroom-shaped emergency stop switch, when positioned to ON with the power selector switch positioned to ground, furnishes operating power to the ground control station. In addition, the switch can be used to turn off power to the function controls in the event of an emergency. Power is turned on by pulling the switch out (on), and is turned off by pushing the switch in (off).

NOTICE

Always position emergency stop switch to the off position (pushed in) when machine is not in use.

2. **Overload Indicator (LSS)** — The Overload Indicator indicates when the platform has been overloaded. An audible alarm will also signal when the platform is overloaded.

Note: If the Overload Indicator is illuminated, further elevation will be prevented. Reduce the weight in the platform so as to not exceed the rated workload indicated on the capacity decal, then the controls will work again.

3. **Lift/Lower Switch** — A two position momentary contact lift/lower control switch raises and lowers the platform when positioned to up or down.
4. **Display Gauge Options** —

1. *Digital Display* —

- **RT Machines:** *Displays the number of hours the machine has been operated, fuel status, glow plug status, and any active DTCs.*
- **ERT Machines:** *Displays the number of hours the machine has been operated, current battery charge, battery temperature, battery charge status (if plugged in), and any active DTCs.*

2. *Hourmeter* — *Registers the amount of time the machine has been in use. The hourmeter registers up to 9,999.9 hours and cannot be reset*

- **RT Machines:** *Displays the number of hours the machine's engine has been in use.*
- **ERT Machines:** *Displays the number of hours the machine's drive function or any other function has been in use.*

5. **Engine Start Switch** — A momentary contact push button type switch that supplies electrical power to the starter solenoid when the emergency stop switch is in the on position and the start button is pressed.

- Ground/Platform/OFF Key Selector Switch** — A three position, key-operated power select switch supplies operating power to the platform or ground controls, as selected. When positioned to platform, the switch provides power to the emergency stop switch at the platform controls. When positioned to ground, the switch provides power to the ground control. The ground control emergency stop switch provides power to the key switch. With the power select switch in the center off position, power is shut off to both platform and ground controls and the key can be removed to disable the machine.

Note: With the power selector switch in the off position, the key can be removed to disable the machine.

Note: Positioning the key switch from ground to platform or platform to ground while the engine is running may cause the engine to shut off after a brief period.

- Genset Start Switch (If Equipped)** — This button starts the genset system engine. This system will continuously monitor the battery pack charge and its starter battery.
- Genset Indicator (If Equipped)** — This will illuminate when a genset system fault is present.

3.7 GROUND CONTROL STATION DISPLAY GAUGE

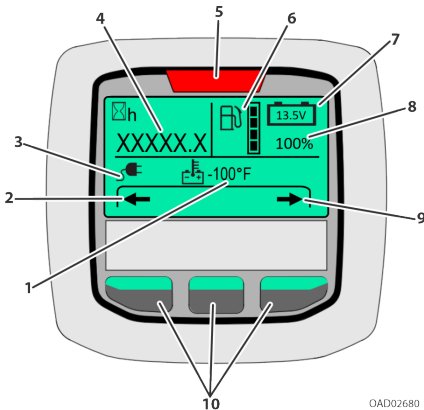

- Battery Temperature Indicator
- Navigate Back Arrow
- Charger Connected Indicator (ERT Machines Only)
- Machine Hours
- Indicator Lamp (Fault)
- Fuel Level Indicator (RT Machines Only)
- Control System Voltage (12V System)
- State-of-Charge Indicator (48V System)
- Navigate Forward Arrow
- Navigation Buttons

The Display Gauge shows machine hours and Diagnostic Trouble Codes (DTCs). During machine start up, with no active DTCs in the control system, the splash screen will show for 3 seconds and then switch to main screen. If there is an active DTC while powering up the machine, the splash screen will show for 3 seconds, and then launch the Diagnostics Screen. The indicator lamp will light when there is an active DTC in the Fault Log.



Figure 7. Splash Screen

The Diagnostic Screen will show active and inactive faults from the JLG Control System on the screen. An asterisk (*) will be displayed to show active faults.

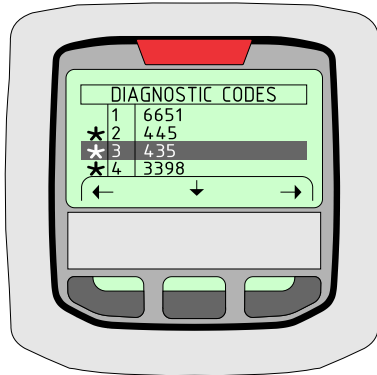

Figure 8. Diagnostic Screen

3.8 PLATFORM CONTROL STATION

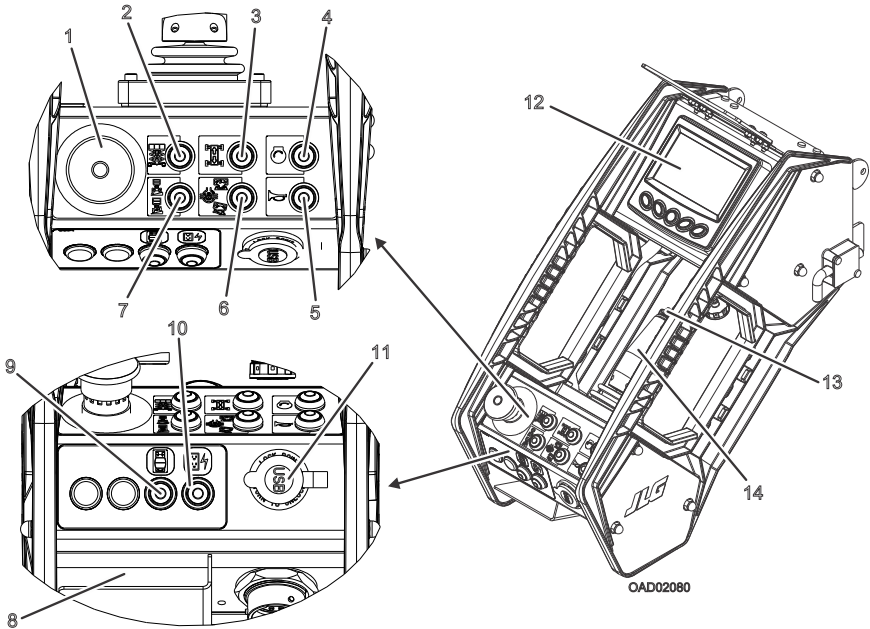

Figure 9. RT Machines

- | | |
|--|--|
| 1. Emergency Stop Switch | 8. Mobile Phone Slot |
| 2. Lift Select Switch | 9. Dual Fuel Selection (If Equipped) |
| 3. Drive Select Switch | 10. Generator Start Switch (If Equipped) |
| 4. Engine Start Switch | 11. USB Charge Port |
| 5. Horn | 12. Indicator Display |
| 6. Speed Select Switch | 13. Steer Control Switch |
| 7. Leveling Jacks OR QuikLevel Advanced Switch | 14. Joystick Controller with Trigger (Enable) Switch |

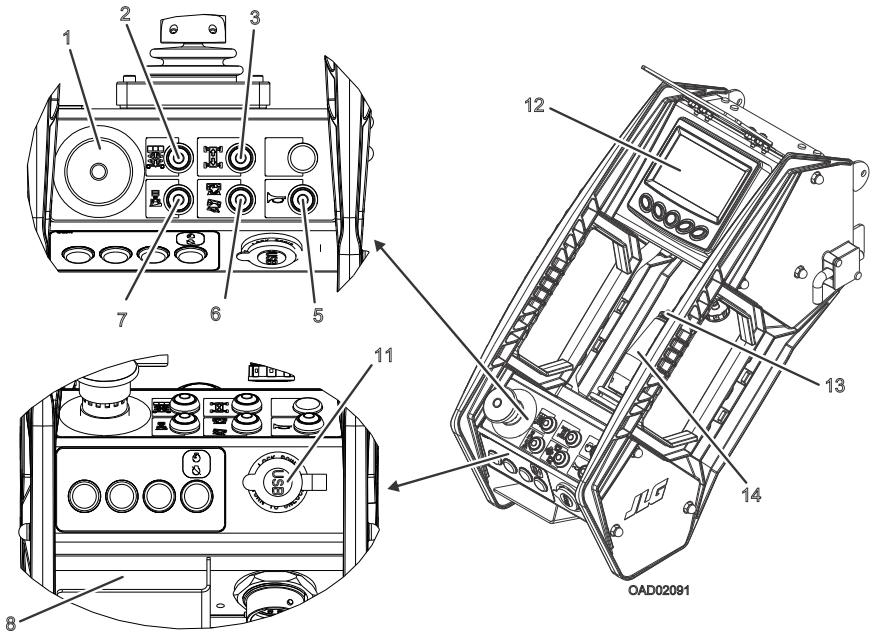

Figure 10. ERT Machines

- | | |
|--|--|
| 1. Emergency Stop Switch | 8. Mobile Phone Slot |
| 2. Lift Select Switch | 9. Not Used |
| 3. Drive Select Switch | 10. Not Used |
| 4. Not Used | 11. USB Charge Port |
| 5. Horn | 12. Indicator Display |
| 6. Speed Select Switch | 13. Steer Control Switch |
| 7. Leveling Jacks Switch (If Equipped) | 14. Joystick Controller with Trigger (Enable) Switch |

3.8.1 Platform Control Station Functions

1. **Emergency Stop Switch** — A two-position, red, mushroom-shaped emergency stop switch, when positioned to ON with the power selector switch positioned to ground, furnishes operating power to the ground control station. In addition, the switch can be used to turn off power to the function controls in the event of an emergency. Power is turned on by pulling the switch out (on), and is turned off by pushing the switch in (off).

NOTICE

Always position emergency stop switch to the off position (pushed in) when machine is not in use.

2. **Lift Select Switch** — The lift switch provides for raising and lowering the platform. Lift is activated by pressing the switch and position the joystick forward or backward.

3. **Drive Select Switch** — The drive switch provides for driving the machine. Drive is activated by pressing the switch and position the joystick forward or backward.
4. **Engine Start Switch (If Equipped)** — A momentary contact, push button type switch that supplies electrical power to the starter solenoid when the emergency stop switch is in the on position and the start button is pressed.

Note: When diesel engine-powered machines are turned on, the glow plug indicator will illuminate on the platform control indicator display, regardless of engine or ambient temperature. Do not start the engine until the glow plug indicator light disappears.



5. **Horn** — This push button switch, when activated, permits the operator to warn jobsite personnel when the machine is operating in the area.
6. **Speed Select Switch** — This switch alternates between high drive speed (rabbit) and low drive speed (turtle). If equipped with differential lock (RT machines, 2WD only) the function may be engaged with this switch.

Note: High/low drive speeds are disabled when the platform is raised above the high drive cutout height (70 — 90 in [1.78 — 2.3 m], depending on machine). At this height, drive speed is restricted to 0.3 – 0.5 mph (0.5 – 0.8 kph), depending on machine.

CAUTION

Do not operate machine if high drive speed operates when platform is raised above the high drive cutout height.

CAUTION

Do not use high drive speed when driving in close quarters or when driving in reverse.

7. **Leveling Jacks or QuikLevel Advanced Switch (If Equipped)** — This switch engages the leveling jacks or the QuikLevel Advanced system
8. **Mobile Phone Slot** — Provides an enclosed area to the operator in which to place a mobile phone device.
9. **Dual Fuel Selection (If Equipped)** — Switches between LP and gas usage when pressed.
10. **Generator Switch (If Equipped)** — Enables the generator that supplies AC power to the platform.
11. **USB Charge Port** — Provides a USB charge port to the operator.
12. **Indicator Display** — Shows a variety of machine operation information. Refer to ABCD for more information.

13. **Steer Control Switch** — The thumb-operated steer switch on top of the joystick controller activates the steer wheels in the direction it is moved (right of left).
14. **Joystick Controller with Trigger (Enable) Switch** — The joystick controls four functions: drive; drive/lift speed; and leveling jacks or dual oscillating axles (if equipped). All function buttons must be selected prior to engaging the joystick. The speed is controlled by the travel distance of the joystick.

Note: If the machine is also equipped with a footswitch (Korea market only), the footswitch must be pressed in conjunction with the trigger (enable) switch located on the joystick controller. Power is removed from the platform controls when the footswitch is released.

Note: Once a function has been selected, the operator has seven seconds to engage the function.

3.9 INDICATOR DISPLAY

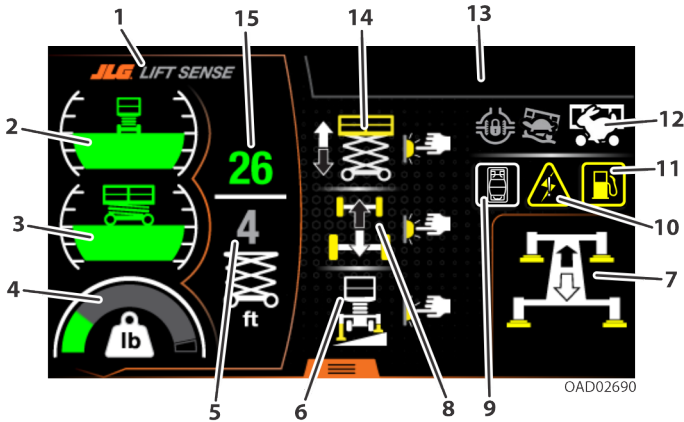

Figure 11. RT Machines (If Equipped with Leveling Jacks)

- | | |
|---|---|
| <ol style="list-style-type: none"> 1. Lift Sense Pane 2. Side to Side Tilt 3. Front to Back Tilt 4. Platform Load Gauge 5. Current Platform Height 6. Leveling Jacks Indicator (If Equipped) 7. Leveling Jacks Status (If Equipped) 8. Drive Select Indicator | <ol style="list-style-type: none"> 9. Dual Fuel (LP Selection) 10. System Fault Indicator 11. Low Fuel Indicator 12. Drive Speed 13. DTC Messages Display 14. Lift/Lower Indicator 15. Maximum Allowed Platform Height |
|---|---|

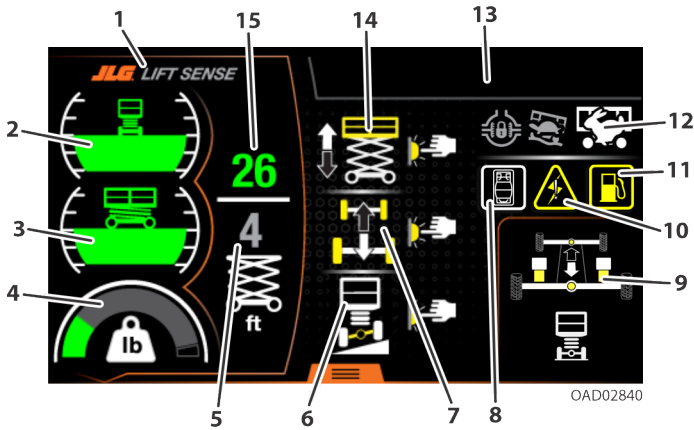

Figure 12. RT Machines (If Equipped with QuikLevel Advanced)

- | | |
|---|--|
| 1. Lift Sense Pane | 9. QuikLevel Advanced Indicator Status (If Equipped) |
| 2. Side to Side Tilt | 10. System Fault Indicator |
| 3. Front to Back Tilt | 11. Low Fuel Indicator |
| 4. Platform Load Gauge | 12. Drive Speed |
| 5. Current Platform Height | 13. DTC Messages Display |
| 6. QuikLevel Advanced Indicator (If Equipped) | 14. Lift/Lower Indicator |
| 7. Drive Select Indicator | 15. Maximum Allowed Platform Height |
| 8. Dual Fuel (LP Selection) | |

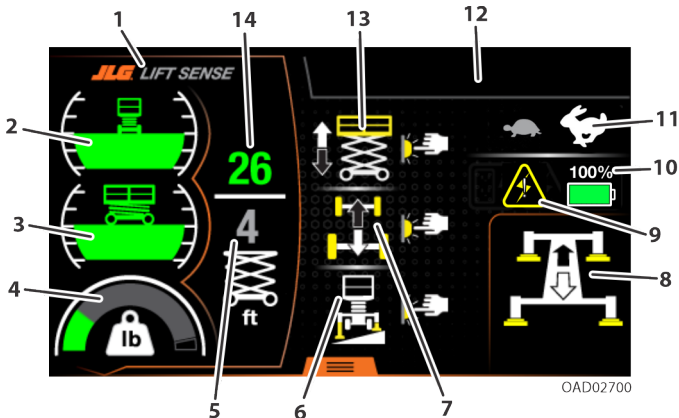

Figure 13. ERT Machines (If Equipped with Leveling Jacks)

- | | |
|---|--|
| 1. Lift Sense Pane | 8. Leveling Jacks Status (If Equipped) |
| 2. Side to Side Tilt | 9. System Fault Indicator |
| 3. Front to Back Tilt | 10. Battery State-of-Charge |
| 4. Platform Load Gauge | 11. Drive Speed |
| 5. Current Platform Height | 12. DTC Messages Display |
| 6. Leveling Jacks Indicator (If Equipped) | 13. Lift/Lower Indicator |
| 7. Drive Select Indicator | 14. Maximum Allowed Platform Height |

3.9.1 Indicator Display Functions

⚠ CAUTION

If the tilt indicator warning light/alarm is activated when platform is raised, lower platform and drive to a smooth firm surface within the limits of the maximum operating slope.

⚠ CAUTION

Do not operate machine if high drive speed operates when platform is raised above the stowed position.

Battery State-of-Charge

Displays the battery state-of-charge for ERT machines in 5% increments. The bar remains green until 25%, after which it turns red and reads "LOW" until it reaches above 25% again.

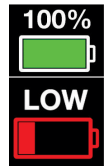

Current Height

Current platform height (bottom number).



Drive Select Indicator

Indicates if drive mode has been selected.

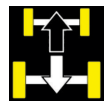

Drive Speed

- **RT Machines:** Indicates whether high drive speed (rabbit), low drive speed (turtle), or differential lock has been selected.
- **ERT Machines:** Indicates whether high drive speed (rabbit) or low drive speed (turtle) has been selected.



DTC Messages Display

Displays any active DTC messages. The system fault indicator will also flash the appropriate flash code for the DTC. If no DTCs are active, this area of the display remains blank.

Dual Fuel (LP Selection)

Indicates when LP has been selected.



Front to Back Tilt

Shows the current level of front to back tilt. A red warning light on the display illuminates and an audible alarm sounds when the chassis is at or beyond the tilt cutout settings.



Glow Plug (not shown)

When diesel engine-powered machines are turned on, the glow plug indicator will illuminate on the display, regardless of engine or ambient temperature. Do not start the engine until the glow plug indicator light disappears.



Leveling Jacks Indicator (If Equipped)

Indicates when the leveling jacks function has been selected.



Leveling Jacks Status (If Equipped)

Displays the current status of leveling jacks. When the leveling jacks are extended or retracted, the appropriate arrow will flash on the display.

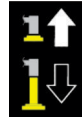

- **Leveling Jacks Stowed**



- **Leveling Jacks Extending**

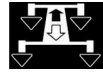

- **Leveling Jacks Set**

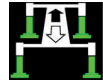

- **Leveling Jacks Retracting**

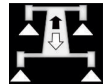

- **Leveling Jacks Fault**



Lift/Lower Indicator

Indicates if lift mode has been selected.

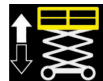

LiftSense Pane

The LiftSense system measures side to side tilt, current platform height, and platform load in order to provide a variable work envelope. As these three values change in the work environment, the maximum allowed platform height is calculated and displayed to the operator.

The LiftSense pane can be hidden by pressing the far left button of the display. Press this button again to return the pane to view.

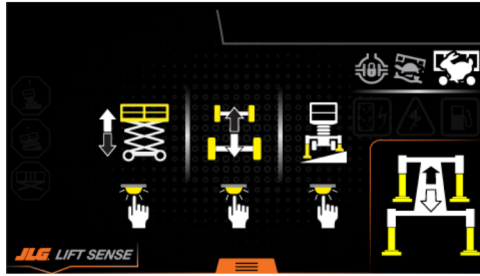

Figure 14. LiftSense Pane Hidden

Low Fuel Indicator

Illuminates when fuel remaining in the fuel tank is low.



Maximum Allowed Platform Height

Maximum allowed platform height as calculated by LiftSense system. The number is green when maximum platform height can be reached. If the machine is unable to reach maximum height, the number will change from green to yellow.



Platform Load Gauge

Displays the calculated load on the platform. The gauge bar remains green if platform load is less than the rated capacity. If the platform is determined to be overloaded, a red warning light on the display illuminates and an audible alarm sounds.



Note: If the Overload Indicator is illuminated, further elevation will be prevented. Reduce the weight in the platform so as to not exceed the rated workload indicated on the capacity decal, then the controls will work again.

QuikLevel Advanced Indicator (If Equipped)

Indicates if QuikLevel Advanced function has been selected.



QuikLevel Advanced Status (If Equipped)

- **Rear Axle Extend**
- **Rear Axle Retract**



- Rear Axle Aligned



- Rear Axle Not Aligned



- Drive at Height Allowed



- Drive at Height Not Allowed



- Speed Restricted (Low Speed)

When rear axle and chassis are not aligned, drive speed is restricted.



Side to Side Tilt

Shows the current level of side to side tilt. A red warning light on the display illuminates and an audible alarm sounds when the chassis is at or beyond the tilt cutout settings.



System Fault Indicator

When a system fault has been detected, the upper right hand corner of the display will show the DTC readout. Additionally, the system fault indicator will flash the appropriate distress code.



3.10 NAVIGATING THE INDICATOR DISPLAY



OAD02820

1. At machine start up the machine brand logo will be displayed briefly, followed by the manual/lanyard reminder and home screens.

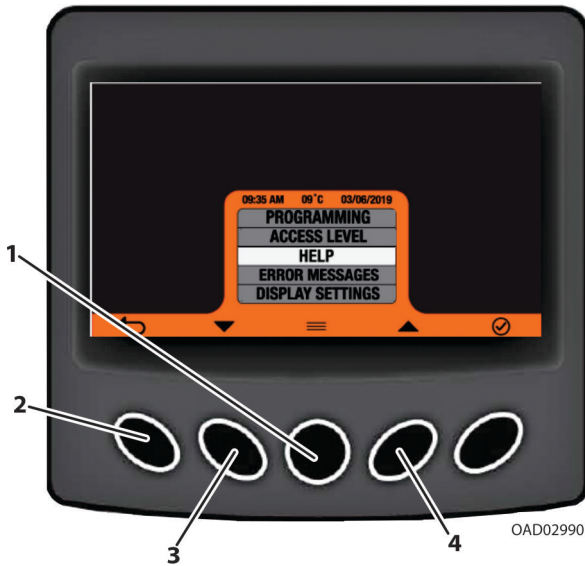

2. To view the submenus, press the menu select button **(1)**.
3. Use the Left and Right Navigation buttons **(3 and 4)** to move through the menu items. When the desired option is highlighted, press the Menu Select button **(1)**.
4. To return to the home screen, press the Left Navigation button **(2)**.
5. Use the Scroll Page Left and Scroll Page Right buttons **(6)** to cycle through the different pages of the menu selection.
6. The page icon **(7)** will inform what page is currently being viewed.
7. To return to the Home Screen, press the Left Navigation button **(5)**.

Note: When navigating the submenus of the display screen, pressing the joystick trigger will return the view to the operating screen.

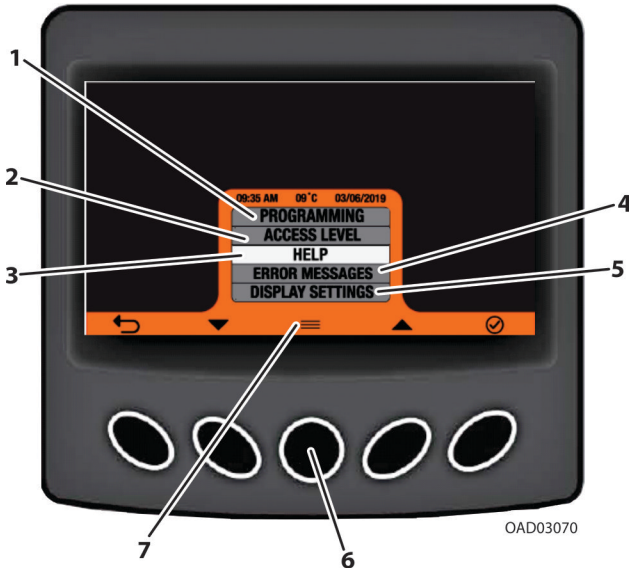

Figure 15. Submenus

1. **Programming:** Provides the interface for updating software. A service level access code is needed. Refer to Service and Maintenance manual for further information.
2. **Access Level:** Allows for elevated levels of machine access when a certain code is entered. The machine's default is Level 2 — Operator Access (no code necessary).
3. **Help:** Provides screens that describe the user interface of the display.
4. **Error Messages:** Shows the last 25 DTCs logged by the machine's control system. Active DTCs will appear with an asterisk (*) beside the code.
5. **Display Settings:** Allows operators to adjust display features (brightness, contrast, time, date, units, etc.).
6. **Menu Select:** Press to display submenu screen.
7. **Help Menu Select:** Press and hold for quick access to Help (3) screens.

3.11 ENGINE OPERATION

Note: When operating a machine at high altitudes, a decrease in machine performance may occur due to a decrease in air density.

When operating a machine at high ambient temperatures, a decrease in machine performance and an increase in engine coolant temperature may occur. Contact JLG Customer Service for operation under abnormal conditions.

3.11.1 Starting Procedure

Note: Perform initial start-up from Ground Controls.

1. Check engine oil before attempting to start engine; if necessary, add oil (refer to Operator Maintenance for details).
2. Pull out the red emergency stop switch (on).
3. Position the platform/ground select switch to the desired operating control station (platform or ground).
4. If operating a dual fuel machine, place the LP/gasoline select switch in the platform to the desired position.

Note: If LPG system is selected, ensure the hand valve on LPG supply tank is opened prior to attempting to start engine.

NOTICE

If engine fails to start promptly, do not crank for an extended period; do not run starter motor for more than 20 seconds. Should engine fail to start once again, allow starter to cool off for 2 to 3 minutes. If engine fails to start after several attempts, refer to engine manual.

5. To start machine:
 - **At Ground Controls:** Position emergency stop switch to on, depress start button, and hold until engine starts.
 - **At Platform Controls:** Position ground and platform emergency stop switch(s) to on, toggle start switch, and hold until the engine starts.

If necessary, activate glow plug switch for up to 20 seconds before starting engine if temperature is below 50° F (10° C).

NOTICE

If indicator lights remain lit after engine start-up, stop engine immediately and determine cause.

NOTICE

Allow engine to warm up before applying any load.

6. After engine has warmed, proceed with operation.

3.12 DUAL FUEL SYSTEM (IF EQUIPPED)

CAUTION

It is possible to switch from one fuel source to the other without allowing the engine to stop. Extreme care must be taken and the following instructions must be followed.

3.12.1 Changing from Gasoline to Liquid Propane Gas (LPG)

1. Start the engine from the platform control station.
2. With the engine under a no load condition, open the hand valve on the LPG supply tank by turning counterclockwise.
3. While the engine is operating, place the two position LPG/gas select switch at the platform control station to LPG.

3.12.2 Changing from LPG to Gasoline

1. With the engine operating on LPG under a no load condition, position the LPG/gas select switch at the platform station to the gas select position.
2. If the engine 'stumbles' because of a lack of gasoline, place the switch to the LPG position until the engine regains smoothness, then return the switch to the gas select position. Repeat as necessary until the engine runs smoothly on gasoline.
3. Close the hand valve on the LPG supply tank by turning clockwise.

3.13 TRAVELING (DRIVING)

WARNING

Do not drive with platform raised except on a smooth, and level surface within the limits of the maximum operating slope, free of obstructions and holes. To avoid loss of travel control or upset on grades and side slopes, do not drive machine on grades or side slopes exceeding those specified in Section 6.

3.13.1 Steering

To steer the machine, the thumb operated steer control switch on the controller handle is positioned to the right for traveling right, or to the left for traveling left. When released, the switch will return to the center- off position and the wheels will remain in the previously selected position. To return the wheels to the straightened position, the switch must be activated in the opposite direction until the wheels are centered.

3.13.2 Traveling Forward

1. Place the power selector switch at the ground control station to platform.

2. Position the emergency stop switch at the platform control station to the on position.
3. Press the drive switch and move the joystick forward and hold for the duration of travel.

Drive speed is determined by the distance the joystick is moved from the center off position. For additional drive speed, position the high drive speed switch to high while operating in the drive forward mode.

3.13.3 Traveling in Reverse

1. Place the power selector switch at the ground control station to platform.
2. Position the emergency stop switch at the platform control station to the on position.
3. Press the drive switch and move the joystick rearward and hold for the duration of travel.

Drive speed is determined by the distance the joystick is moved from the center off position. Do not activate the high drive speed switch when traveling in reverse.

3.14 TRAVELING (GRADE/SIDE SLOPE)

If traveling at high speed up a grade and the incline exceeds 7° — 10° (depending on machine configuration), the drive function will cut back to low speed. The drive pump will shift back into high speed once the incline decreases to 5° — 8° (depending on machine configuration). There will be a two second delay before the machine returns to high speed.

If traveling at high speed down a grade and the incline exceeds 12° — 14° (depending on machine configuration), the drive function will cut back to low speed. The drive pump will shift back into high speed once the incline decreases to 5° — 8° (depending on machine configuration). There will be a two second delay before the machine returns to high speed.

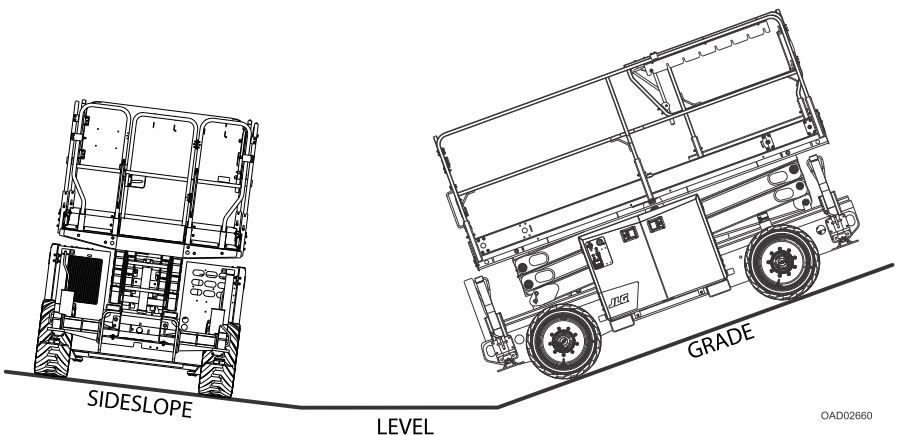

Figure 16. Grade/Side Slope (RT2669, ERT2669)

OAD02660

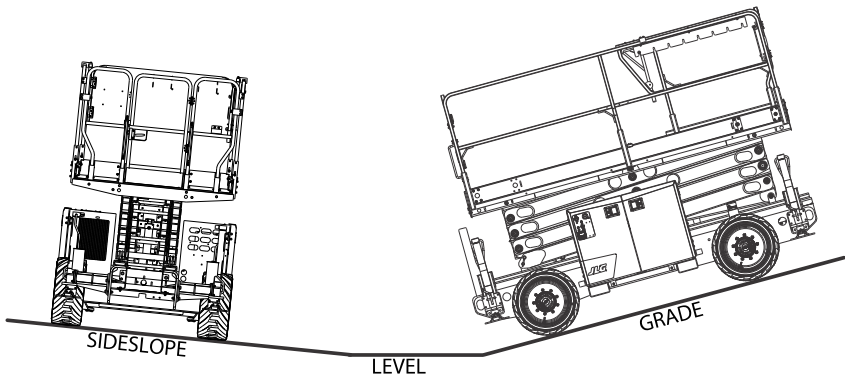

Figure 17. Grade/Side Slope (RT3369, ERT3369)

OAD02670

3.15 PLATFORM

3.15.1 Raising

⚠ WARNING

Do not raise platform except on a smooth, firm, and level surface within the limits of the maximum operating slope, free of obstructions and holes.

1. Position the applicable emergency stop switch(s) to the on position.
2. With the engine running, place the power select switch to desired position (platform or ground).
3. If operating from the ground controls, position the lift switch to up and hold until desired elevation is achieved. If operating from the platform controls, set the lift/drive switch to lift, depress the trigger switch, then move the control handle backward and hold until desired elevation is reached. Lift speed is determined by the distance the control handle is moved from the off center position.

3.15.2 Lowering

WARNING

Ensure scissor arm area is free of personnel prior to lowering platform. Do not lower without completely retracting the platform extension.

If operating from the ground controls, position the lift switch to down and hold until desired elevation is achieved or until platform is fully lowered.

If operating from the platform controls, press the lift switch and then move the control handle forward and hold until desired elevation is reached or until platform is fully lowered.

3.15.3 Arm Guards (If Equipped)

If the machine is equipped with electronic arm guards, the platform will stop lowering at a predetermined height and the machine's beacons will flash at a different rate to warn ground personnel. Machine lowering can continue after a three (3) second delay. Once the lowering function is re-engaged an audible alarm will sound. After a one and a half (1.5) second delay the platform will continue lowering.

3.15.4 Platform Extension

The machine is equipped with a mechanical extension deck that adds 3 ft (0.9 m) to the front or rear of the platform, giving the operator better access to worksites.

To extend the deck, lift up the extension handle so the latch clears the notch on the extension plate. Push forward on the extension handle until desired length is reached. Lower the extension handle and ensure the latch is secured in a notch on the extension plate.

To retract the deck, lift up the extension handle so the latch clears the notch on the extension plate. Pull back on the extension handle to retract the deck to the stowed position. Lower the extension handle and ensure the latch is secured in the first notch on the extension plate.

Maximum capacity of the deck extension is 300 lb (136 kg).

WARNING

Do not lower without completely retracting the platform extension.

3.16 LEVELING JACKS (IF EQUIPPED)

The machine may be equipped with auto-leveling jacks with a manual adjust feature. These leveling jacks are activated through a switch on the platform control station.

3.16.1 Auto-Leveling

1. With the machine in the stowed position, turn the power on and start the machine.
2. Press the leveling jacks button on the front of the platform control station.
3. While squeezing the trigger switch on the joystick, move the joystick forward to lower the leveling jacks.
4. Once the leveling jacks make contact with the ground surface there will be up to a 5 second delay before the actual auto-leveling begins.

Note: Due to varying ground conditions, there may be several delays between machine level corrections. Allow ample time for all leveling adjustments to be completed.

Note: The level adjustment of the machine may still be improved. Refer to Manual Level Adjustment (Trim) for more information.

5. Continue to engage the leveling jacks until the tilt light stops blinking and is no longer lit. The platform and ground alarms will both sound three times to indicate this is complete.

Note: If a 2/5 flash code appears through the system fault light at the platform control station, the machine is unable to level. Reposition and try again.

6. To retract the leveling jacks, press the function button then move the joystick backward. The platform and ground alarms will both sound two times to indicate this is complete.

Note: The tilt indicator shows when the machine is outside the allowable lifting operation. When the machine reaches a position within level of the specific market specification, the tilt light will go out. Once the light is out, the level adjustment of the machine may still be improved. (Refer to Manual Level Adjustment (Trim) section.)

Note: There is a limit switch that senses when all four cylinders are fully retracted and this will light up the four leveling jack lights in the platform control station.

The proximity sensor will not allow the jacks to be extended or retracted when the machine is elevated. If there is a proximity sensor failure the leveling jacks cannot be used.

3.16.2 Manual Level Adjustment (Trim)

Note: There is an override feature on the Leveling Jack system that allows the operator to adjust (trim) the level of the machine to the left or right when the platform is completely lowered. Use the following instructions to adjust the level of the machine.

1. With the machine in the stowed position turn the power on, start machine.
2. Press the leveling jacks button on the front of the platform control station.

3. To adjust (trim) the machine to the right, activate the steer switch on the top of the controller to the right until the desired position is reached.
4. To adjust (trim) the machine to the left, activate the steer switch on the top of the controller to the left until the desired position is reached.

Note: Anytime the trim function is used there is a possibility that the machine may become out of level. At this time the machine will no longer lift but the machine can be lowered.

Note: The machine must be in the stowed position before the trim function is operable.

3.17 QUIKLEVEL ADVANCED (DUAL OSCILLATING AXLES) (IF EQUIPPED)

The machine may be equipped with QuikLevel Advanced, auto-leveling dual oscillating axles with a manual adjust feature. with a manual adjust feature. These axles are activated through a switch on the platform control station.

3.17.1 Auto-Leveling

1. With the machine in the stowed position, turn the power on and start the machine.
2. Press the leveling jacks button on the front of the platform control station.
3. While squeezing the trigger switch on the joystick, move the joystick forward to begin leveling the machine.

Note: Due to varying ground conditions, there may be several delays between machine level corrections. Be sure ample time is allowed for all leveling adjustments to be completed.

Note: The level adjustment of the machine may still be improved. Refer to Manual Level Adjustment (Trim) for more information.

4. Continue to hold the joystick forward until the leveling sequence ends and the platform and ground alarms both sound three times to indicate this is complete.
5. To realign the chassis with the rear axle, press the function button, then move the joystick backwards. The platform and ground alarms will both sound two times to indicate this is complete.

Note: If a 2/5 flash code appears through the system fault light at the platform control station while driving in the stowed position, reattempt to realign the chassis and the rear axle.

Note: The tilt indicator shows when the machine is outside the allowable lifting operation. When the machine reaches a position within level of the specific market specification, the tilt light will go out. Once the light is out, the level adjustment of the machine may still be improved. (Refer to Manual Level Adjustment (Trim) section.)

3.17.2 Manual Level Adjustment (Trim)

Note: There is an override feature on the QuikLevel Advanced system that allows the operator to adjust (trim) the level of the machine to the left or right when the platform is completely lowered. Use the following instructions to adjust the level of the machine.

1. With the machine in the stowed position turn the power on, start machine.
2. Press the QuikLevel Advanced button on the front of the platform control station.
3. To adjust (trim) the machine to the right, activate the steer switch on the top of the controller to the right until the desired position is reached.
4. To adjust (trim) the machine to the left, activate the steer switch on the top of the controller to the left until the desired position is reached.

Note: Anytime the trim function is used there is a possibility that the machine may become out of level. At this time the machine will no longer lift but the machine can be lowered.

Note: The machine must be in the stowed position before the trim function is operable.

3.18 PARKING AND STOWING

Park and stow the machine as follows:

1. Drive the machine to a reasonably well-protected and well ventilated area.
2. Ensure the platform is fully lowered.
3. Position the emergency stop switch to the off position.
4. If necessary, cover the instruction placards, caution and warning decals so that they will be protected from hostile environment.
5. Chock at least two wheels when parking the machine for an extended period of time.
6. Turn the platform/off/ground control select switch to off and remove the key to disable the machine and prevent unauthorized use.

3.19 PLATFORM RAILS FOLD-DOWN PROCEDURE

WARNING

Only fold down the rails when the machine is in the stowed (platform fully lowered) position. Do not raise the platform with the rails folded down. The rails must be in the upright position and properly pinned when raising the platform.

WARNING

After the rails have been folded down, use extreme caution when exiting and entering the platform. Enter and exit platform only at the gate area and ladder provided.

WARNING

If driving machine with the platform control station from ground, do not hang the control box on any part of the machine while driving. Hold the control box and keep at least 3 ft (1 m) distance from machine.

1. Remove the platform control station from the rails and place on the platform floor.
2. Lift up and pull out front platform rails to release from latch. Fold in towards side rails.
3. Lift up inner side rails and fold down to floor.
4. Pull pins at rear rails. Lift up and fold down rear gate to floor.
5. Lift up outer side rails and fold down to floor.

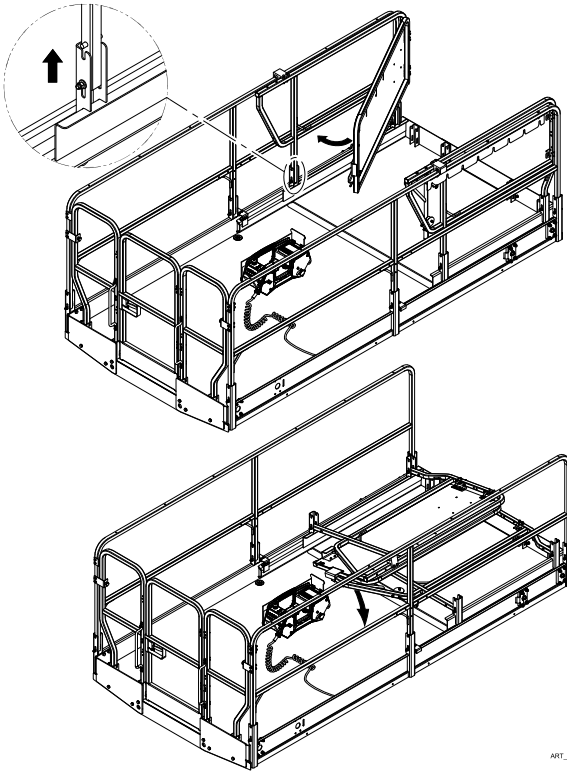

ART_04002780

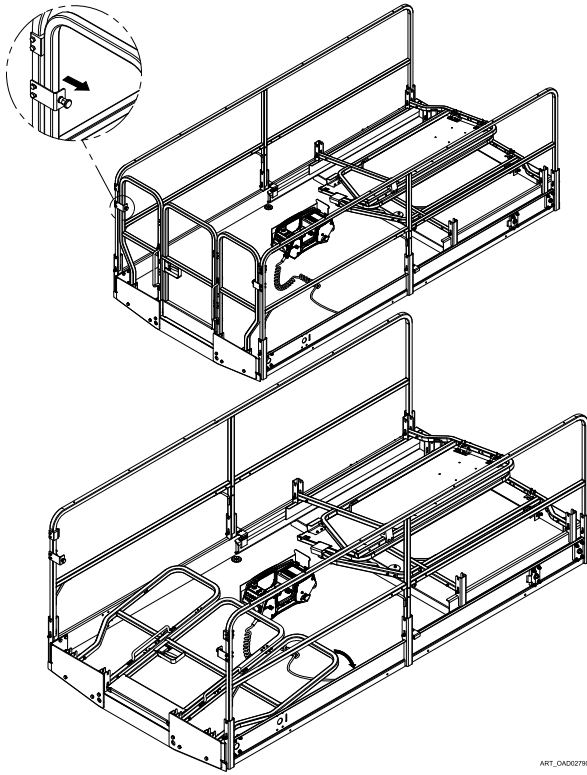

ART_D4002790

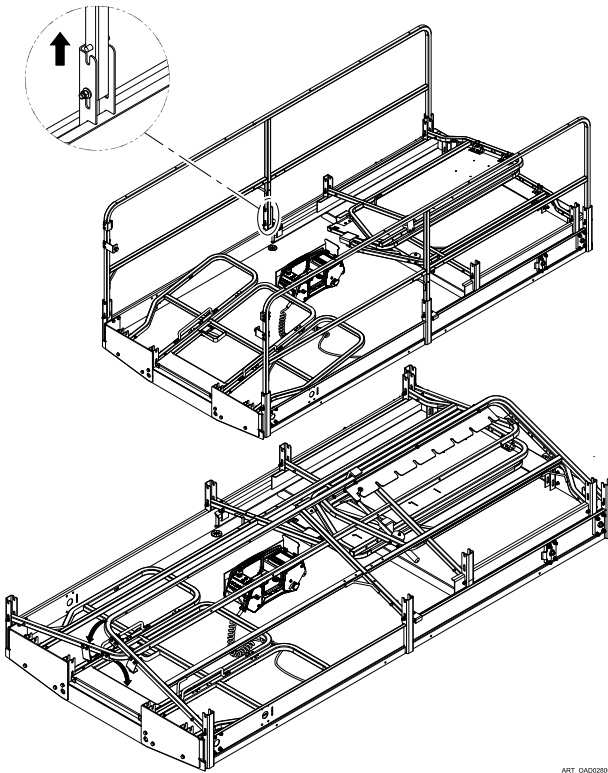

ART_DAO0200

3.20 MACHINE LIFTING AND TIE DOWN

3.20.1 Lifting

The machine may be lifted using a spreader bar and four equal length straps or chains capable of supporting the full gross weight of the machine (refer to section 6 for machine gross weight). Lift only using the four lift lugs provided at the four corners of the machine.

The machine may also be lifted using a forklift truck. Lift only using the built-in forklift pockets on the side of the machine, and only with the platform in the stowed position with extensions retracted. Adjust the width of the forklift tines to properly fit the machine's forklift pockets. Slide the forklift tines into the forklift pockets and carefully lift the machine.

3.20.2 Tie Down

When transporting the machine, the platform extension must be fully retracted and the platform fully lowered in the stowed mode with the machine securely tied down to the truck or trailer deck. Four tie down eyes, one at each corner of the machine frame, are provided for machine tie down.

3.21 TOWING

It is not recommended that this machine be towed, except in the event of an emergency such as a machine malfunction or a total machine power failure. Refer to [Section — Emergency Procedures](#) for emergency towing procedures.

3.22 LIFTING AND TIE DOWN CHART

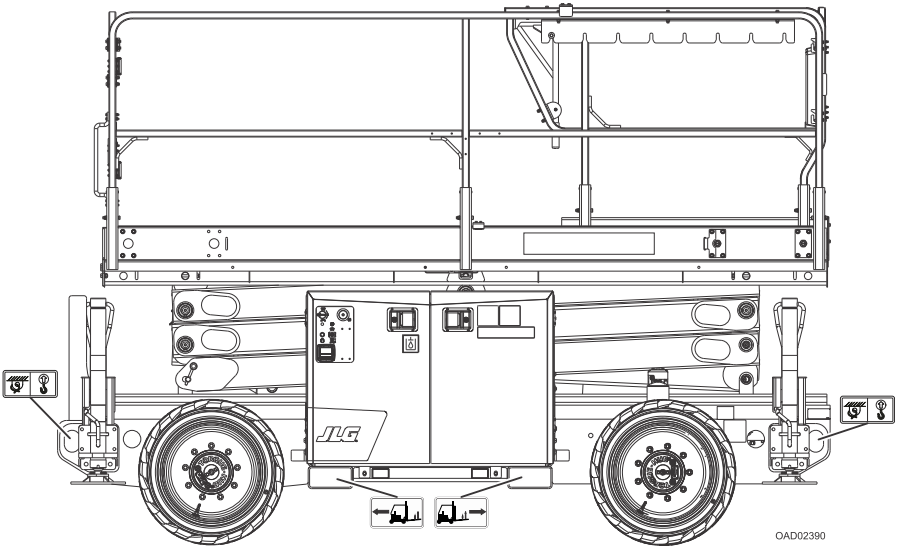

3.23 RT2669, RT3369 DECAL LOCATIONS

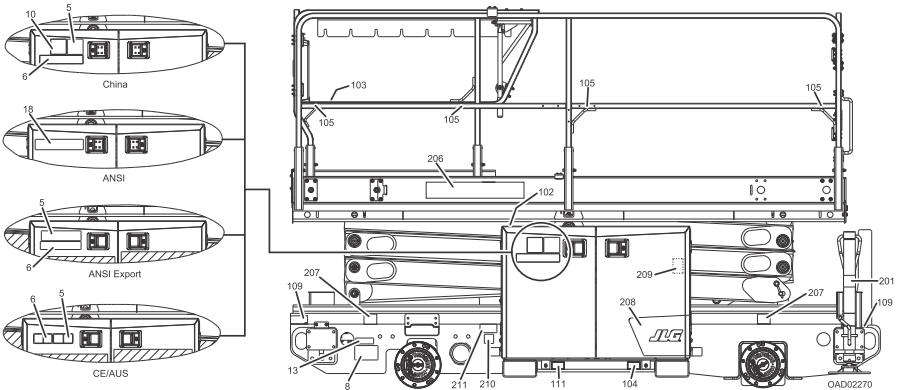

Figure 18. View 1

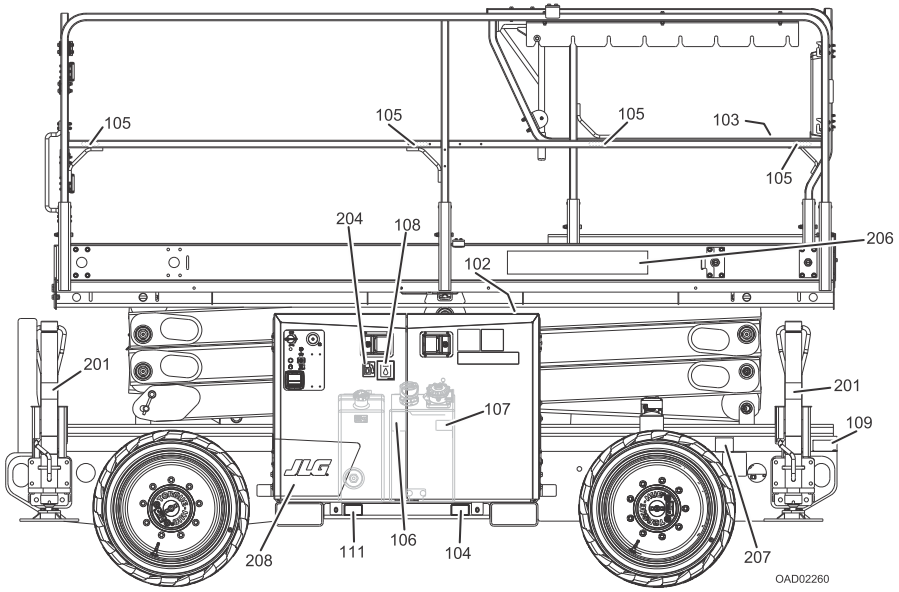

Figure 19. View 2

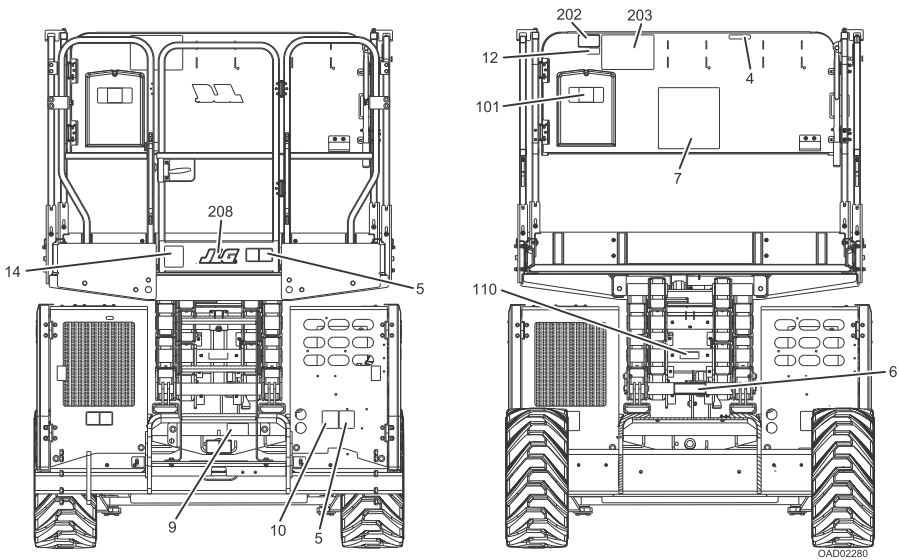

Figure 20. View 3

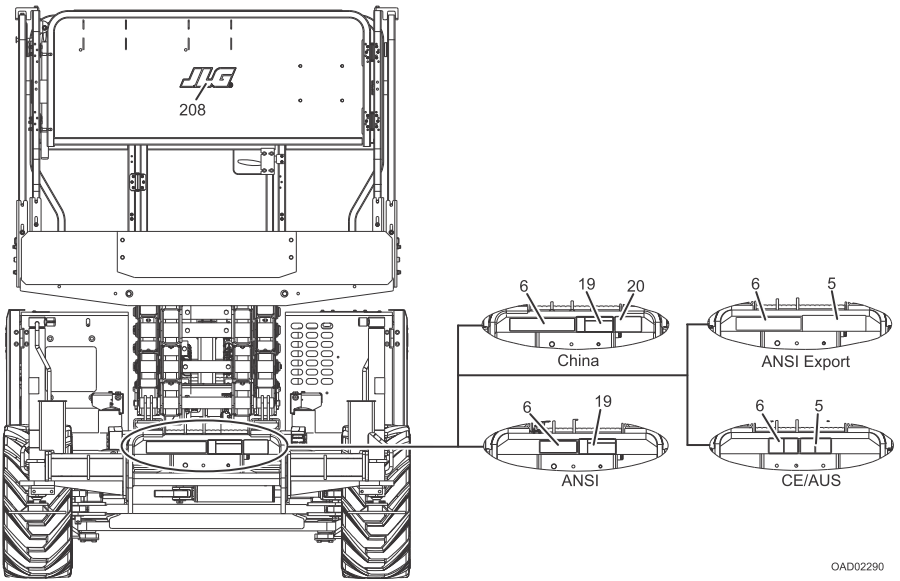

Figure 21. View 4

OAD02290

3.24 SAFETY DECAL LEGEND

Table 4. RT2669, RT3369 Decal Legend

Decal	ANSI/ANSI Export/CSA (1001256764-C)	English/Korean (1001256765-C)	English/Chinese (1001256766-C)	Spanish/Portuguese (1001256767-C)	English/Spanish (1001256768-C)	English/French (1001256769-C)	CE/UKCA/AUS (1001256770-D)
4	1703821	1001162112	1705194	1704702	1704694	1704687	—
5	1001211779	1001162114	1001211779	1705043	1705041	1705040	1705671
6	1001211777	1001215751	1001215752	1001216650	1001215754	1001215755	1705673
7	1703816	1001162115	1705195	1704699	1704691	1704684	—
8	1001223055	1001224048	1001224051	1001224052	1001224049	1001223971	—
9	1703822	1703822	1703822	1703822	1703822	1703822	1703822
10	—	—	1001215747	—	—	—	—
12	1001223453	—	—	—	—	1001223453	—
13	—	—	—	—	—	—	1705670
14	—	—	—	—	—	—	100129287
18	1703818	—	—	—	—	—	—
19	1705695	—	1705695	—	—	—	—
20	—	—	1705944	—	—	—	—
101	1701640	1701640	1701640	1701640	1701640	1701640	1701640
102	1703687	1703687	1703687	1703687	1703687	1703687	1703687
103	1703819	1703819	1703819	1703819	1703819	1703819	1703819
104	1001265579	1001265579	1001265579	1001265579	1001265579	1001265579	1001265579
105	1704277	1704277	1704277	1704277	1704277	1704277	1704277

Table 4. RT2669, RT3369 Decal Legend (continued)

Decal	ANSI/ANSI Export/CSA	English/Korean	English/Chinese	Spanish/Portuguese	English/Spanish	English/French	CE/UKCA/AUS
106	1704412	1704412	1704412	1704412	1704412	1704412	1704412
107	70046028	70046028	70046028	70046028	70046028	70046028	70046028
108	1001094708	1001094708	1001094708	1001094708	1001094708	1001094708	1001094708
109	1001162864	1001162864	1001162864	1001162864	1001162864	1001162864	1001162864
110	1001256865	1001256865	1001256865	1001256865	1001256865	1001256865	1001256865
111	1001265580	1001265580	1001265580	1001265580	1001265580	1001265580	1001265580
201	1701214	1001215447	1701214	1704698	1704697	1704690	1701785
202	1001231801	—	—	—	—	—	—
203 — RT2669	1001256793	1001256793	1001256793	1001256793	1001256793	1001256793	1001256793
203 — RT3369	1001256795	1001256795	1001256795	1001256795	1001256795	1001256795	1001256795
204 — Diesel	1701505	1701505	1701505	1701505	1701505	1701505	1701505
204 — Gas	1701542	1701542	1701542	1701542	1701542	1701542	1701542
206 — RT2669	1001256779	1001256779	1001256779	1001256779	1001256779	1001256779	1001256779
206 — RT3369	1001256780	1001256780	1001256780	1001256780	1001256780	1001256780	1001256780
207	1001256791	1001256791	1001256791	1001256791	1001256791	1001256791	1001256791

Table 4. RT2669, RT3369 Decal Legend (continued)

Decal	ANSI/ANSI Export/CSA	English/Korean	English/Chinese	Spanish/Portuguese	English/Spanish	English/French	CE/UKCA/AUS
208	1001263163	1001263163	1001263163	1001263163	1001263163	1001263163	1001263163
209	1704972	1706061	1706060	1706059	1706063	1706064	1706098
210	—	—	—	—	—	—	1001214029
211	1001143852	1001143852	1001143852	1001143852	1001143852	1001143852	1001143852

3.25 ERT2669, ERT3369 DECAL LOCATIONS

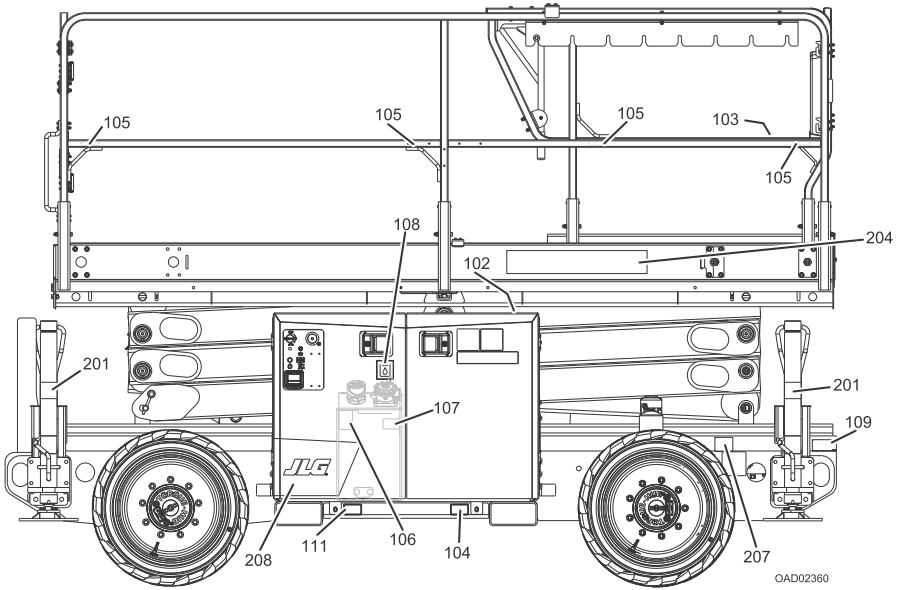

Figure 22. View 1

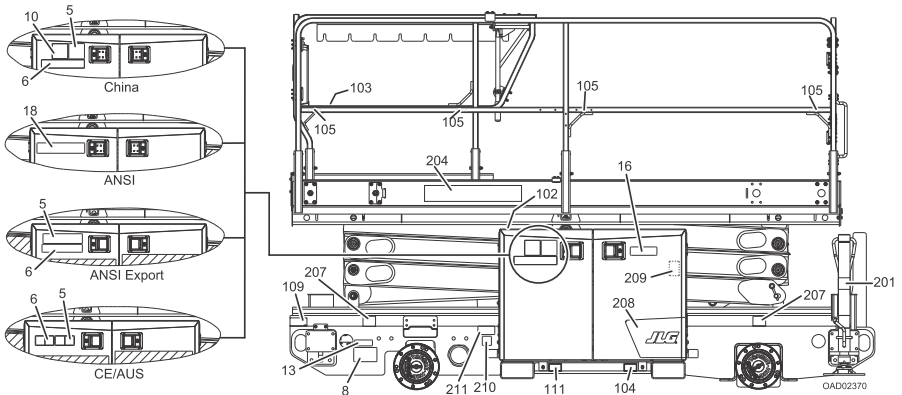
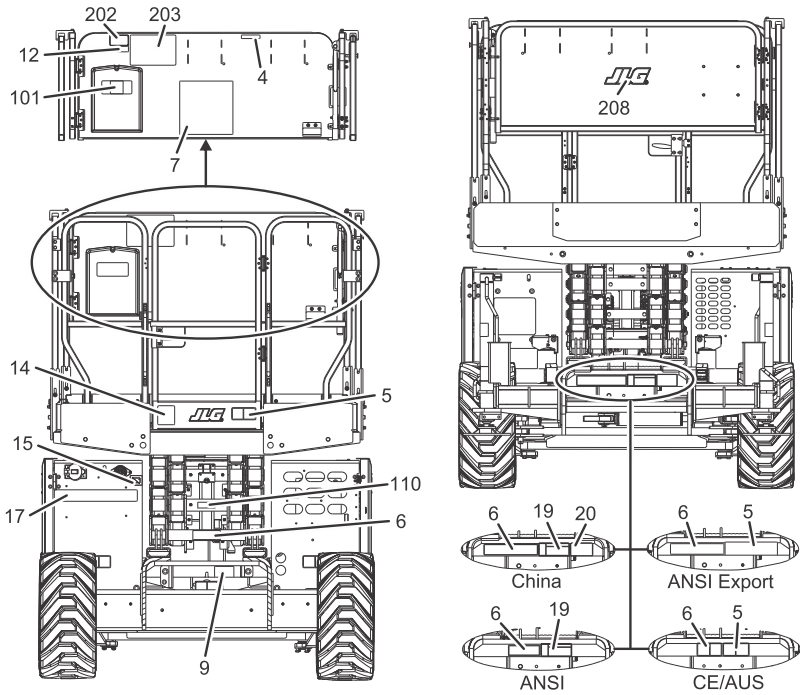

Figure 23. View Two



OAD02380

Table 5. ERT2669, ERT3369 Decal Legend

Decal	ANSI/ANSI Export/ CSA	English/Korean	English/Chinese	Spanish/ Portuguese	English/Spanish	English/French	CE/UKCA	AUS
	(1001256771-C)	(1001256772-C)	(1001256773-C)	(1001256774-C)	(1001256775-C)	(1001256776-C)	(1001256777-C)	(1001256778-C)
4	1703821	1001162112	1705194	1704702	1704694	1704687	—	—
5	1001211779	1001162114	1001211779	1705043	1705041	1705040	1705671	1705671
6	1001211777	1001215751	1001215752	1001216650	1001215754	1001215755	1705673	1705673
7	1703816	1001162115	1705195	1704699	1704691	1704684	—	—
8	1001223055	1001224048	1001224051	1001224052	1001224049	1001223971	—	—
9	1703822	1703822	1703822	1703822	1703822	1703822	1703822	1703822
10	—	—	1001215747	—	—	—	—	—
12	1001223453	—	—	—	—	1001223453	—	—
13	—	—	—	—	—	—	1705670	1705670
15	1702155	1702155	1702155	1702155	1702155	1702155	1702155	1702155
16	1703813	1707022	1704344	1704341	1704339	1704340	—	—
17	1001146794	1001146794	1001146794	1001146794	1001146794	1001146794	1001146794	1001146794
18	1703818	—	—	—	—	—	—	—
19	1705695	—	1705695	—	—	—	—	—
20	—	—	1705944	—	—	—	—	—
101	1701640	1701640	1701640	1701640	1701640	1701640	1701640	1701640
102	1703687	1703687	1703687	1703687	1703687	1703687	1703687	1703687

Table 5. ERT2669, ERT3369 Decal Legend (continued)

Decal	ANSI/ANSI Export/ CSA	English/Korean	English/Chinese	Spanish/ Portuguese	English/Spanish	English/French	CE/UKCA	AUS
103	1703819	1703819	1703819	1703819	1703819	1703819	1703819	1703819
104	1001265579	1001265579	1001265579	1001265579	1001265579	1001265579	1001265579	1001265579
105	1704277	1704277	1704277	1704277	1704277	1704277	1704277	1704277
106	1704412	1704412	1704412	1704412	1704412	1704412	1704412	1704412
107	70046028	70046028	70046028	70046028	70046028	70046028	70046028	70046028
108	1001094708	1001094708	1001094708	1001094708	1001094708	1001094708	1001094708	1001094708
109	1001162864	1001162864	1001162864	1001162864	1001162864	1001162864	1001162864	1001162864
110	1001256865	1001256865	1001256865	1001256865	1001256865	1001256865	1001256865	1001256865
111	1001265580	1001265580	1001265580	1001265580	1001265580	1001265580	1001265580	1001265580
201	1701214	1001215447	1701214	1704698	1704697	1704690	1701785	1701785
202	1001231801	—	—	—	—	—	—	—
203 — ERT2669	1001256793	1001256793	1001256793	1001256793	1001256793	1001256793	1001256793	1001256793
203 — ERT3369	1001256795	1001256795	1001256795	1001256795	1001256795	1001256795	1001256795	1001256795
204 — ERT2669	1001256783	1001256783	1001256783	1001256783	1001256783	1001256783	1001256783	1001256783
204 — ERT3369	1001256784	1001256784	1001256784	1001256784	1001256784	1001256784	1001256784	1001256784
207	1001256791	1001256791	1001256791	1001256791	1001256791	1001256791	1001256791	1001256791

Table 5. ERT2669, ERT3369 Decal Legend (continued)

Decal	ANSI/ANSI Export/ CSA	English/Korean	English/Chinese	Spanish/ Portuguese	English/Spanish	English/French	CE/UKCA	AUS
208	1001263163	1001263163	1001263163	1001263163	1001263163	1001263163	1001263163	1001263163
209	1704972	1706061	1706060	1706059	1706063	1706064	1706098	1706098
210	—	—	—	—	—	—	1001214029	—

This Page is intentionally left blank

This Page is intentionally left blank

SECTION 4

Emergency Procedures

4.1 GENERAL

This section explains the steps to be taken in case of an emergency situation during operation.

4.2 INCIDENT NOTIFICATION

JLG Industries, Inc. must be notified immediately of any incident involving a JLG product. Even if no injury or property damage is evident, JLG must be contacted by telephone and provided with all necessary details.

- USA: 877-JLG-SAFE (554-7233)
- EUROPE: (32) 0 89 84 82 20
- AUSTRALIA: (61) 2 65 811111
- E-mail: productsafety@jlg.com

Failure to notify the manufacturer of an incident involving a JLG Industries product within 48 hours of such an occurrence may void any warranty consideration on that particular machine.

NOTICE

Following any incident, thoroughly inspect the machine. Do not elevate the platform until it is certain that all damage has been repaired and that all controls are operating correctly. Test all functions first from the ground control station then from the platform control console.

4.3 EMERGENCY OPERATION

4.3.1 Use of Ground Controls

NOTICE

Know how to use the ground controls in an emergency situation.

Ground personnel must be thoroughly familiar with the machine operating characteristics and the ground control functions. Training should include operation of the machine, review and understanding of this section and hands-on operation of the controls in simulated emergencies.

4.3.2 Operator Unable to Control Machine

If the platform operator is unable to operate or control the machine:

1. Other personnel should operate the machine from ground controls only as required.
2. Only qualified personnel on the platform may use the platform controls. DO NOT CONTINUE OPERATION IF CONTROLS DO NOT FUNCTION NORMALLY.
3. Rescue equipment can be used to remove the platform occupant(s). Cranes and forklifts can be used to stabilize motion of the machine.

4.3.3 Platform Caught Overhead

If the platform becomes jammed or snagged in overhead structures or equipment, do the following:

1. Shut off the machine.
2. Rescue all people in the platform before freeing the machine. Personnel must be out of the platform before operating any controls on the machine.
3. Use cranes, forklifts or other equipment to stabilize motion of the machine to prevent a tip over as required.
4. From the ground controls, carefully free the platform from the object.
5. Once clear, restart the machine and return the platform to a safe position.
6. Inspect the machine for damage. If the machine is damaged or does not operate properly, turn off the machine immediately. Report the problem to the proper maintenance personnel. Do not operate the machine until it is declared safe for operation.

4.3.4 Righting of Tipped Machine

A fork truck of suitable capacity or equivalent equipment should be placed under the elevated side of the chassis, with a crane or other suitable lifting equipment used to lift the platform while the chassis is lowered by the forklift or other equipment.

4.4 PLATFORM MANUAL DESCENT CONTROL

The platform manual descent control is used in the event of total power failure to lower the platform using gravity. The red T-handle is located at the rear of the machine behind the ladder. Look for the instruction decal located beside the handle.

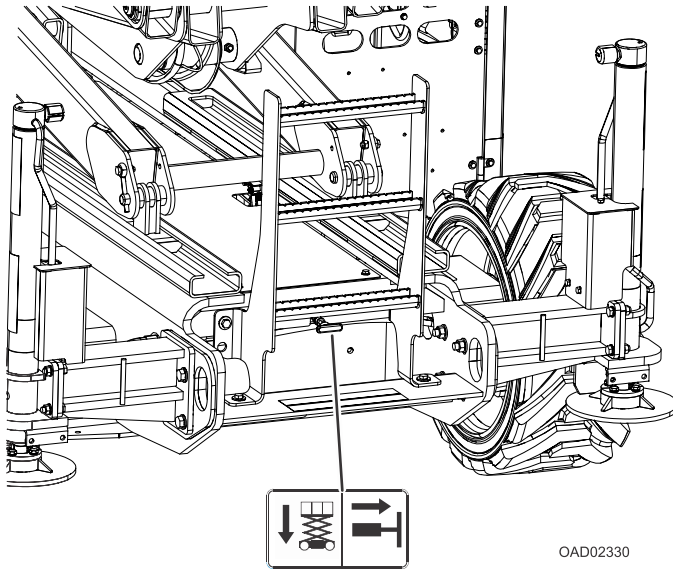

OAD02330

1. Locate the red platform manual descent control T-handle.

⚠ WARNING

Keep hands and arms out of the path of the scissor arms and platform while lowering.

2. Grasp the T-handle and slowly pull out to lower the scissor arms/platform. When the platform is lowered to the desired level, release the T-handle.

4.5 EMERGENCY TOWING PROCEDURES

Towing this machine is prohibited, unless properly equipped. However, provisions have been incorporated to move the machine in case of a malfunction or power failure. The following procedures are to be used **ONLY** for emergency movement to a suitable maintenance area.

4.5.1 RT Machines

1. Ensure the machine is in the stowed position. Chock wheels securely.
2. Disengage drive hubs by reversing disconnect caps.
3. Connect suitable equipment, remove chocks, and move machine.

4. After moving machine, complete the following procedures:
 - Position machine on a firm and level surface.
 - Chock wheels securely.
 - Engage drive hubs by reversing disconnect caps on hubs.
 - Remove chocks from wheels as needed.

4.5.2 ERT Machines

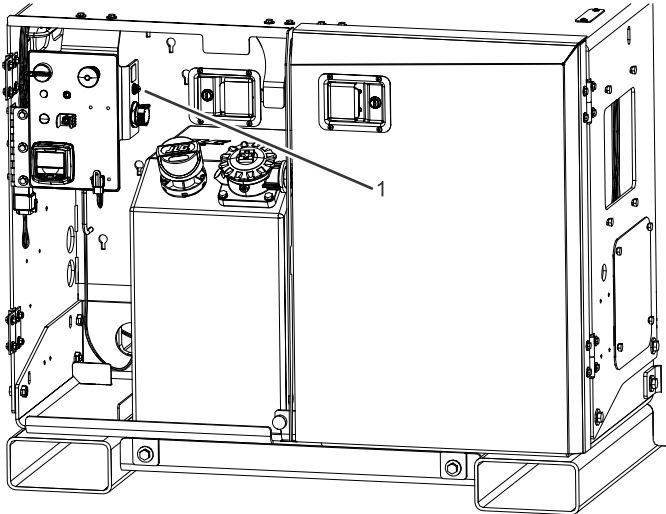

OAD02490

1. Electric Brake Release Button

1. Ensure the machine is in the stowed position. Chock wheels securely. Connect machine to suitable towing equipment.
2. Pull out the emergency stop switch and position the keyswitch to ground mode.
3. Look for the yellow button (**1**) inside the hydraulic compartment on the side of the ground control panel. Press and hold for at least one second. Once released, the alarm will sound.
4. Remove chocks and tow machine.
5. After towing is complete, chock the wheels.
6. To reset the brakes, push the yellow button again, recycle power to the machine, or position the keyswitch to platform mode.

This Page is intentionally left blank

This Page is intentionally left blank

SECTION 5

Accessories

5.1 AVAILABLE ACCESSORIES

Table 6. Available Accessories

ACCESSORY	Market						
	ANSI (USA Only)	ANSI	CSA	Korea	CE/ UKCA	China	AUS
Footswitch				✓			
Generator (2500W) **	✓	✓	✓	✓	✓	✓	✓
Onboard Generator (3500W) *	✓	✓	✓	✓	✓	✓	✓
Panel Carrier	✓	✓	✓	✓	✓	✓	✓
Pipe Racks	✓	✓	✓	✓	✓	✓	✓
Platform Extension Handle	✓	✓	✓	✓	✓	✓	✓
Platform Worklights	✓	✓	✓	✓	✓	✓	✓
Workstation	✓	✓	✓	✓	✓	✓	✓

* This accessory is not available for RT2669 or ERT2669 machines.

** This accessory is not available for ERT machines.

Table 7. Options/Accessories Relationship Table

Accessory	Compatible With (Note 1)	Incompatible With
Footswitch	All	–
Generator (2500W)	Footswitch, Panel Carrier, Pipe Racks, Platform Extension Handle, Platform Worklights, Workstation	Onboard Generator (3500W)
Onboard Generator (3500W)	Footswitch, Panel Carrier, Pipe Racks, Platform Extension Handle, Platform Worklights, Workstation	2500W Generator, ERT Genset
Panel Carrier	Footswitch, Platform Extension Handle, Platform Worklights, Generator (2500W), Onboard Generator (3500W)	Pipe Racks, Work Station

Table 7. Options/Accessories Relationship Table (continued)

Accessory	Compatible With (Note 1)	Incompatible With
Pipe Racks	Footswitch, Platform Extension Handle, Platform Worklights, Generator (2500W), Onboard Generator (3500W)	Panel Carrier, Workstation
Platform Extension Handle	All	–
Platform Worklights	All	–
Workstation	Footswitch, Platform Extension Handle, Platform Worklights, Generator (2500W), Onboard Generator (3500W)	Panel Carrier, Pipe Racks
Note 1: Any accessory not listed under "COMPATIBLE WITH" is assumed to be incompatible.		

5.2 FOOTSWITCH

The Footswitch serves as another enable switch in the function control circuit. It must be depressed in sequence with the platform control joystick trigger switch to enable operation of machine functions when using the platform controls. Power is removed from the platform controls when the footswitch is released.

Note: This accessory is only available in Korean markets.

5.2.1 Operation

To operate a function, engage the footswitch and joystick trigger in any sequence before operating a function.

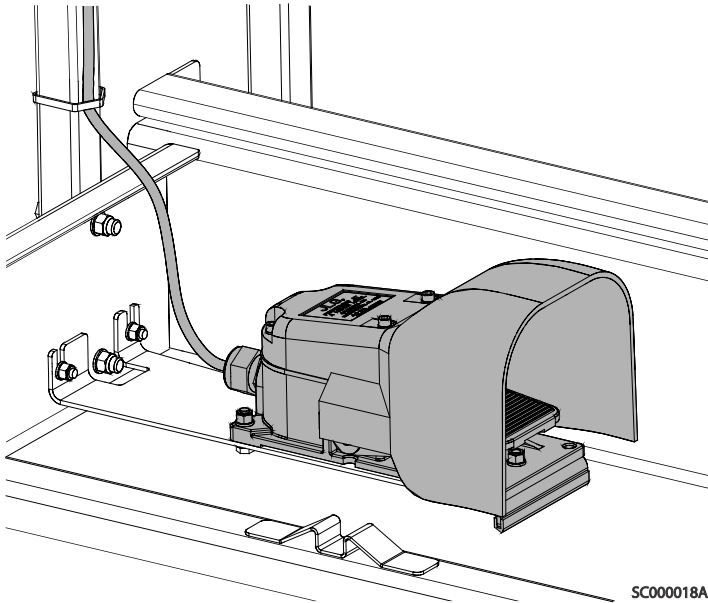

Figure 25. Footswitch Assembly

5.3 GENERATOR (2500W)

The generator (2500W) supplies AC power from the engine compartment to an AC receptacle in the platform and to an outlet box in the engine compartment above the hydraulic pump..

The generator is activated by a switch on the platform control box.

Output

- 110 V, 60 Hz
- 110 V, 50 Hz (CE/UKCA, GB, AUS Markets Only)

Safety Precautions

⚠ WARNING

Do not overload platform.

- Ensure no personnel are beneath platform.
- Keep lanyard attached at all times.
- Do not use electrical tools in water.
- Use correct voltage and frequency for tool being used.

- Do not overload circuit (generator is equipped with a thermal 20 amp circuit breaker).

Preparation and Inspection

- Ensure generator is secure.
- Check condition of belt, belt tension, and wiring.

Operation

Start the engine, then turn on the generator.

5.4 ONBOARD GENERATOR (3500W)

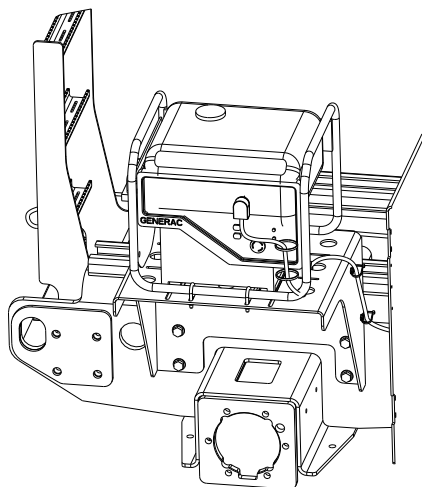

An optional gasoline-powered generator mounted to the chassis provides power for tools and other items at ground level.

5.4.1 Generator Specifications

- AC Rated Output running: 3000W
- Fuel Tank (Gasoline): 2.37 gal (9L)
- Run time at 50% of rated load: 8 hr
- Run time at 25% of rated load: 11 hr

5.4.2 Safety Precautions

- Do not use electrical tools in water.
- Use correct voltage and frequency for tool being used.
- Do not overload circuit.

5.4.3 Preparation and Inspection

- Ensure generator is secure.
- Check condition of generator components and wiring.

5.4.4 Operation

Start the generator, then plug in tools or items to be used.

5.5 PANEL CARRIER

The Panel Carrier can transport flat sheets or panels to an elevated site by positioning them in a channel on the outside of the platform. It consists of a carrier tray that runs parallel to the length of the platform and an adjustable bracket mounted to the handrail to hold material in place.

The panels can measure up to 4 ft x 8 ft (1.22 m x 2.4 m), or approximately 32 sq. (3 m sq.).

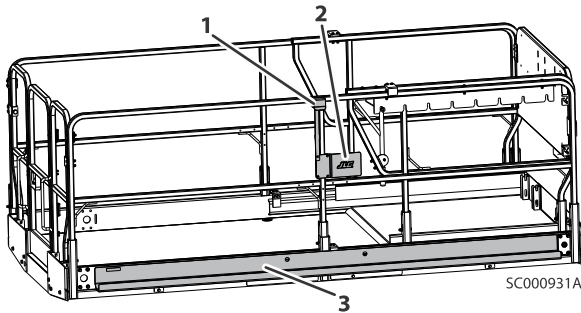

1. Adjustable Bracket

2. Capacity Decal (on back)

3. Carrier Tray

5.5.1 Safety Precautions

⚠ WARNING

This accessory affects the overall platform capacity. Refer to the capacity decal and adjust accordingly.

WARNING

When the carrier tray is loaded, the increase of area exposed to wind will decrease stability. Refer to the decal for maximum manual side force, wind speed, and capacity limit.

- Ensure no personnel are beneath the platform.
- Do not exit the platform over the rails, or stand on the rails.
- Remove the tray when not in use.

5.5.2 Preparation and Inspection

- Ensure all components are secured to the platform.
- Check for any missing or damaged components. Replace if necessary.
- Check for loose nuts and bolts. If necessary, torque according to the Torque Chart specifications in the Service Manual.
- Replace any missing or illegible decals.

5.5.3 Operation

1. Load the Panel Carrier with material and secure with the adjustable bracket.
2. Position the panel to its desired location.
3. Carefully unload panel. Secure the adjustable bracket before continuing machine operation.

5.6 PIPE RACKS

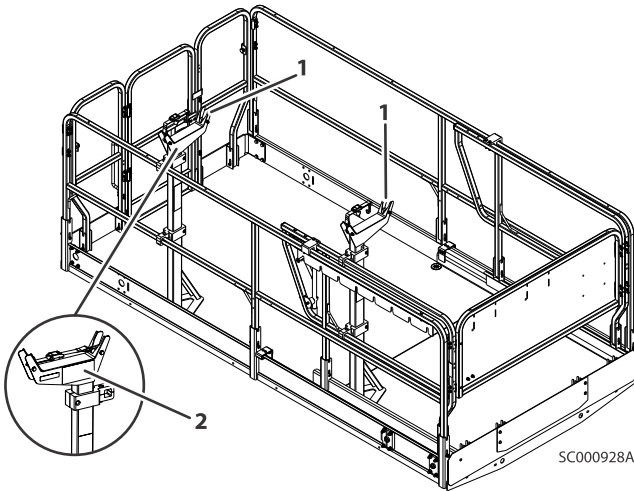

1. Adjustable Strap and Hook

2. Capacity Decal

Pipe Racks store pipe or conduit inside the platform in order to prevent rail damage and optimize platform utility. This accessory consists of two racks mounted to the platform floor with adjustable straps and hooks to secure the load in place.

5.6.1 Safety Precautions

⚠ WARNING

This accessory affects overall platform capacity. Refer to capacity decal and adjust accordingly. Weight in racks plus weight in platform must not exceed rated capacity.

RT2669 ERT2669 MAX. = 680kg/ 1500 lb				RT2669 ERT2669 MAX. = 680kg/ 1500 lb	
RT3369 ERT3369 MAX. = 454kg/ 1000 lb				RT3369 ERT3369 MAX. = 454kg/ 1000 lb	
RT4069 ERT4069 MAX. = 363kg/ 800 lb				RT4069 ERT4069 MAX. = 363kg/ 800 lb	

SC000037A

NOTICE

Retract platform extension before loading material.

- Ensure no personnel are beneath the platform.
- Do not exit platform over rails, or stand on rails.
- Do not drive machine without material secured.

5.6.2 Preparation and Inspection

- Ensure racks are secured to the platform floor. Torque loose nuts or bolts as required
- Check for missing or damaged components. Replace if necessary

5.6.3 Operation

1. Place material onto racks with weight evenly distributed between both racks.
2. Route the tie-down straps at each end across loaded material. Hook into place and tighten until secure.
3. To remove material, loosen and unhook tie-down straps, then carefully remove material from racks.

Note: Reinstall straps across any remaining material before continuing machine operations.

5.7 PLATFORM EXTENSION HANDLE

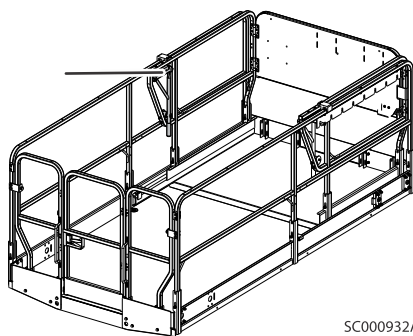

A second platform extension handle mounted in the platform will aid in the operation of the extension deck.

5.8 PLATFORM WORKLIGHTS

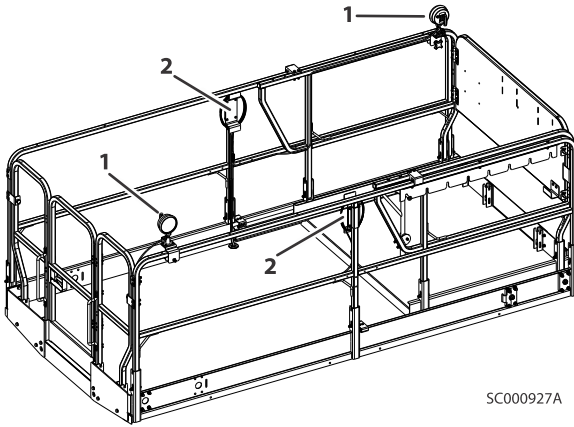

1. Platform Worklights

2. Bracket for excess cable

The Platform Worklights accessory consists of two 12V lights mounted to the platform railings. These lights can be moved around the platform as needed. Use the bracket to coil any excess cable.

5.9 WORKSTATION

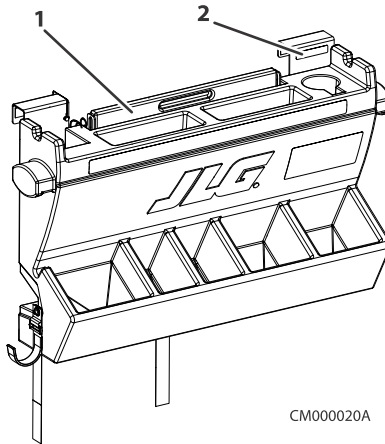

1. Adjustable Work Surface

2. Accessory Decal

The Workstation offers an adjustable work surface and additional space for storage of tools and objects.

Note: Workstation may be attached to handrails anywhere in platform unless machine is equipped with another accessory or option. If another accessory or option is present, Workstation must be located on opposite side of platform.

5.9.1 Safety Precautions

WARNING

This accessory affects the platform capacity. Refer to the capacity decal and adjust accordingly. Do not overload the platform.

- Return the adjustable work surface to the stowed position when finished working.
- Do not drive the machine unless materials are properly secured or stored.

5.9.2 Preparation and Inspection

- Ensure the Workstation is secured to the platform.
- Check for missing or damaged components. Replace if necessary.
- Check for loose nuts and bolts. Torque to JLG Torque Chart Specifications if necessary.
- Replace any missing or illegible decals.

5.9.3 Operation

To use the adjustable work surface, lift the handle and position across the Workstation.

This Page is intentionally left blank

This Page is intentionally left blank

SECTION 6

Machine Specifications and Operator Maintenance

6.1 GENERAL

This section of the manual provides additional necessary information to the operator for proper operation and maintenance of this machine.

The maintenance portion of this section is intended as information to assist the machine operator to perform daily maintenance tasks only and does not replace the more thorough Preventive Maintenance and Inspection Schedule included in the Service & Maintenance Manual.

6.2 OTHER PUBLICATIONS AVAILABLE

Service & Maintenance Manual	31220313
Illustrated Parts Manual	RT Machines — 31220314 ERT Machines — 31220315

6.2.1

6.3 MACHINE SPECIFICATIONS

6.3.1 Operating Specifications

Specification	Model			
	RT2669	ERT2669	RT3369	ERT3369
Maximum Platform Height	26 ft (8 m)	26 ft (8 m)	33 ft (10 m)	33 ft (10 m)
Gross Machine Weight				
Single Oscillating Axle	8,090 lb (3670 kg)	8,250 lb (3742 kg)	9,080 lb (4119 kg)	9,425 lb (4275 kg)
Dual Oscillating Axle	8,340 lb (3783 kg)	—	9,330 lb (4232 kg)	—
Dual Oscillating Axle (CE/UKCA Only)	—	—	9,540 lb (4286 kg)	—

Machine Specifications and Operator Maintenance

Specification	Model			
	RT2669	ERT2669	RT3369	ERT3369
Maximum Stowed Travel Grade (Gradeability)	40% (22°)	40% (22°)	35% (19°)	35% (19°)
Maximum Stowed Travel Grade (Side Slope)	5°	5°	5°	5°
Maximum Tire Load	3,600 lb (1633 kg)	3,600 lb (1633 kg)	3,600 lb (1633 kg)	3,600 lb (1633 kg)
Maximum Ground Bearing Pressure	40 psi	40 psi	40 psi	40 psi
Turning Radius				
Inside	83 in (211 cm)	83 in (211 cm)	83 in (211 cm)	83 in (211 cm)
Outside	175 in (444 cm)	175 in (444 cm)	175 in (444 cm)	175 in (444 cm)
Drive Speed				
High Drive Speed (Rabbit)				
4WD	3.4 mph (5.6 kph)	—	3.4 mph (5.6 kph)	—
2WD	3.3 mph (5.3 kph)	3.5 mph (5.6 kph)	3.3 mph (5.6 kph)	3.5 mph (5.3 kph)
Low Drive Speed (Turtle)				
4WD	1.7 mph (2.7 kph)	—	1.7 mph (2.7 kph)	—
2WD	1 mph (1.6 mph)	1 mph (1.6 mph)	1 mph (1.6 mph)	1 mph (1.6 mph)
Elevated Drive Speed	0.5 mph (0.8 kph)	0.5 mph (0.8 kph)	0.5 mph (0.8 kph)	0.5 mph (0.8 kph)
High Drive Speed Cutout Height	70 in (1.78 m)	70 in (1.78 m)	80 in (2.03 m)	80 in (2.03 m)
Platform Lift Up Time (Rated Load)	24 — 32 sec	29 — 37 sec	32 — 40 sec	36 — 44 sec
Platform Lift Down Time (Rated Load)	29 — 37 sec	29 — 37 sec	32 — 40 sec	32 — 40 sec
Hydraulic Pressures				
Main Relief	3800 psi	2700 psi	3800 psi	2750 psi
Steer Relief (Right)	2500 psi	2500 psi	2500 psi	2500 psi
Steer Relief (Left)	1900 psi	1900 psi	1900 psi	1900 psi

Specification	Model			
	RT2669	ERT2669	RT3369	ERT3369
Lift Relief	2750 psi	—	2750 psi	—
Electrical System Voltage	12 V	48 V	12 V	48 V
Ground Clearance	9.5 in (24.1 cm)	9.5 in (24.1 cm)	9.5 in (24.1 cm)	9.5 in (24.1 cm)
Breakover Angle	30° (57.7%)	30° (57.7%)	30° (57.7%)	30° (57.7%)
Electronic Arm Guards Pause Height (CE Only)	90 in (229 cm)	90 in (229 cm)	90 in (229 cm)	90 in (229 cm)

6.3.2 Dimensions

Dimension	Measurement
Stowed Height	RT2669, ERT2669 96.7 in (2456 mm)
	RT3369, ERT3369 102.91 in (2614 mm)
Machine Length	Extension Retracted 139 in (3530 mm)
	Extension Deployed 170.9 in (4340 mm)
Machine Width	69.3 in (1760 mm)
Wheelbase	81.3 in (2065 mm)

6.3.3 Maximum Allowable Operating Slope

Model	Lift Up and Drive prevented when elevated and tilted Front to Back beyond the following limits:	Lift Up and Drive prevented when elevated and tilted Side to Side beyond the following limits:
RT2669, ERT2669	3°	4° at 0% — 55% Capacity
		3° at 56% — 75% Capacity
		2.5° at 76% — 100% Capacity
RT3369, ERT3369	3°	3.5° at 0% — 35% Capacity
		3.0° at 36% — 55% Capacity
		2.5° at 56% — 100% Capacity

6.3.4 Platform Capacity

Note: INDOOR USE is use of a MEWP in areas shielded from wind so that there is no wind. OUTDOOR USE is use of a MEWP in an environment that can be exposed to wind.

Specification	Model			
	RT2669	ERT2669	RT3369	ERT3369
Maximum Occupants				
Indoor	4	4	4	4
Outdoor	4	4	2	2
Maximum Platform Capacity	1,500 lb (681 kg)	1,500 lb (681 kg)	1,000 lb (454 kg)	1,000 lb (454 kg)
Deck Extension Capacity	300 lb (136 kg)	300 lb (136 kg)	300 lb (136 kg)	300 lb (136 kg)
Maximum Allowable Wind Speed				
Indoor	0 mph (0 m/s)	0 mph (0 m/s)	0 mph (0 m/s)	0 mph (0 m/s)
Outdoor	28 mph (12.5 m/s)	28 mph (12.5 m/s)	28 mph (12.5 m/s)	28 mph (12.5 m/s)
Maximum Horizontal Side Force	90 lb (400 N)	90 lb (400 N)	90 lb (400 N)	90 lb (400 N)

6.3.5 Fluid Capacities

Specification	RT2669, RT3369
Fuel Tank	
Diesel	10 gal (38 L)
Gasoline	10 gal (38 L)
LPG Tank	33.5 lb (15.2 kg)
Hydraulic Tank	13.2 gal (50 L)
Engine Oil	
Diesel	6 qt (5.7 L)
Dual Fuel	3.6 qt (3.4 L)
Engine Coolant	4.44 qt (4.2 L)
Drive Brake (Each) (2WD Only)	2.7 oz (0.08 L)

Machine Specifications and Operator Maintenance

Specification	RT2669, RT3369
Drive Hub (Each)	
2WD	17 oz (0.5 L)
4WD	18.3 oz (0.54 L)

Specification	ERT2669, ERT3369
Drive Hub (Each)	18.26 oz (0.54 L)
Hydraulic Tank	10.6 gal (40 L)

6.3.6 Batteries (ERT Machine)

Specification	Battery	
Voltage		
Total Per Battery	48 V 6 V	48 V 6 V
Amp Hour Rating	310 Ah @ 20 hr	225 Ah @ 20 hr
Reserve Capacity	675 minutes	447 minutes

6.3.7 Tires

Specification	All Models
Size	26 x 12 D460 Foam-Filled
Ply Rating	10
Inflation Pressure	70 psi (4.8 bar)
Wheel Nut Torque	105 ft. lb. (230.5 Nm)

6.3.8 Battery Charger (ERT Machines)

Battery Charger Type	Delta-Q
Electrical System Voltage (DC)	48 V (1200 W)
Input	
AC Input Voltage	85 VAC to 270 VAC
Nominal AC Input Voltage	120 VAC to 240 VAC
Input Frequency	50 Hz to 60 Hz
Max. AC Input Current	14.5A
Ingress Protection	IP66
Operating Temperature	-40°F to 149°F (-40°C to 65°C)
Storage Temperature	-40°F to 185°F (-40°C to 85°C)

<p>Output</p> <p>Nominal DC Output Voltage Max. DC Output Voltage Max DC Output Current Derated</p> <p>Protection</p> <p>Output Reverse Polarity Output Short Circuit AC Overload DC Overload</p>	<p>48 V 72 V 20A > 104° (40°F)</p> <p>Electronic Protection-Auto Reset Current Limited Current Limited Current Limited</p>
---	---

6.4 ENGINE SPECIFICATIONS

Kubota Diesel (D1305-E4B)					
Emissions	CARB, EPA Tier 4 Final, EU Stage V, China III				
Fuel Type	Diesel: - Low Sulfur (<500 ppm) - Ultra Low Sulfur (15 ppm) (Required to meet EPA Tier 4 Final, EU Stage V) - Up to 5% biodiesel				
Number of Cylinders	3				
Engine RPM Control	Engine Control Unit (ECU)				
Low RPM Set	1400 RPM				
High RPM Set	2600 RPM				
Alternator	40 Amp, 12V, Belt-Driven				
Battery	69 Amp-Hour, 700 Cold-Cranking Amps, 12V DC				
Fuel Consumption	<table style="width: 100%; border: none;"> <tr> <td style="text-align: right; padding-right: 20px;">Low RPM</td> <td>0.41 gal/hr (1.5 L/hr)</td> </tr> <tr> <td style="text-align: right; padding-right: 20px;">High RPM</td> <td>2.0 gal/hr (7.6 L/hr)</td> </tr> </table>	Low RPM	0.41 gal/hr (1.5 L/hr)	High RPM	2.0 gal/hr (7.6 L/hr)
Low RPM	0.41 gal/hr (1.5 L/hr)				
High RPM	2.0 gal/hr (7.6 L/hr)				
Displacement	1.261 L (77 cu. in.)				
Gross Power	24.8 Hp (18.5 kW) @ 2600 RPM				
Gross Torque	59.1 ft. lb. (80.1 Nm) @ 1700 RPM				

Kubota Dual Fuel (WG972-GL-E4)	
Emissions	CARB, EPA Phase 3

Machine Specifications and Operator Maintenance

Fuel Type	Gasoline — 87 Octane minimum - Ethanol/Gas Mix — 10% maximum - Methanol/Gas Mix — 5% maximum - LP (Liquid Petroleum)
Number of Cylinders	3
Engine RPM Control	Engine Control Unit (ECU)
Low RPM Set	1400 RPM
High RPM Set	3500 RPM
Alternator	40 Amp, 12V, Belt-Driven
Battery	69 Amp-Hour, 700 Cold-Cranking Amps, 12V DC
Fuel Consumption (Gas)	
Low RPM	0.38 gal/hr (1.45 L/hr)
High RPM	1.76 gal/hr (6.66 L/hr)
Fuel Consumption (LP)	
Low RPM	1.85 lb/hr (0.84 kg/hr)
High RPM	9.3 lb/hr (4.23 kg/hr)
Displacement	0.962 L (58.7 cu. in.)
Gross Power	Gas — 31.1 Hp (23.2 kW) @ 3600 RPM LP — 29.5 Hp (22.0 kW) @ 3600 RPM
Gross Torque	Gas — 49.1 ft. lb.(66.6 Nm) @ 2400 RPM LP — 48.8 ft. lb. (66.2 Nm) @ 1800 RPM

6.5 ENGINE OIL OPERATING TEMPERATURE

NOTICE

Machine operation using non-JLG approved engine oil or operation outside of the temperature boundaries outlined in the “Engine Oil Operating Temperature” charts may result in premature wear or damage to components of the engine.

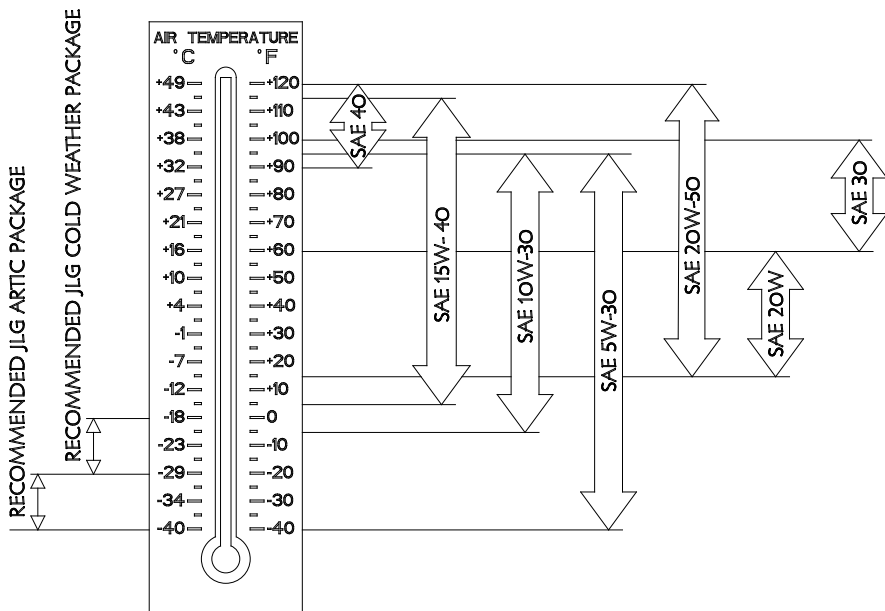

SC000501B

Figure 26. Kubota — Diesel (D1305-E4B)

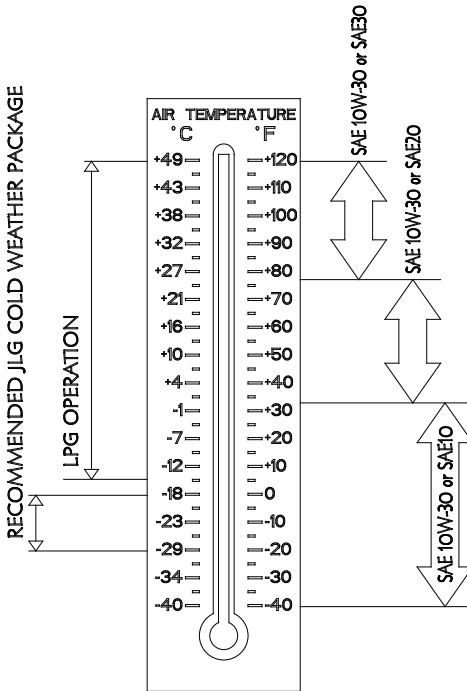

SC000500B

Figure 27. Kubota — Dual Fuel (WG972–GL-E4)

6.6 LUBRICATION

Note: Lubricate like items on each side of the machine.

Note: Recommended lubricating intervals are based on machine operations under normal conditions. For machines used in multi-shift operations and/or exposed to hostile environments or conditions, lubrication frequencies must be increased accordingly.

Operate hydraulic functions through one complete cycle before checking hydraulic oil level in tank. Oil should be visible in the ADD sight window on hydraulic tank. If oil is not visible, add oil until it is visible in both ADD and Full sight windows on tank. Do not overfill tank.

Table 8. Lubrication Specifications

KEY	SPECIFICATIONS
MPG	Multipurpose Grease having a minimum dripping point of 350° F. Excellent water resistance and adhesive qualities, and being of extreme pressure type. (Timken OK40 pounds minimum.)
EPGL	Extreme Pressure Gear Lube (oil) meeting API service classification GL-5 or MIL-Spec MIL-L-2105.

Table 8. Lubrication Specifications (continued)

KEY	SPECIFICATIONS
EO	Engine (crankcase) Oil. Gas — API SF/SG class, MIL-L2104. Diesel — API CC/CD class, MIL-L-2104B/MIL-L-2104C.
HO	Hydraulic Oil. API Service Classification GL-3.

Table 9. Hydraulic Oil SAE Viscosity Grade Operating Temperature Ranges

Hydraulic System Operating Temperature Range	SAE Viscosity Grade
+0° to + 180° F (-18° to +83° C)	10W
+0° to + 210° F (-18° to + 99° C)	10W-20, 10W-30
+50° to + 210° F (+10° to + 99° C)	20W-20

Note: Hydraulic oils must have anti-wear qualities of at least API Service Classification GL-3, and sufficient chemical stability for mobile hydraulic system service. JLG Industries recommends the use of standard UTTO.

Note: Machines may be equipped with biodegradable and non-toxic hydraulic oil. This is a fully synthetic hydraulic oil that possesses the same anti-wear and rust protection characteristics as mineral oils, but will not adversely affect the ground water or the environment when spilled or leaked in small amounts.

Note: Aside from JLG recommendations, it is not advisable to mix oils of different brands or types, as they may not contain the same required additives or be of comparable viscosities. If use of hydraulic oil other than standard UTTO is desired, contact JLG Industries for proper recommendations.

Note: When temperatures remain consistently below 20° F (-7° C), JLG Industries recommends the use of a premium cold weather hydraulic fluid (viscosity grade 32).

Table 10. Hydraulic Oil Properties and Classifications

Fluid	Properties		Base				Classifications		
	Viscosity at 40° C *	Viscosity Index	Mineral Oils	Vegetable Oils	Synthetic	Synthetic Polyol Esters	Readily Biodegradable**	Virtually Non-toxic †	Fire Resistant ‡
Shell Spirax S4 TXM — Recommended	67	146	X						
Mobilfluid 424 — <i>Optional</i>	60	134	X						
Shell Tellus S2 VX32 — Recommended	32	142	X						
Mobil DTE 10 Excel 32 — <i>Optional</i>	32	164	X						
Shell Tellus S4 VX32 — Recommended	32	296	X						
Univis HVI 26 — <i>Optional</i>	26	376	X						
Shell Naturelle HF-E32 — Recommended	31	192		X			X	X	
Mobil EAL EnviroSyn H32 — <i>Optional</i>	34	146		X			X	X	

* cSt, Typical

** Readily biodegradable classification indicates one of the following:

CO2 Conversion > 60% per EPA 560/6-82-003

CO2 Conversion > 80% per CEC-L-33-A-93

† Virtually Non-toxic classification indicates a LC50 > 5000 ppm per OECD 203

‡ Fire Resistant classification indicates Factory Mutual Research Corp. (FMRC) Approval

Note: Shell Tellus S4 V32/Univis HVI 26 is available only to RT machines.

NOTICE

Machine operation using non-JLG approved hydraulic fluids or operation outside of the temperature boundaries outlined in the “Hydraulic Fluid Operation Chart” may result in premature wear or damage to components of the hydraulic system.

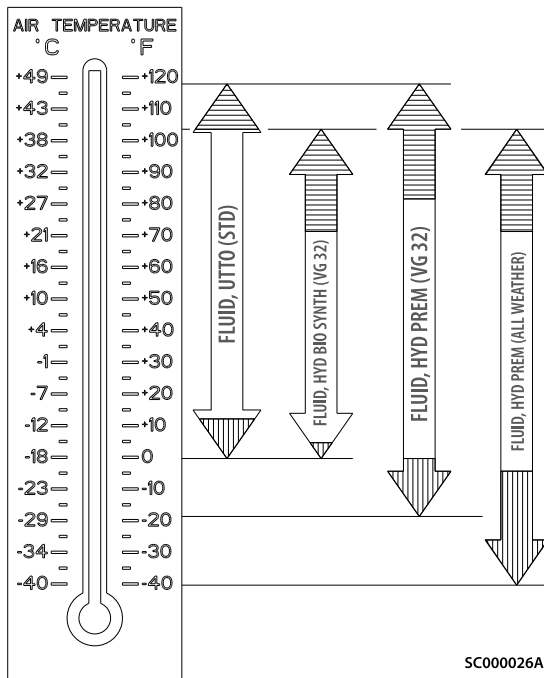

Figure 28. RT Machines — Hydraulic Oil

Higher Ambient Temperature Arrow

The addition of a hydraulic oil-cooler is highly recommended for prolonged operation in this temperature range (Consult JLG Service).



Lower Ambient Temperature Arrow

Operation in this temperature range should include the use of hydraulic system heating aids (Consult JLG Service).

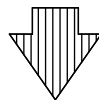

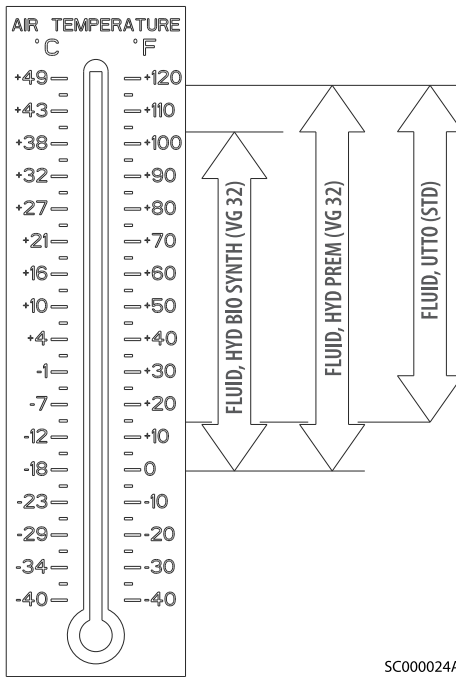

Figure 29. ERT Machines — Hydraulic Oil

Note: Some fluids may not be available from the factory.

6.7 SCISSOR ARM SAFETY PROP

! CAUTION

The safety prop must be used whenever maintenance performed on the machine requires the scissor arms to be raised.

The red safety prop is located at the rear of the machine in the armstack. To engage the safety prop:

1. Ensure there is no load in the platform. From the ground control station, raise the platform enough to allow the safety prop to be engaged.
2. Pull the ring to release the prop, then pull the prop down until it hangs vertically.
3. Lower the platform until the prop rests on the cross-shaft below.

4. To disengage, lift up the platform, pull the ring to release the prop, then lower the platform.

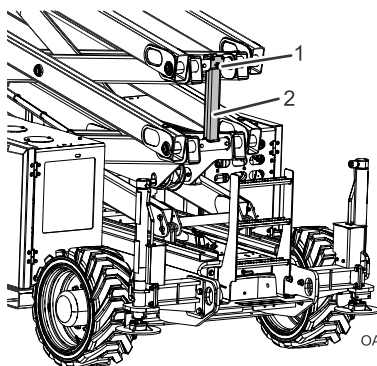
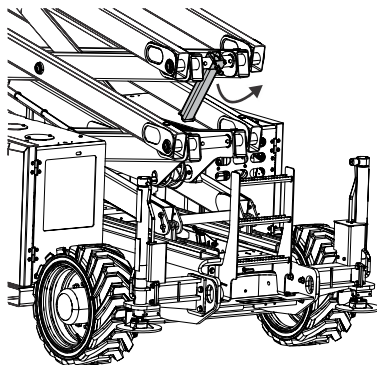

OAD02400

1. Release Ring

2. Scissor Arm Safety Prop

6.8 BATTERY MAINTENANCE AND CHARGING

⚠ WARNING

To avoid injury from an explosion, do not smoke or allow sparks or a flame near battery during servicing. Always wear eye and hand protection when servicing batteries.

6.8.1 Battery Charging (Daily)

WARNING

When battery charger is to be used, charging harness must be plugged into a grounded receptacle. If receptacle is not grounded and a malfunction should occur, the machine could cause serious electrical shock.

For increased battery life:

- Batteries should be kept at highest state of charge permitted by availability at job site and machine use. Charge batteries before they reach 20% state of charge. Avoid completely discharging the batteries.
- Fully charge the batteries each day the machine is used.
- Charge the batteries at available times between use. Flooded lead acid/AGM batteries do not develop a charging memory.
- If applicable, be sure the battery fluid covers the battery plates before charging. To avoid overflow, do not top off the fluid level until after charging.

CAUTION

When adding distilled water to the batteries, non-metallic containers and/or funnels must be used. Add water until electrolyte covers plates. Do not charge batteries unless electrolyte covers the plates.

Note: To avoid electrolyte overflow, add distilled water to batteries after charging. When adding water to the battery, fill only to level indicated or 3/8" above separators.

6.8.2 Battery Maintenance (Quarterly)

CAUTION

When adding distilled water to the batteries, non-metallic containers and/or funnels must be used. Add water until electrolyte covers plates. Do not charge batteries unless electrolyte covers the plates.

Note: To avoid electrolyte overflow, add distilled water to batteries after charging. When adding water to the battery, fill only to level indicated or 3/8" above separators.

1. Open battery compartment cover to allow access to battery terminals and vent caps.

2. Remove all vent caps and inspect electrolyte level of each cell. Electrolyte level should be to the ring approximately one inch from top of battery. Fill batteries with distilled water only. Replace and secure all vent caps.
3. Remove battery cables from each battery post one at a time, negative first. Clean cables with acid neutralizing solution (e.g., baking soda and water or ammonia) and wire brush. Replace cables and/or cable clamp bolts as required.
4. Clean battery post with wire brush then reconnect cable to post. Coat non-contact surfaces with mineral grease or petroleum jelly.
5. When all cables and terminal posts have been cleaned, ensure all cables are properly positioned and do not get pinched. Close battery compartment cover.
6. Power up machine and verify it functions properly.

6.9 BATTERY DISCONNECT (ERT MACHINES)

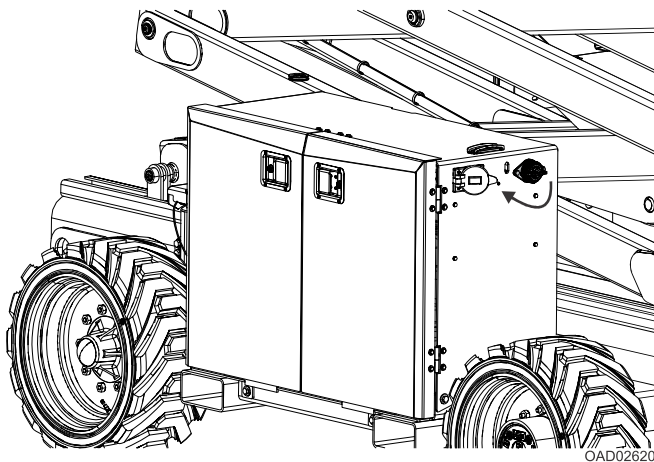

Electric machines have an accessible battery disconnect switch that allows all machine power to be easily disconnected at the batteries without removing battery cables from the battery posts. To disconnect batteries, locate the red switch on the right side of the battery compartment. Turn the switch clockwise to disconnect battery power from the machine. Turn the switch counterclockwise to return battery power to the machine.

6.10 OPERATOR MAINTENANCE

6.10.1 Fuel Tank

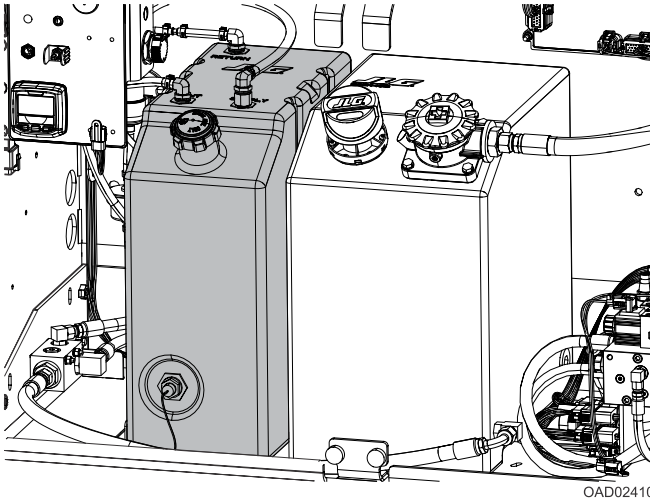

- Fuel — Diesel or gasoline (per engine type, refer to decal on the machine)
- Fill as required.

6.10.2 Hydraulic Oil Tank

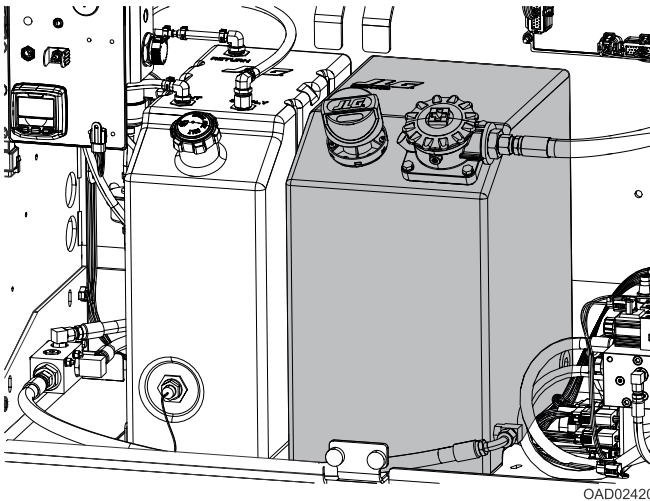

- Lube Point — Fill cap/fill level
- Lube — HO

- Interval — Check oil every 10 hours of operation; change oil every 2 years or 1200 hours of operation.

6.10.3 Drive Hub

- Lube Points — fill plugs (4)
- Lube — EPGL
- Interval — Every 2 years or 1200 hours

6.10.4 Scissor Arm Wear Pads

- Lube Points — 8 sliding wear pads
- Lube — MPG
- Interval — Every month or 50 hours.

6.10.5 Engine Coolant

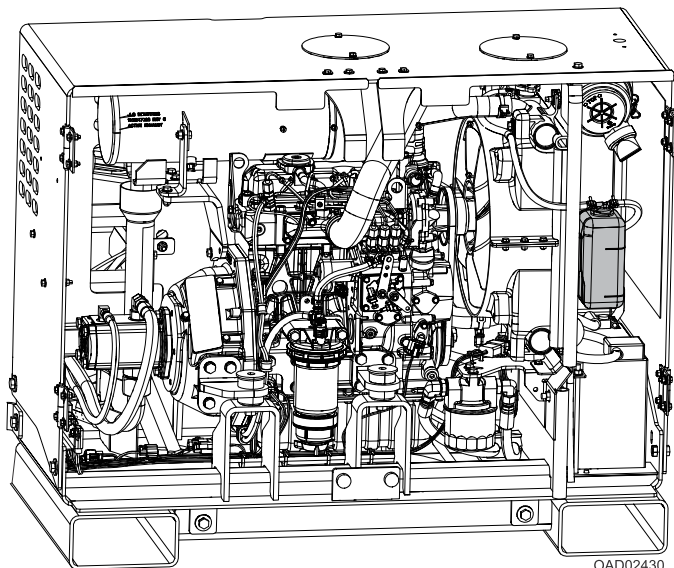

- Lube Point — Fill cap/fill level
- Interval — Check coolant level daily. Ensure it is between the full and low lines. If coolant level is low, allow fluid to cool, then add as required. Replace coolant annually in accordance with engine manual.

6.10.6 Air Filter

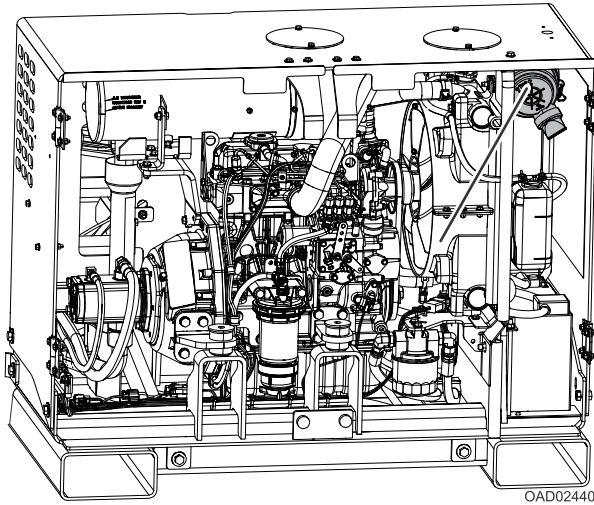

- Lube Points — Replaceable primary filter element (dry type)
- Interval — Every 6 months or 300 hours of operation. Under severe operating conditions (such as a very dusty work area), check condition of filter more often.
- Once a week squeeze the evacuator valve on bottom of air cleaner assembly to allow collected debris to fall out of the air cleaner.

6.10.7 Oil Change with Filter

Kubota Diesel (D1305-E4B)

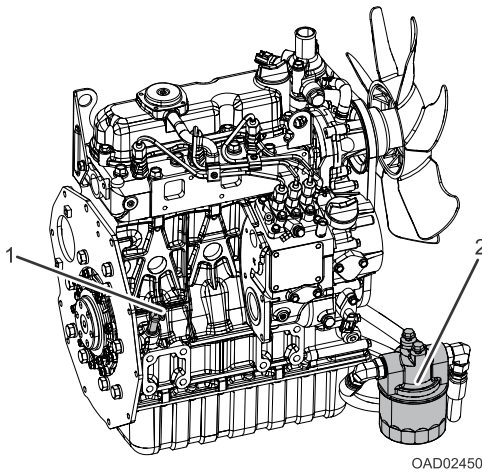

- Lube Point — Fill cap/spin-on element
- Lube — EO — Minimum API CF

- Interval — Initial oil and filter change at first 50 hours of operation, then every year or 200 hours of operation.

Kubota Dual Fuel (WG972–GL-E4)

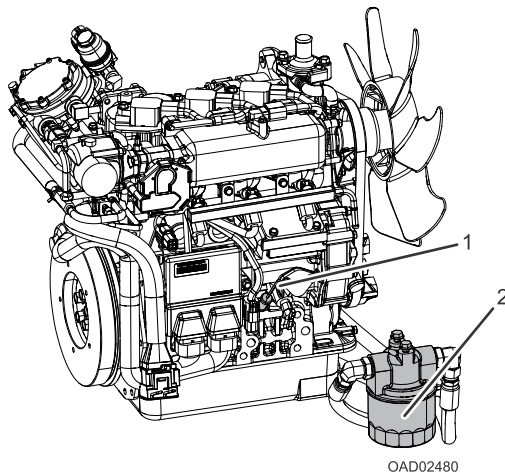

- Lube Point — Fill cap/spin on element
- Lube — EO — Minimum API SL
- Interval — Initial oil and filter change at first 50 hours of operation, then every year or 200 hours of operation.
- Check oil level daily **(1)** and maintain within marked level. Change oil and filter **(2)** in accordance with engine manual.

6.10.8 Fuel/Water Separator Filter (Diesel)

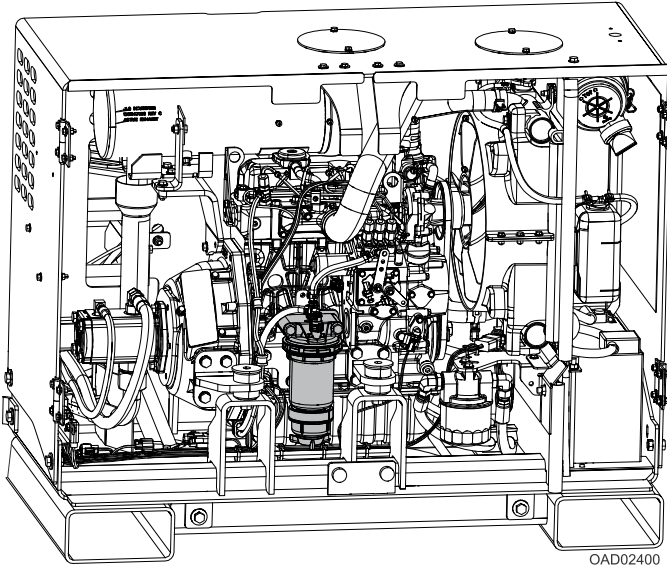

6.10.9 Fuel Strainer (Diesel)

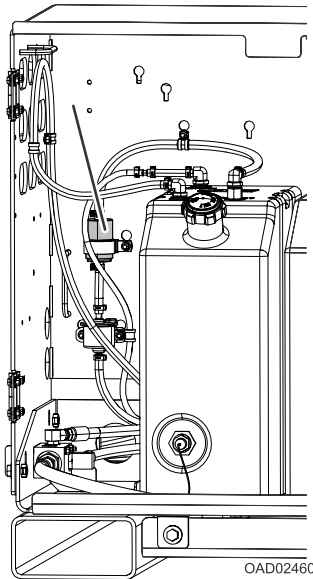

- Lube Point — Replaceable
- Interval — Every year or 750 hours of operation

6.10.10 Fuel Filter (Gas)

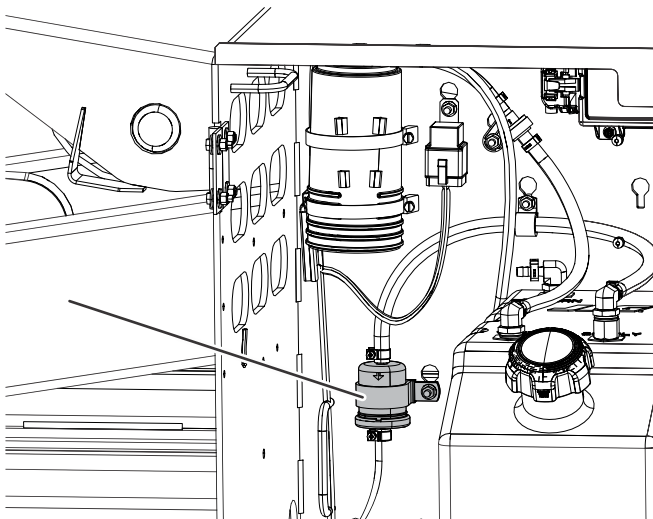

OAD02610

- Lube Point — Replaceable
- Interval — Check every 100 hours; change every year in accordance with engine manual.

6.11 ERT GENSET (IF EQUIPPED)

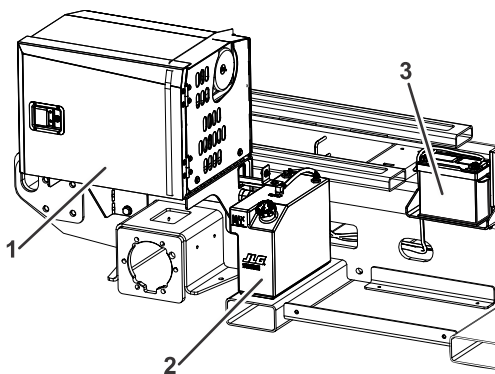

SC000026A

1. Genset System Compartment

2. Fuel Tank

3. Battery

6.11.1 Engine Specifications

Kubota Diesel (OC60-E4)	
Emissions	CARB, EPA Tier 4 Final, EU Stage V, China III
Fuel Type	Diesel: - Low Sulfur (<500 ppm) - Ultra Low Sulfur (15 ppm) (Required to meet EPA Tier 4 Final, EU Stage V) - Up to 5% biodiesel
Number of Cylinders	1
Engine RPM Control	Mechanical
Starter	12V, 0.7 kW
Starter Battery	12V, 20 hour rate @ 50 Ah
Fuel Consumption	0.41 gal/hr (1.6 L/hr)
Displacement	0.276 L (16.84 cu. in.)
Gross Power	6 Hp (4.5 kW) @ 3600 RPM
Gross Torque	9.7 ft. lb. (13.2 Nm) @ 2300 RPM

6.11.2 Fluid Capacities

Fuel Tank (Diesel)	4.5 gal (17 L)
Engine Oil	0.34 gal (1.3 L)

6.11.3 Operator Maintenance

Note: Some components removed in illustrations for clarity.

Fuel Filter

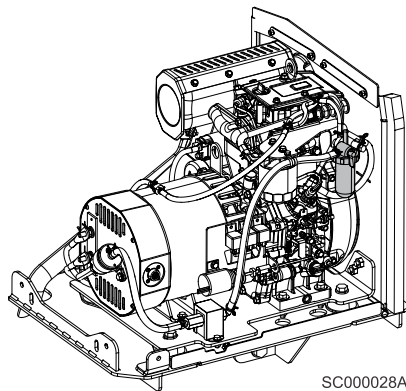

- Clean: 100 hours
- Replace: 500 hours

Fuel Tank

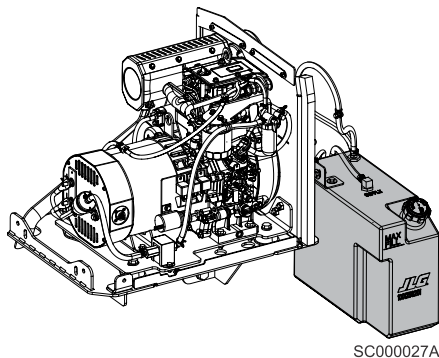

- Check: daily
- Replace: daily
- Clean: 300 hours

Oil Change with Filter/Cartridge

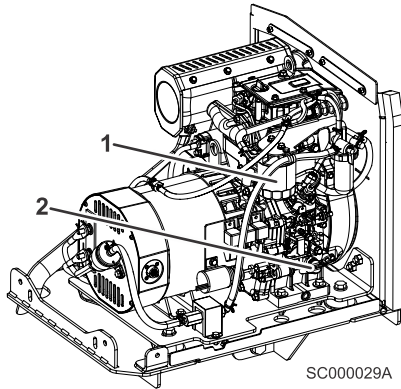

- Check (oil): Daily (1)
- Replenish (oil): Daily
- Replace (oil): 25 hours (after initial operation only)
- Replace (oil): 100 hours (normal operation)
- Replace (engine oil filter cartridge) (2): 25 hours (after initial operation only)
- Replace (engine oil filter cartridge) (2): 100 hours (normal operation)

Air Filter

- Check/Clean: 100 hours
- Replace: annually, or after every sixth cleaning

Note: If work site is especially dusty, check and clean the air filter every day.

Rubber Hoses and Clamp Bands

- Check: daily
- Replace: Every two years

Battery

- Check: 100 hours

Note: If battery is used for less than 100 hours in a year, check electrolyte level yearly.

6.12 PROPANE FUEL SYSTEM

6.12.1 Pressure Relief

CAUTION

The propane fuel system operates at pressures up to 312 psi (21.5 bar). To minimize the risk of fire and personal injury, relieve the propane fuel system pressure (where applicable) before servicing the propane fuel system components.

To relieve propane fuel system pressure:

1. Close the manual shut-off valve on the propane fuel tank.
2. Start and run the vehicle until the engine stalls.
3. Turn the ignition switch OFF.

CAUTION

Residual vapor pressure will be present in the fuel system. Ensure the work area is well ventilated before disconnecting any fuel line.

6.12.2 Leak Test

CAUTION

Never use an open flame of any type to check for propane fuel system leaks.

Always inspect the propane fuel system for leaks after performing service. Check for leaks at the fittings of the serviced or replaced component. Use a commercially available liquid leak detector or an electronic leak detector. When using both methods, use the electronic leak detector first to avoid contamination by the liquid leak detector.

6.13 TIRES AND WHEELS

6.13.1 Tire Damage

For polyurethane foam-filled tires, JLG Industries, Inc. recommends that when any of the following are discovered, measures must be taken to remove the JLG product from service immediately and arrangements must be made for replacement of the tire or tire assembly.

- a smooth, even cut through the cord plies which exceeds 3 in (7.5 cm) in total length

- any tears or rips (ragged edges) in the cord plies which exceed 1 in (2.5 cm) in any direction
- any punctures which exceed 1 in (2.5 cm) diameter
- any damage to the bead area cords of the tire

If a tire is damaged but is within the above noted criteria, the tire must be inspected on a daily basis to insure the damage has not propagated beyond the allowable criteria.

6.13.2 Tire Replacement

JLG recommends a replacement tire be the same size, ply and brand as originally installed on the machine. Please refer to the JLG Parts Manual for the part number of the approved tires for a particular machine model. If not using a JLG approved replacement tire, we recommend that replacement tires have the following characteristics:

- Equal or greater ply/load rating and size of original
- Tire tread contact width equal or greater than original
- Wheel diameter, width, and offset dimensions equal to the original
- Approved for the application by the tire manufacturer (including inflation pressure and maximum tire load)

Unless specifically approved by JLG Industries Inc. do not replace a foam filled or ballast filled tire assembly with a pneumatic tire. When selecting and installing a replacement tire, ensure that all tires are inflated to the pressure recommended by JLG. Due to size variations between tire brands, both tires on the same axle should be the same.

6.13.3 Wheel Replacement

The rims installed on each product model have been designed for stability requirements which consist of track width and load capacity. Size changes such as rim width, center piece location, larger or smaller diameter, etc., without written factory recommendations, may result in an unsafe condition regarding stability.

6.13.4 Wheel Installation

It is extremely important to apply and maintain proper wheel mounting torque.

WARNING

Wheel nuts must be installed and maintained at the proper torque to prevent loose wheels, broken studs, and possible dangerous separation of wheel from the axle. Be sure to use only the nuts matched to the cone angle of the wheel.

Tighten the lug nuts to the proper torque to prevent wheels from coming loose. Use a torque wrench to tighten the fasteners. If you do not have a torque wrench, tighten the fasteners with a lug wrench, then immediately have a service garage or dealer tighten the lug nuts to the proper torque. Over-tightening will result in breaking the studs or permanently deforming the mounting stud holes in the wheels. The proper procedure for attaching wheels is as follows:

1. Start all nuts by hand to prevent cross threading. DO NOT use a lubricant on threads or nuts.
2. Tighten nuts in the following sequence:

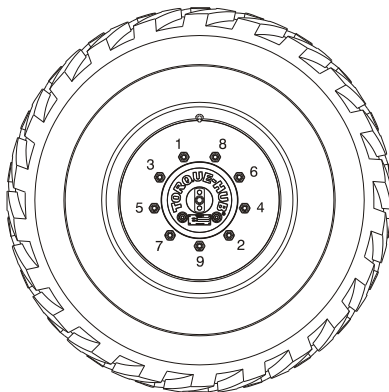

3. The tightening of the nuts should be done in stages. Following the recommended sequence, tighten nuts per wheel torque chart.
4. Wheel nuts should be torqued after first 50 hours of operation and after each wheel removal. Check torque every 3 months or 150 hours of operation.

Table 11. Wheel Torque Chart

TORQUE SEQUENCE		
1st Stage	2nd Stage	3rd Stage
85 ft. lb. (115 Nm)	110 ft. lb. (149 Nm)	170 ft. lb. (230 Nm)

6.14 SUPPLEMENTAL INFORMATION ONLY APPLICABLE TO CE/UKCA MACHINES

The following information is provided in accordance with the requirements of the European Machinery Directive 2006/42/EC or Supply of Machinery (Safety) Regulations 2008 No. 1597.

The A-Weighted emission sound pressure level at the work platform is less than 70 dB (A).

The guaranteed Sound Power Level (LWA) per European Directive 2000/14/EC (Noise Emission in the Environment by Equipment for Use Outdoors) or Noise Emission in the Environment by Equipment for use Outdoors Regulations 2001 No. 1701 based on test methods in accordance with Annex III, Part B, Method 1 and 0 of the directive, is 99 dB (A).

The vibration total value to which the hand-arm system is subjected does not exceed 2,5 m/s². The highest root mean square value of weighted acceleration to which the whole body is subjected does not exceed 0,5 m/s².

6.15 EC DECLARATION OF CONFORMITY

Manufacturer

JLG Industries, Inc.

Address

1 JLG Drive
McConnellsburg, PA 17233 USA

Technical File

JLG EMEA B.V.
Polaris avenue 63,
2132 JH Hoofddorp
The Netherlands

Contact/Position

Senior Manager — Product Safety & Reliability

Date/Place

Hoofddorp, Netherlands

Machine Type

Mobile Elevating Work Platform

Model Type

RT2669, ERT2669, RT3369, ERT3369
RT4069, ERT4069, RT4769, ERT4769

EC-Number

NB 0123

Certificate Number

M6A 021821 0008

Notified Body

TÜV SÜD Product Service GmbH

Address

Ridlerstrasse 65, 80339 Munich, Germany

Reference Standards

- EN 55011:2009/A1:2010
- EN 61000-6-2:2005
- EN 60204-1:2018
- EN 280:2013+ A1:2015
- EN ISO 12100:2010

JLG Industries, Inc. hereby declares that the above mentioned machine conforms with the requirements of:

- 2006/42/EC — Machinery Directive
- 2014/30/EU — EMC Directive
- 2014/53/EU — RED Directive (If fitted with optional equipment)
- 2000/14/EC — Outdoor Noise Directive

Note: This declaration conforms with the requirements of annex II-A of the council directive 2006/42/EC. Any modification of the above described machine violates the validity of this declaration.

6.16 UKCA DECLARATION OF CONFORMITY

Manufacturer

JLG Industries, Inc.

Address

1 JLG Drive
McConnellsburg, PA 17233 USA

Technical File

JLG Industries UK Ltd
Braunstone Frith Industrial Estate
Unit 3 Sunningdale Road
Leicester, LE3 1UX
United Kingdom

Contact/Position

Director of Engineering — Europe

Date/Place

Leicester, United Kingdom

Machine Type

Mobile Elevating Work Platform

Model Type

RT2669, ERT2669, RT3369, ERT3369
RT4069, ERT4069, RT4769, ERT4769

AB-Number

0172

Certificate Number

UK-MAC000062

Approved Body

TUV SUD BABT Unlimited

Address

Octagon House, Concorde Way, Segensworth North,
Fareham, Hampshire PO 15 5RL

Reference Standards

- EN 55011:2009/A1:2010
- EN 61000-6-2:2005
- EN 60204-1:2018
- EN 280:2013+ A1:2015
- EN ISO 12100:2010

JLG Industries, Inc. hereby declares that the above mentioned machine conforms with the requirements of:

- 2008 No. 1597 - Supply of Machinery (Safety) Regulations 2008
- 2016 No. 1091 - Electromagnetic Compatibility Regulations 20165
- 2017 No. 1206 - Radio Equipment Regulations 2017 (if fitted with optional equipment)
- 2001 No. 1701 - Noise Emission in the Environment by Equipment for use Outdoors Regulations 2001

Note: This declaration conforms with the requirements of annex II-A of the Regulations 2008 No. 1597. Any modification of the above described machine violates the validity of this declaration.

This Page is intentionally left blank



Corporate Office
JLG Industries, Inc.
1 JLG Drive
McConnellsburg, PA 17233-9533 USA
☎ (717) 485-5161 (Corporate)
☎ (877) 554-5438 (Customer Support)
☎ (717) 485-6417

Visit our website for JLG Worldwide Locations.
www.jlg.com



OSHKOSH™