



LEADERS IN COMPACTION.

ARTICULATED TANDEM ROLLERS, UP TO 5 T.



MILLIONS OF KILOMETRES BEAR OUR SIGNATURE.

You build the finest roads so we can all make the quickest progress. And to ensure your rapid progress, we build the best machines. As a member of the leading international FAYAT group, we supply machines for all areas of road construction: from soil compactors to cold planers and recyclers, and asphalt rollers to pavers. For over 60 years, the history of our company has been synonymous with the history of road construction.

With our accumulated know-how, we are an innovation driver that sets the pace for an entire industry. BOMAG has developed a wide range of technologies, from systems for measuring and controlling compaction (such as the ECONOMIZER and ASPHALT MANAGER) to technologies for reducing operating costs (such as ECOMODE,) and the most effective screed heating on the market: MAGMALIFE. We offer solutions for a wide variety of applications.

Our global network of experts and trade partners in over 120 countries supports you with everything from the configuration of the machines to providing solutions for the most challenging of tasks.

We owe our innovative strength to our more than 2,300 employees worldwide, their commitment, and their unique wealth of experience. A source of expertise that has made us the global market leader in this sector. The reason for this is our unconditional commitment to quality: in product development and production, the qualification of our employees, and a service that guarantees optimal on-site support.







BW 80 AD-5

BW 90 AD-5

BW 100 ADM-5

FULL RANGE FOR EVERY APPLICATION.

ASPHALT COMPACTION IS A JOB FOR BOMAG SPECIALISTS.

Just because you're using a compact machine doesn't mean you should miss out on productivity, operator comfort, performance and innovation. This is why our engineers do all they can to make each new generation even better, more economical and more productive.

Always with one aim: every BOMAG machine must enable our customers to work more efficiently, safely and professionally. Staying in close contact with our customers allows us to find solutions that lead to real productivity gains and enable them to perform their many tasks perfectly.



BW 100 AD-5

BW 120 AD-5

BW 135 AD-5

BW 138 AD-5

LIGHT TANDEM ROLLERS FOR SOIL COMPACTION AND ASPHALT CONSTRUCTION.

Ideal for paving and repairs as well as finishing work in road construction. Compact BOMAG tandem rollers have also earned an excellent reputation in landscaping.

We are also setting new standards in compact tandem rollers with up to 5 t operating weight. In doing so, BOMAG focuses on closely matching your requirements. So trust our engineers' expertise and the service philosophy of our

distribution network. Trust in the legendary BOMAG quality. Because at BOMAG, we have just one goal: to make your work more productive.



THE ALL-ROUNDER FOR YOUR CONSTRUCTION SITES.

QUICKLY SERVICED.

BOMAG machines have no lubrication nipple. The articulated joint is maintenance-free. Engine, central electrics and water pump are easy to access. That saves time and effort in daily maintenance.

ROBUST WORKMANSHIP.

The maintenance-free articulated joint is firmly bolted to the front and rear wheels and easily accessible for servicing.

TRANSPARENT WORK.

Supporting systems and technologies such as ECONOMIZER, JOBLINK and BOMAP help to avoid unnecessary passes and improve the quality of work results, thus effectively lowering costs.





CONVENIENT OPERATION.

The spacious driver's platform with a compact steering wheel has a robust dashboard with large switches. Intuitive operation via a soft response travel lever and an excellent overview of the drum edges ensure relaxed and safe working.



CLEANLY SEPARATED.

Wind-protected spray nozzles ensure even wetting of the drums in all conditions.



COMFORTABLE WORKING GUARANTEED.

Ample space and legroom on the operator platform ensure a comfortable workday. The compact steering wheel and large access steps allow the operator to climb up and down safely and comfortably.

EVERY OPERATOR IS HAPPY TO WORK HERE.

Light tandem rollers are frequently used by many different operators on a wide variety of construction sites. Every operator must therefore find their way around immediately and feel at ease with the controls. With the development of many user-oriented functions and great attention to detail, our engineers have ensured that your operators enjoy working with a BOMAG. Because a contented operator is a productive operator.

USER-FRIENDLY AS STANDARD.

All functions are self-explanatory and can be operated intuitively in next to no time. As with every BOMAG tandem roller, the main functions can be operated safely and unmistakably using the ergonomic travel lever.



Large switches, a compact steering wheel and clearly arranged control elements make it easy for any operator to work with a light BOMAG tandem roller.

COMFORTABLE COMPACTION WORK.

The travel lever's response is very pleasant, and reversing very precise. Drum vibration can be activated selectively for the front or rear only or for both drums. In combination with the IVC system (Intelligent Vibration Control), the exciter system ensures consistent compaction and reliable operation at all times.



Ample legroom for the operator ensures a pleasant working environment.

POWERFUL, ECONOMIC AND EASY TO MAINTAIN.

A high level of in-house production, strict quality controls and the enormous demands we place on the durability of our machines make BOMAG light tandem rollers uncomplicated long-distance runners on your construction site.



HIGHEST QUALITY FOR TOUGH EVERYDAY ON-SITE OPERATION.

- BOMAG vibration system with legendary operating reliability
- Engine hood made of special impact-resistant plastic
- Reliable and economical engines
- Braided cables ensure trouble-free electrics

SIMPLE DAILY MAINTENANCE.

- No lubrication points on the entire machine
- Easy access to engine compartment, central electrics and water pump
- Central water and emulsion drain with filling valve



Braided cables and excellent accessibility ensure high operational safety.

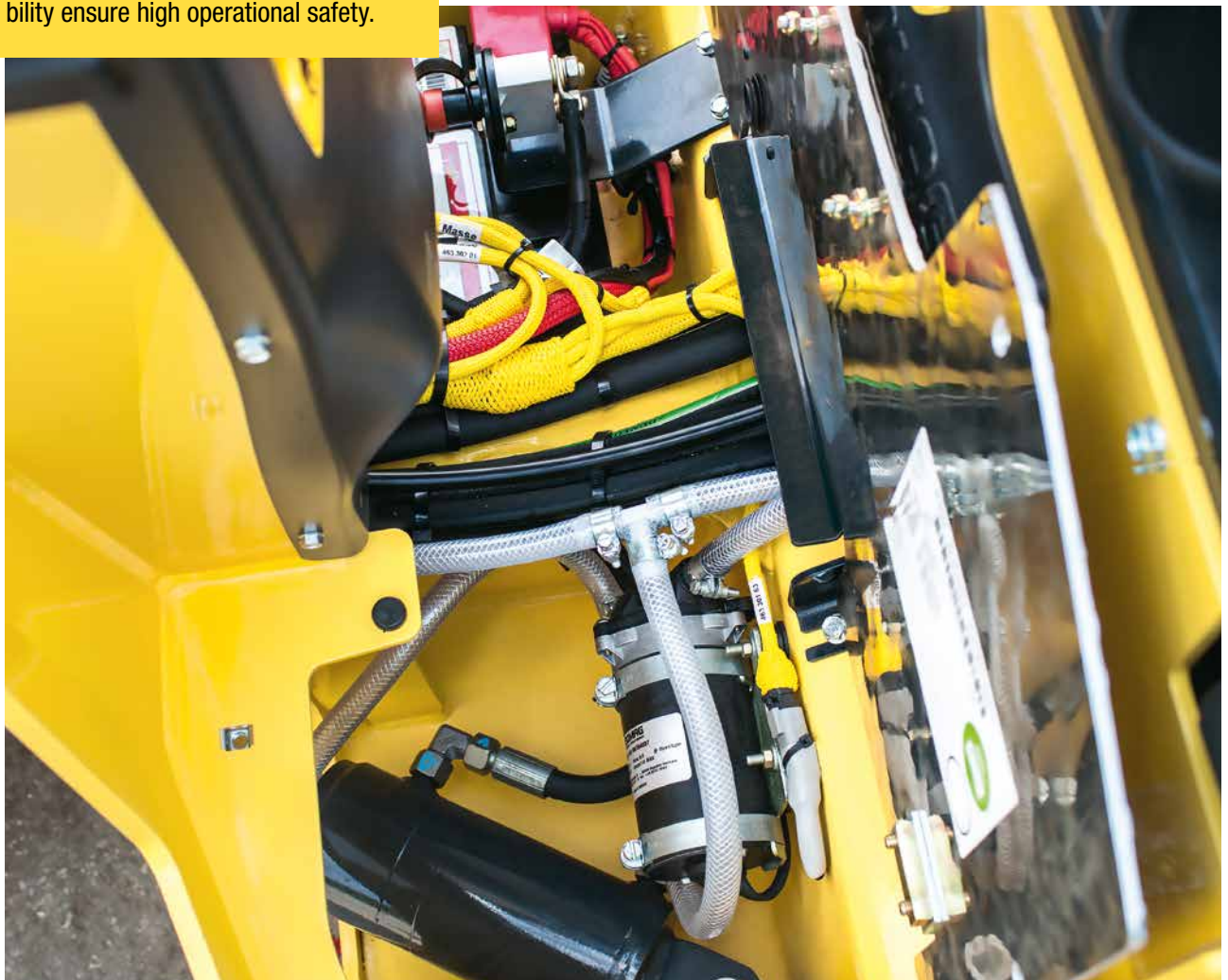

DETAILS MAKE ALL THE DIFFERENCE.

There's no such thing as can't do. BOMAG developed their lightweight tandem rollers hand in hand with experienced construction site operatives. Every detail of the machines has been meticulously thought through and tailored to the harsh conditions of the world's construction sites. And every single one makes work easier for you and your operators.



FAIL-SAFE.

- Pressurized spraying system with high-quality pump and 5-stage interval system and large water tank
- Up to five wind-protected spray nozzles per drum are easy to access and replace
- 2-filter system to prevent clogged nozzles

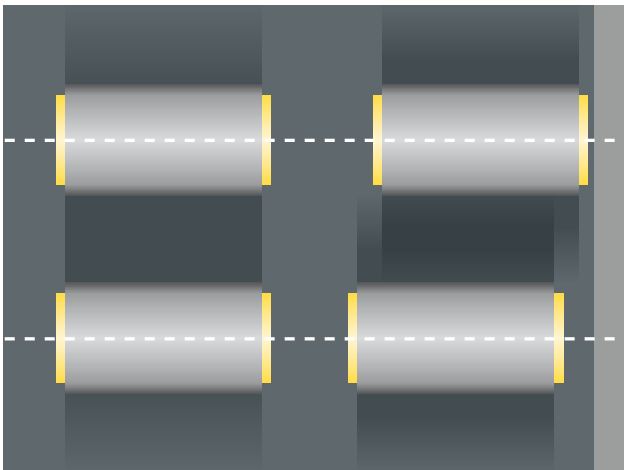

INEXPENSIVE AND FLEXIBLE.

- Cost-savings due to maintenance-free articulated joint without lubrication nipple
- Articulated joint securely bolted to the frame – easily accessible for servicing
- Crabwalk as standard (also hydraulic option) with an infinitely variable offset of up to 5 cm to the right for simpler work on edge areas and borders



Every machine comes with a sufficient number of sturdy and practical lashing eyes to secure the machines for transport.



The single lifting point on each roller is always at the machine's centre of gravity, making it easier to load and unload.

EDGE PRESSING AND CUTTING TOOL.

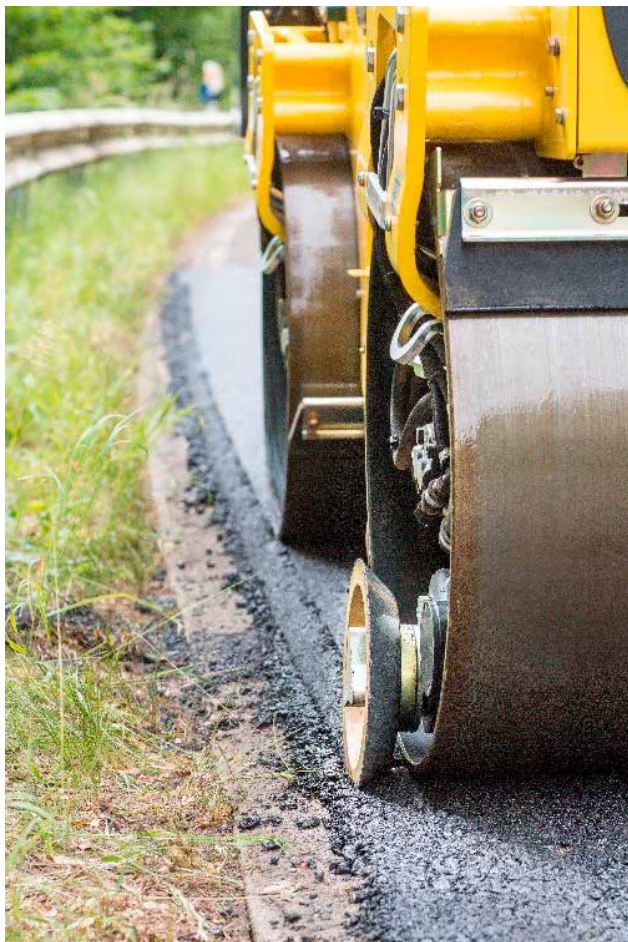





CLEAN EDGES.

The edge cutter can be equipped with various tools for cutting and pressing and operated comfortably with the travel lever. Thanks to the quick-release couplings, no special tools are required to mount or remove the edge cutter.

- The drum edge lighting always guarantees the best view of the drum edge, even in the dark
- An optional orientation rod helps the driver stay on track better and further improve quality

Attachment position	BW 80 – 100 ADM	BW 100 – 120	BW 135 – 138
Front right	X	X	X
Front left	X (SC & SCC)		
Front right and left		X	X
Water spraying	X	X	X

Pressure rollers and cutting wheel

Pressure roller 45°		Pressure roller 2°	
Pressure roller 60°		Cutting disc	

CHIP SPREADER.

SPREAD EVENLY.

The agitator roller ensures an even supply of the material being spread. The metering slider allows individual adjustment of the spread rate. The spreader itself is additionally equipped with a tarpaulin and separate lighting.

- Spread rate via metering slider
- Uniform supply of material being spread by the agitator roller
- Tarpaulin + spreader lighting

Type	Availability	Spreading width (m)	BW 135 Capacity (l)
BS 100	BW 100 – BW 120	1.0	200
BS 120	BW 135 – BW 138	1.2	240



HYDRAULIC CRABWALK AND SECOND AMPLITUDE.



HYDRAULIC ADJUSTMENT OF CRABWALK.

The front drum shifts to the right by up to 50 mm. This simplifies work on edge areas and borders. The hydraulic crabwalk is activated via the green buttons on the left travel lever.

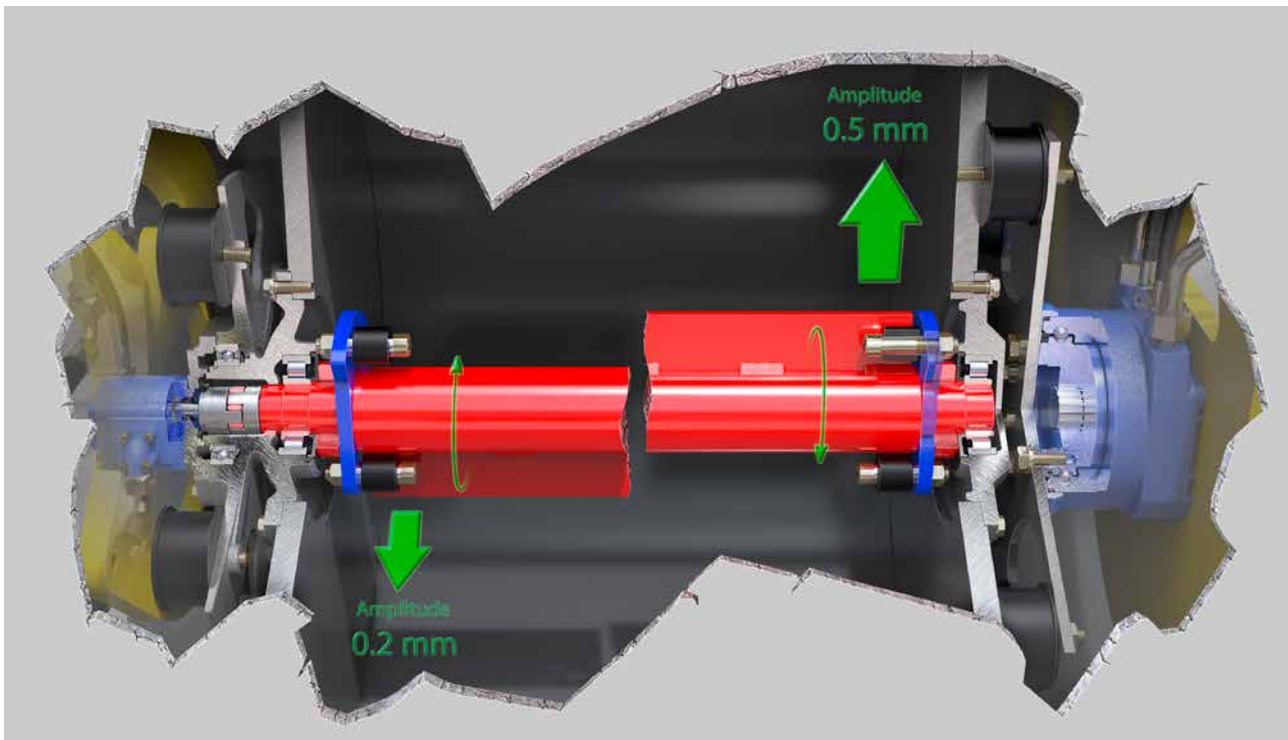

SECOND AMPLITUDE.

The machine is equipped with a small amplitude of 0.2 mm in addition to the normal amplitude of 0.5 mm. The small amplitude is particularly suitable for compacting thin layers and work on bridges and in inner-city areas because it

ensures gentle compaction and reduces the risk of crushing aggregates. It is operated by a rotary switch on the operating console.

SUNROOF, WEATHER PROTECTION CAB, DOUBLE TRAVEL LEVER.



WELL SHADED.

The optional sunroof can be folded and provides protection from the sun and additional safety with the ROPS fitted as standard. The roof can be folded and unfolded without the need for tools. Additional protection from wind and rain is provided by the weather protection foils.



IN ANY WEATHER.

The weather protection cab is glazed at the front and rear, and the sides can be opened and closed with a flexible foil. This makes working on the construction site even more comfortable. The roller driver sits in the dry even in bad weather and can perform work comfortably and safely. The front and rear view through the cabin is not impaired.



EVERYTHING UNDER CONTROL.

Optional double travel levers ensure enhanced travel and operating comfort. In combination with the seat with durable sliding function, they make it easier for the operator to work and manoeuvre. Both travel levers are equipped with control switches for the horn, vibration and, if required, edge cutter.

THE DIGITAL CONSTRUCTION SITE.

KNOWLEDGE IS PLANNING POWER!

BOMAG's compact tandem rollers are also ready for the future. A future in which all machines on the site are connected, process data is transmitted in real time, and you, as a contractor, can achieve a new level of planning reliability thanks to 100% transparency.

To achieve this comprehensive transparency, BOMAG has combined a whole range of modules into TELEMATIC to provide one integrated solution. It forms the backbone and prerequisite for construction site digitisation.

With JOBLINK, the unbeatable potential of BOMAP comes into play. BOMAG machines are equipped with intelligent measuring technology and process sensors. The BOMAG JOBLINK interface collects all process-relevant parameters from measuring systems and the machine and makes them available for further processing, e.g. in BOMAP: E_{VIB} , frequency, amplitude (for heavy tandem rollers), temperature (for pavers), screed width (on pavers), as well as travel speed are just some of the numerous parameters JOBLINK provides to its users. Machines with ECONOMIZER can also provide their compaction information and the asphalt temperature.

A connection to BOMAP is automatically initiated when the machine is started. As soon as the wireless connection via the JOBLINK plug-and-play Bluetooth adapter is established, BOMAP independently takes over the machine configuration. All the measuring data appears in the app automatically – without the need for additional equipment. An additional JOBLINK dashboard serves as a visual aid. As a consequence, the relevant measured values can be displayed in the driver's field of vision at any time without losing sight of the lane. The final documentation contains all the measuring data sent to BOMAP via JOBLINK. Regardless of whether it concerns soil compaction or asphalt paving, you can now meet any future tender requirements, such as Surface Covering Dynamic Compaction Control (SCDCC).

BOMAP Connect links the machines together, for example, to create a complete compaction map of the construction site – across all machines, even from different manufacturers. The result is a transparent construction site. Thanks to this unique link, BOMAG is the only company that can map and document everything from planning to the finished compacted asphalt in real time. For your company, this means: better offers, better work processes, and maximum planning capability. Effort and return are optimally balanced.

LEADING THE WAY IN DIGITAL SOLUTIONS.

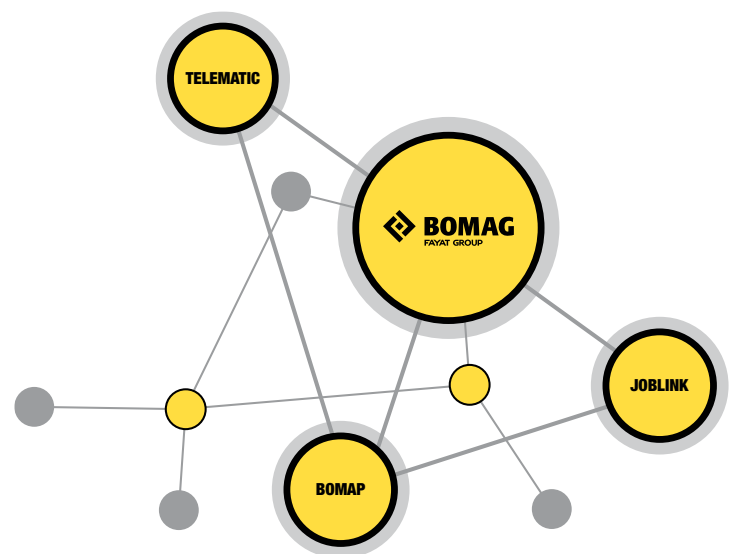



BOMAG MACHINES.
YOUR GUARANTEE FOR
SUCCESS.



JOBLINK.
THE OPEN
INTERFACE.

360° DIGITAL



TELEMATIC.
THE EFFICIENT
FLEET MANAGER.



BOMAP.
YOUR SMART HELPER ON
THE CONSTRUCTION SITE.

EFFORTLESS COMPETENCE EVERY TIME.

Whether for asphalt or earthworks – compaction is a breeze with BOMAG tandem rollers. The self-explanatory operation of all the functions and optimal performance of the machines are decisive in ensuring the highest quality at every construction site.





SIMPLE AND CLEAN COMPACTION.

To increase flexibility in confined spaces, BOMAG offers rollers with open-sided drums. The drums are suspended on one side only and off-centre. As a result, they can compact cleanly right up to high walls of e.g. buildings and other boundaries.

SURFACES OF THE HIGHEST QUALITY.

Using BOMAG light combination rollers on the construction site can considerably improve the quality of the asphalt surface. The rolling and kneading effect of the rubber wheels draws bitumen to the surface and achieves maximum sealing of the asphalt layer. The tyres' adaptability also enables clean compaction on transitions and edges.



ALWAYS THE RIGHT CHOICE: BOMAG ORIGINAL PARTS AND SERVICE.

You deliberately opted for a BOMAG when deciding on your machine. To ensure the long-term performance of your equipment, you can also rely on the tried and trusted quality of BOMAG's services and genuine parts.

PROVEN BOMAG RELIABILITY.

When you buy a BOMAG machine, you also receive expert service and flexible access to Genuine Parts. We are your reliable global partner, with 12 subsidiaries abroad and

over 500 dealers in more than 120 countries. No matter where your machine is in use, we won't let you down!

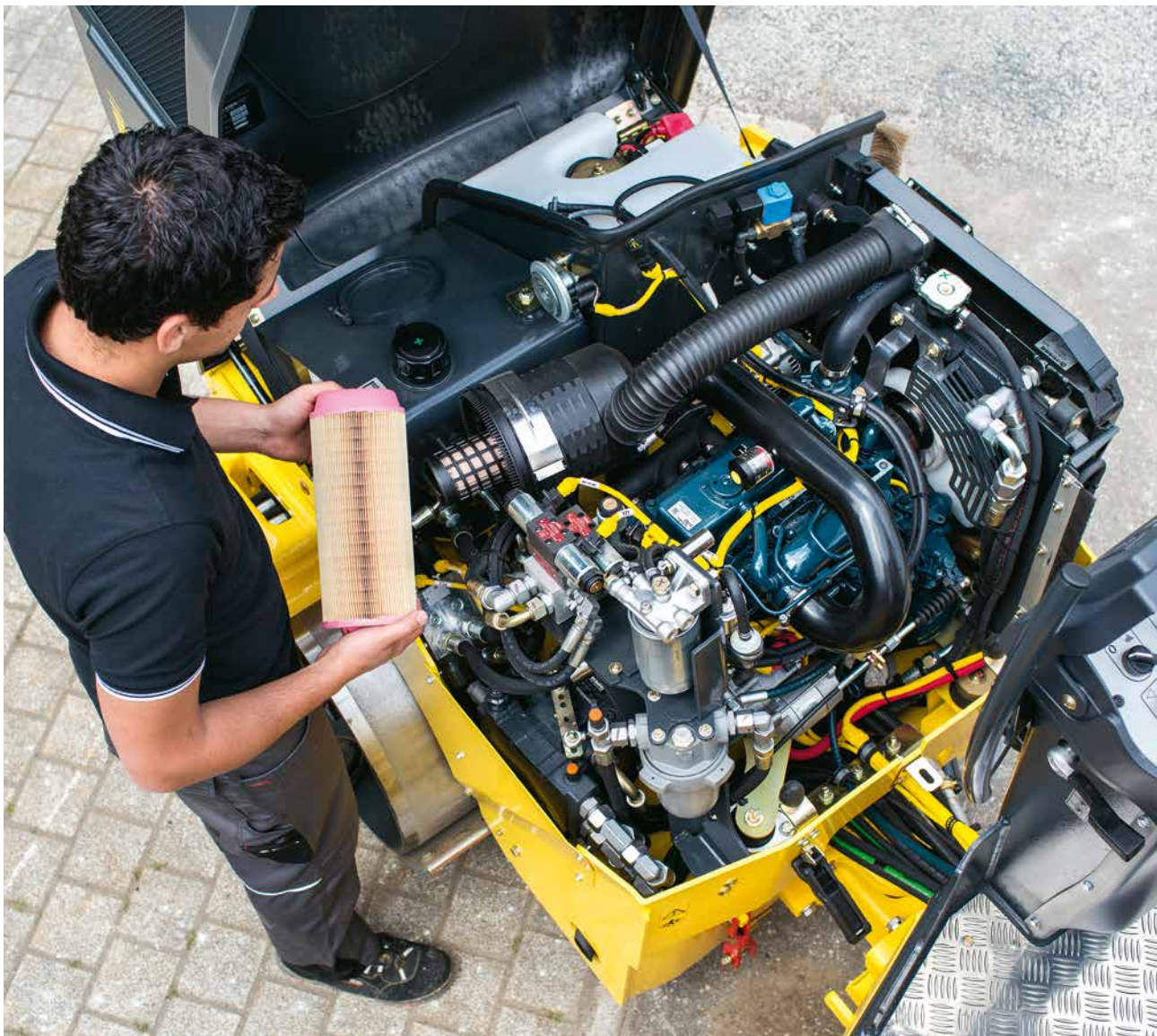

Optimum accessibility to all machine components simplifies the operator's daily maintenance. And maintenance that is simple and convenient also gets done.



INIMITABLY BOMAG.

BOMAG genuine parts are tailored precisely to your machine and characterised by their outstanding reliability and proven quality. Unlike replicas, they fulfil the highest quality standards in terms of functionality and durability, so your BOMAG stays a BOMAG.



WHAT ARE YOU WAITING FOR?

BOMAG service kits are individually configured by our service experts for your BOMAG machine and contain all the components required for maintenance in one convenient package. This saves you both time and money – up to 15% compared to single part orders.



ALWAYS AT THE READY.

BOMAG water spray kits are specially designed for BOMAG tandem rollers to enable the replacement of sprinkler parts quickly and efficiently on site. In their practical carrying case, they can be taken anywhere and the components can be replaced immediately if necessary, so the machine is quickly up and running again.



YOUR PLUS IN RELIABILITY

BOMAG PartnerPlus offers peace of mind at a calculable price. You decide yourself on the scope of services and select from a comprehensive range of maintenance, repair and optional additional packages. BOMAG's PartnerPlus programme keeps you flexible and increases the operational reliability of your equipment.

MODEL OVERVIEW.

BOMAG offers the right machine for every application. Select the roller and equipment that perfectly matches your needs and your company from 14 different models.



The light tandem roller product range from 1.55 to 4.5 t



BW 80/90/100: the lightweights up to 1.8 t.



BW 135/138: the heavyweights from 4.0 to 4.5 t.

Model types	Operating weight approx. [t]*	Working width [mm]	Power [kW]
BW 80 AD-5	1,550	800	15.1
BW 90 AD-5	1,600	900	15.1
BW 90 SC-5 (side clearance)	1,650	960	15.1
BW 900-50	1,200	900	14.9
BW 90 SL-5	1,350	900	15.1
BW 90 AC-5 (combination roller)	1,600	900	15.1
BW 90 SCC-5 (combination roller, side clearance)	1,600	900	15.1
BW 100 ADM-5	1,700	1,000	15.1
BW 100 SC-5 (side clearance)	1,700	1,060	15.1
BW 100 ACM-5 (combination roller)	1,700	1,000	15.1
BW 100 SCC-5 (combination roller, side clearance)	1,700	1,000	15.1
BW 100 AD-5	2,500/2,550	1,000	18.5/24.3/24.6
BW 100 SL-5	2,350	1,000	18.5
BW 100 AC-5 (combination roller)	2,350/2,400	1,000	18.5/24.3/24.6
BW 120 AD-5	2,700/2,750	1,200	18.5/24.3/24.6
BW 120 SL-5	2,500	1,200	18.5
BW 120 AC-5 (combination roller)	2,450/2,500	1,200	18.5/24.3/24.6
BW 120 SLC-5 (combination roller)	2,250	1,200	18.5
BW 135 AD-5	4,000/4,050	1,300	33.3/34.1
BW 138 AD-5	4,450/4,500	1,380	33.3/34.1
BW 138 AC-5 (combination roller)	4,150/4,200	1,380	33.3/34.1

* Approximate operating weights with basic equipment. Actual weights depend on equipment and accessories. Technical modifications reserved. Machines may be shown with optional accessories.

PERFECTION DOESN'T HAPPEN BY CHANCE!

Our entire expertise is also embodied in every light BOMAG tandem roller – down to the smallest detail. So you can put all your experience into your work. The result: visible success. On every single job.





BOMAG
FAYAT GROUP

Head Office:

BOMAG
Hellerwald
56154 Boppard
GERMANY
Tel. +49 6742 100-0
info@bomag.com

**BOMAG Maschinen-
handels-gesellschaft m.b.H.**

Klausenweg 654
2534 Alland
AUSTRIA
Tel. +43 2258 20202
austria@bomag.com

BOMAG MARINI EQUIPAMENTOS LTDA.

Avenida Clemente Cifali, 530
Distrito Industrial Ritter
Cachoeirinha – RS
BRAZIL
ZIP code 94935-225
Tel. +55 51 2125-6642
brasil@bomag.com

BOMAG (CANADA), INC.

2233 Argentia Road, East Tower
Suites 302
L5N 2X7 Mississauga, ON
CANADA
Tel. +1 800 782 6624
canada@bomag.com

BOMAG (CHANGZHOU)

Construction Machinery Co., Ltd.
No. 66 Bopa Road
Xuejia Town
Xinbei District
Changzhou 213125
CHINA
Tel: +86 519 88585566
china@bomag.com

BOMAG India Pvt Ltd

Unit No. 614, B Wing, 6th Floor
Kanakia Wall Street
Chakala Andheri Kurla Road Andheri East
Mumbai 400 093 Maharashtra
INDIA
Tel.: +91 8657492418
india@bomag.com

BOMAG France S.A.S.

2, Avenue du Général de Gaulle
91170 Viry-Châtillon
FRANCE
Tel. +33 1 69578600
france@bomag.com

BOMAG (GREAT BRITAIN), LTD.

Sheldon Way
Larkfield, Aylesford
Kent ME20 6SE
GREAT BRITAIN
Tel. +44 1622 716611
gb@bomag.com

BOMAG Italia

Via Roma 50
48011 Alfonsine
ITALY
Tel. +39 0544 864235
italy@bomag.com

FAYAT BOMAG Polska Sp. z o.o.

Ul. Szyszkowa 52
02-285 Warszawa
POLAND
Tel. +48 22 482 04 00
poland@bomag.com

FAYAT BOMAG RUS OOO

141400, RF, Moscow region
Khimki, Klayazma block, h. 1-g
RUSSIA
Tel. +7 (495) 287 92 90
russia@bomag.com

BOMAG GmbH

300 Beach Road
The Concourse, #18-06
Singapore 199555
SINGAPORE
Tel. +65 6 294 1277
singapore@bomag.com

BOMAG Americas, Inc.

125 Blue Granite Parkway
Ridgeway SC 29130
U.S.A.
Tel. +1 803 3370700
usa@bomag.com