

Engine output : 15.7 PS  
Machine weight : 960 kg

For Earth, For Life  
**Kubota**

# *KC110 HR-4*

**KUBOTA TRACKED DUMPER**



# COMPACT, POWERFUL AND DESIGNED FOR OPTIMUM COMFORT, THE NEW KUBOTA KC110HR-4 SAVES YOU TIME AND TROUBLE.



## Unloading operation

Unloading operation is fast and easy. The profile of the skip has been designed to ensure a quick discharge of the material. With a dumping angle of 90°, all materials exit easily from the skip. In addition, the rotary function allows you to tip side ways (180°) when filling a trench for example.



## Clean environmentally friendly engine

Tough and reliable, the water cooled KUBOTA diesel engine delivers high torque, enhanced power (15.7 PS at 2550 rpm) and optimum fuel efficiency to minimise operating costs. It also features cleaner emissions and quieter operation and quieter operation which means it has lower impact on the environment.



## Loading capacity

With a maximum loading capacity of 1000 kg and an heaped volume of 0,52 m<sup>3</sup>, the KC110HR-4 is a truly productive machine on any work site.



## Comfortable and easy operation

All levers and controls are easy to reach and operate. A grab handle bar secures the operator during operation.



# KUBOTA TRACKED DUMPER

## KC110HR-4



### Compact design

With an overall width of only 990 mm, the KC110HR-4 efficiently transports material through gates and doorways, between houses, buildings and many other narrow spaces.



### Foldable foot plate

The KC110HR-4 features a foldable foot plate. When the plate is down, the operator can safely stand on it to operate the machine. When the plate is folded up, the overall length is reduced by 250 mm in order to gain space for transport or storage. The standing operation position makes it easier when getting on and off the machine.



### Skip rotation

The skip rotation is powered by a hydraulic swivel motor mounted on a slew ring which insures smooth, precise and fast rotation of the skip through 180°.



### Automatic speed shift

The KC110HR-4 features a two speed transmission (up to 5 km/hr). Combined with auto shift down function, the KC110HR-4 offers maximum traction force in tough conditions or when turning on the spot.



### Grease tension system

The rubber crawler is tensioned by a grease cylinder. This feature allows cushioning when foreign materials are going into the crawler. In addition, the short pitch track offers smooth drive for higher comfort for the operator.



### Maintenance

A large opening bonnet gives good access to the main areas for daily maintenance: fuel tank, air filter, engine oil level, reserve tank and battery isolator switch.

### Performance

The KC110HR-4 is the ideal workmate for a mini-excavator on a worksite. The crawler type transmission ensures good traction in all conditions while the ground pressure is minimal. The KC110-4 can easily avoid obstacles with a rear angle of gradeability of 28° and a ground clearance of 184.5 mm.



## SPECIFICATIONS

Model	KC110HR-4	
Engine	Make	Kubota
	Model	D722
	Output kW (PS) / rpm	11.8 (15.7) / 2550
	Displacement cc	719
	Cooling system	Water cooled
Service weight	kg	960
Max. loading capacity	kg	1000
Skip tipping system	Hydraulic	
Dumping direction	Rotary / 180°	
Dumping height	mm	495
Transmission	Type	Hydraulic
	Hydraulic pump	2 variable pumps
	Flow (for each pump) ℓ/min	2 x 29.2
	Hydraulic motors	Trasmital pistons motors
	Max. pressure bar	175
	Main valve	5
Dimensions	Overall length mm	2325 / 2075 (foot step up)
	Overall height mm	1470
	Overall width mm	990
Internal skip dimensions	Length mm	1300
	Width mm	890
	Height mm	605
	Dumping angle deg	90°
	Heaped volume m <sup>3</sup>	0.52
	Level volume m <sup>3</sup>	0.44
Undercarriage	Ground clearance mm	184.5
	Tumbler distance mm	1075
	Rubber shoe width mm	230
	Track roller	3
Travelling speed (Forward / Reverse)	1st speed km/h	0 ~ 2.6
	2nd speed km/h	0 ~ 5
	Max. gradeability	20°
Fuel tank capacity	ℓ	20
Hydraulic oil tank capacity	ℓ	25
Ground pressure	(Unloaded) gr/cm <sup>2</sup>	196
	(Loaded) gr/cm <sup>2</sup>	398

★ The data have been measured on the standard version. Specifications are subject to change without notice.

## DIMENSIONS

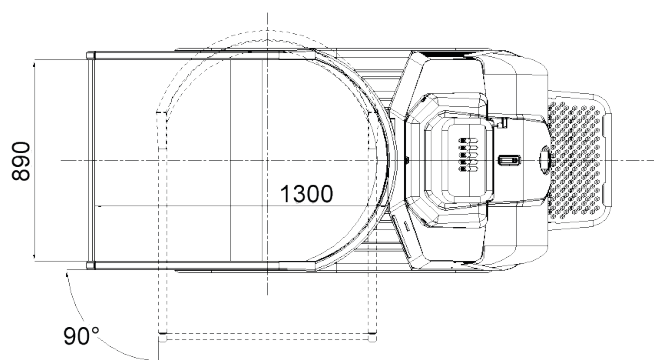
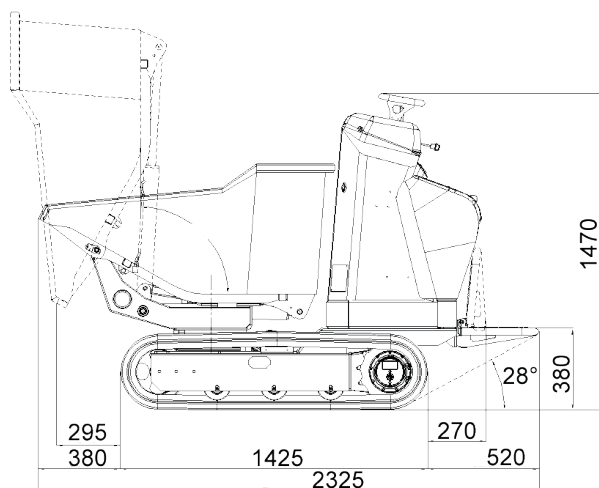
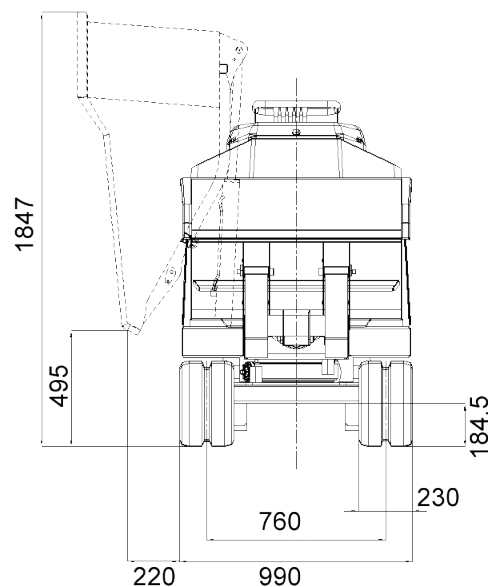

★ All image's shown are for brochure purposes only.

When operating the tracked dumper always wear proper PPE clothing and equipment in accordance to local legal and safety regulations.

### KUBOTA EUROPE S.A.S.

19 à 25, Rue Jules Verceyrysse  
Zone Industrielle - B.P. 50088  
95101 Argenteuil Cedex France  
Téléphone : (33) 01 34 26 34 34  
Télécopieur : (33) 01 34 26 34 99  
<http://www.kubota-global.net>

W21PS02301