

MANIACCESS

120 AETJ C 120 AETJ C 3D

Self-propelled electric articulating boom lift

- Working height : 11.95 m
- Maximum outreach : 7.00 m
- Up and over : 4.77 m
- Overall width : 1.20 m
- 3D option : Jib rotation



120 AETJ C Compact 120 AETJ C 3D Compact

	Working height	11.95 m
	Platform height	9.95 m
	Horizontal outreach	7.00 m
	Up and over height	4.77 m
	Jib movement	+70° / -70°
	Option 3D	+70° / -70°
	Basket rotation	140°
	Turret rotation	355°

	Platform capacity	200 kg/2 peoples
	External use	45 km/h (Maximum allowed wind speed)
	Basket size	1.20 x 0.92 m

	① Width	1.20 m
	② Length	5.48 m
	③ Stowed length (storage)	3.74 m
	④ Height	1.99 m
	⑤ Stowed height (storage)	2.16 m

	⑥ Turning radius inside	1.55 m
	⑦ Turning radius outside	3.25 m
	⑧ Turning radius outside (basket)	3.34 m
	⑨ Ground clearance	0.10 m
	⑩ Wheel base	1.65 m
	Drive speed	6.0 km/h
	Working speed	0.6 km/h

	Gradeability	25%
	Maximum slope accepted	5% or 3°

	Weight	6 660 kg
---	---------------------	----------

	Tires	0.60 x 0.19 m
	Wheel steer	2 (front)
	Wheel drive	2 (back)

	Batteries	240 Ah / 2x24 V
	Battery charger	30 Ah/48 V

Standard equipment

- Electrical battery traction
- Negative brakes
- Lifting brackets
- Hour meter
- Warning buzzer in the basket
- 220 V predisposal
- Voltage indicator
- Safety manual pump
- Basket with mesh floor
- Bus CAN technology
- Diagnostic help integrated
- Dual electrical motors
- Rubber and no marking tires
- Anti-roll system
- Integrated charger
- Toolbox in the basket

Options

- Jib rotation (3D)

- High capacity battery (300 Ah/2x24 V)
- Gel batteries
- Centralized filling of batteries
- Dual voltage charger 110 V / 230 V
- Working lights
- Electric plug in the platform with circuit breaker (230 V)
- Flashing light
- Drive alarm
- All motion alarm
- Console protective cowl
- Air predisposal
- Water predisposal
- Specific painting
- Biodegradable oil

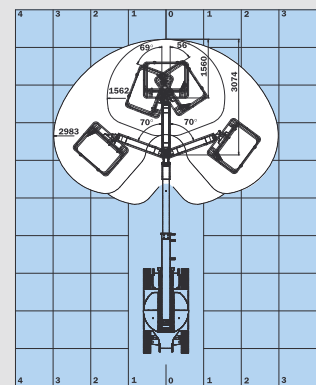
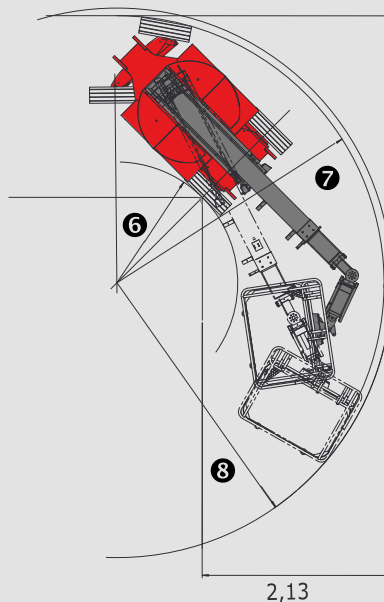
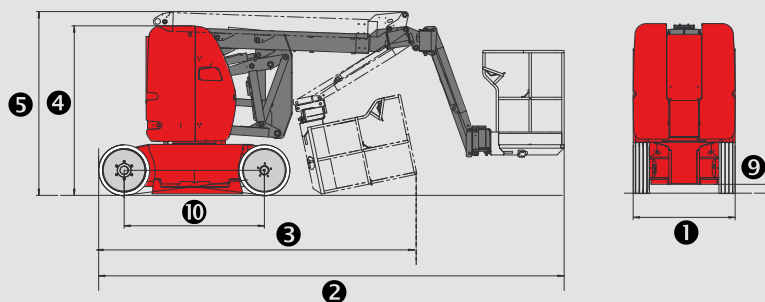
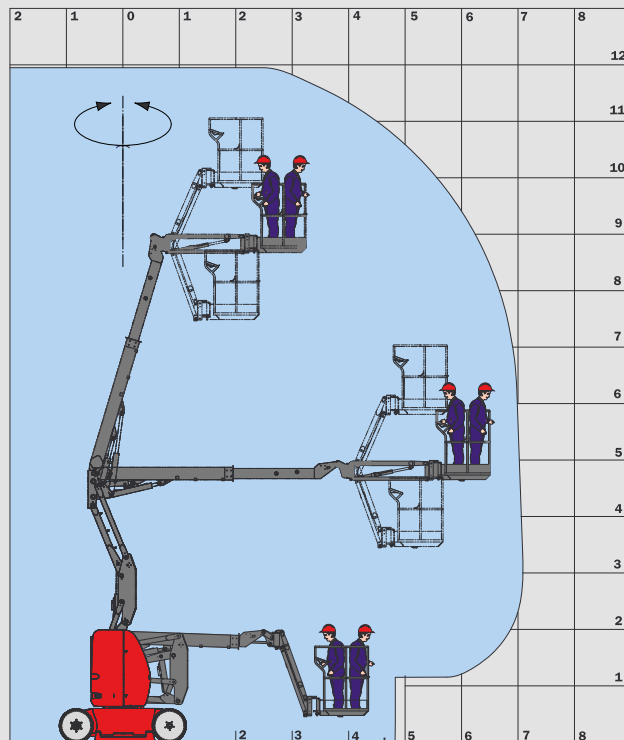

Option 3D : Jib rotation

The equipment supplied with each model may differ from that described in this leaflet.
For more details, contact your MANITOU dealer.



MANITOU BF SA

B.P. 249 - 44158 Ancenis Cedex - France
Tel. : 33 2 40 09 10 11 / Export Department Fax : 33 2 40 09 10 97
www.manitou.com

700364EN_B_0210_120AETJC.qxd

