



www.heatwork.com

HeatWork®

BRUKERMANUAL

HeatWork®

1. Introduksjon.....	4
1.1. HW Maskinene	4
1.2. Identifikasjon av maskinen	5
1.3. Sikkerhetsaspekter	5
1.4. CE-Merket	5
2. Oversikt	6
2.1. Beskrivelse HW Maskinene	6
2.2. Oversikt HW Maskinene.....	7
2.3. Oversikt Cummins Onan.....	7
2.4. Oversikt HW 1800	8
2.5. Oversikt styrepanel HW 1800.....	10
2.6. Oversikt HW 3600 Container.....	11
2.7. Oversikt HW 3600	12
2.8. Oversikt styrepanel HW 3600.....	14
2.9. Elektroskap	15
2.10. Dieseloelje	16
2.11. VTV-Væske.....	16
2.12. HW-Slange	16
2.13. HW Winter-Insulation.....	17
3. Bruksområder	18
3.1. Frostsikring og teletining	18
3.2. Vedlikehold og oppvarming.....	18
4. Tining av ulike masser	19
4.1. Generelt om tining.....	19
4.2. Slangeavstand	19
4.3. Spesielle tinemasser	19
4.4. Slangeutlegg og isolering	20
4.5. Tinehastighet og areal.....	20
4.6. Kontroll av tinedybde.....	21
4.7. Utleggsmønster og arealdekning	21
5. Sikkerhet	22
5.1. Personlig verneutstyr	22
5.2. Sikkerhetsanordninger	23
5.3. Nødstoppbryter	23
6. Klargjøring og transport	23
6.1. Klargjøring	23
6.2. Transport av HW maskinen.....	25
7. Prosedyre	26
7.1. Tilrigging og oppstart.....	26
7.2. Nedrigging.....	29
8. Overvåking under drift.....	31
8.1. Lokal overvåking	31
8.2. Justering drift	32
8.3. GSM Brukerveiledning.....	32
8.4. Innsetting av SIM-kort	32
8.5. Indikatorlys	32

8.6.	Varslingsmeldinger	32
8.7.	Servicemeldinger	33
8.8.	Legge til nye nummer	33
8.9.	Fjerne telefonnummer.....	33
9.	Indikatorer og feilmeldinger	34
9.1.	Indikatorer på styrepanel	34
9.2.	VTV nivåålass	34
9.3.	Feilsøking HW maskinene	35
9.4.	Feilsøking aggregat	35
9.5.	Feilsøking frekvensomformer	36
10.	Sommerlagring	41
11.	Garantier	41
11.1.	Vilkår for garanti	41
12.	Sjekk og vedlikehold.....	42
12.1.	Daglig sjekk.....	42
12.2.	Skifte av filter på VTV-system	43
12.3.	Skifte av dieselfilter brenner	43
12.4.	Vedlikehold av aggregat.....	44
12.5.	Lagring av maskin	44
12.6.	Tømming av dieseltank	44
12.7.	Utskifting av VTV-Væske	44
12.8.	Brenner.....	44
12.9.	Kjele.....	45
12.10.	Slanger	45
13.	Tekniske data	46
14.	MY35.....	48
14.1.	Oversikt HW MY35.....	48
14.2.	Oversikt styrepanel HW MY35	50
14.3.	Elektroskap HW MY35	51
14.4.	Bruksområder HW MY35.....	51
14.5.	Spesifikke sikkerhetsanmerkninger, HW MY35	51
14.6.	Transport av HW MY35.....	52
14.7.	Prosedyre.....	52
14.8.	Indikatorer og feilmeldinger.....	52
14.9.	Sjekk og vedlikehold.....	53
14.10.	Utskifting/etterfylling av VTV-Væske.....	53
14.11.	Tekniske data	54
15.	Vedlegg.....	55
15.1.	HMS Datablad VTV-Væske	55
15.2.	Brukerveiledning, Brenner: Riello DB4	55
15.3.	Brukerveiledning, Kjele: Atlas 95.....	55
15.4.	Brukerveiledning, Aggregat: Cummins Onan.....	55
15.5.	El Skjema.....	55

1. Introduksjon

1.1. HW Maskinene

For spesifikk informasjon, retningslinjer og sikkerhetsanmerkninger som gjelder MY35 se eget kapittel.

Typiske bruksområder for maskinene er tining av grunn, tining av grøfter, frostsikring og oppvarming av bygg der frost, fukt og temperaturer er en utfordring.

FrostHeater HW 1800 er en maskin for frost og teletining, betongherding og generelle varmejobber.

FrostHeater HW 3600/ HW 3600 Container har pumpekapasitet og kjele for ekstra store og krevende tinejobber. Kan tilkobles eksterne tromler for å doble tinearealet.

FrostHeater HW 3600 er maskinen som tiner raskest, også små områder.

HW maskinene anvender dieselforbrenning for oppvarming av sirkulerende varmevæske, og elektrisitet for drift av pumpe og styringssystem.

Maskinen er utrustet med to/tre parallellkoblede tineslanger å 315/210 meter. Slangene tromles motorisert på en hel eller tredelt slangetrommel. Maskinen og tineslangene er fylt og klargjort med varmetransporterende sirkulasjonsvæske.

Slangene legges ut på bakken med cc fra 0 til 60 centimeters avstand avhengig av tineareal og ønsket tineeffekt. Slangene dekkes med HW reflekterende isolasjonsmatt og HW Presenning for maksimal tineeffekt.

Trinnløs regulering av væsketemperaturen gir økonomisk og fleksibel bruk enten man skal tine eller frostsikre grunn.

Tilhenger modellene kan enkelt transporteres av kjøretøy med tillatt tilhengervekt på 2000 kg for HW1800/HW3600. Se spesifikasjonene i kap 14.1 for nærmere angivelse av maksimalvekt.

Container-modellene er klargjort med løfteører og gaffellommer for enkel flytting/transport.

Anvendelsesområder

- ✓ Tining av grunn
- ✓ Tining av rør
- ✓ Herding av betong
- ✓ Tørking av bygg
- ✓ Oppvarming med vifter
- ✓ Tining av snø og is på tak
- ✓ Frostsikring
- ✓ Tining av grøfter
- ✓ Drift av gulvvarmesystem

1.2. Identifikasjon av maskinen

På venstre rammevange foran på henger og på maskinrammen under brenneren, finner man maskinidentifikasjonen som angir serienr. Det 3-sifrede serienummeret oppgis alltid ved kontakt med leverandør for raskere hjelp.

Manufactured by:	HeatWork AS Skarvenesveien 6, 8514 Narvik, Norway
Year of manufacture:	<input type="text"/>
Serial number:	<input type="text"/>
Model:	<input type="checkbox"/> HW 3600 <input type="checkbox"/> HW 1800 <input type="checkbox"/> HW MY35 <input type="checkbox"/> HW PetroHeater <input type="checkbox"/> HW HydroHeater

CE

1.3. Sikkerhetsaspekter

Maskinens komponenter og tineslangene vil ha overflatetemperaturer som tilsvarer innregulert væsketemperatur. Det er fare for forbrenning hvis instruksene for bruk i denne manualen ikke følges.

Da maskinen forbrenner dieselolje både i kjele og evt aggregat avgis det varm eksosgass. Selve maskinheten skal aldri plasseres innendørs eller under tak pga fare for kvelning og evt. pipebrann. Det må vises forsiktighet ved den utvendige eksospipen pga fare for forbrenning.

Dieselfylling gjennomføres med samme aktsomhet som man ellers gjør ved håndtering av drivstoff.

Det er svært viktig at tineområdet og maskinen adgangssikres med sperreband for å hindre skader på personer og utstyr.

BEMERK

DET ER FOR ALT PERSONELL INVOLVERT I BRUK AV DENNE MASKINEN VIKTIG AT INSTRUKSJONENE I DENNE MANUALEN LESES OG FØLGES.

I denne bruksanvisningen vil følgende skilting dukke opp:



1.4. CE-Merket

HW maskinen er CE merket. CE symbolet finnes på maskinplaten og det medfølger en samsvarserklæring fra produsenten HeatWork AS.

BEMERK

For Norge: HW maskinen er definert som anleggsmaskin og trenger ikke å registreres hos biltilsynet i Norge. Utstyr kan ikke fjernes fra maskinen for å bruke tilhengeren til transport av tilfeldige gjenstander. Slik bruk KREVER at tilhengeren er registrert.

Andre land: Undersøk de særskilte nasjonale reglene for registrering og begrensninger mhp hastigheter før maskinen fraktes. HW maskinen er en anleggsmaskin og det vil kunne være nasjonale hastighetsbegrensninger ved frakt av hengeren i uregistrert tilstand. Ved slike begrensninger anbefales det å registrere maskinen.

2. Oversikt

2.1. Beskrivelse HW Maskinene

Driftskomponentene til maskinen er montert på en galvanisert maskinramme som er innfestet til en galvanisert boggitilhenger eller i en spesialtilpasset container.

Kapellet er produsert i helstøpt glassfiber.

HW maskinen leveres med en eller flere regulerbare sirkulasjonspumper avhengig av modell.

HW 1800 leveres med hel trommel og 2 slangekretser på 315 m som kan parallellkobles på uttakene ved siden av trommelen.

HW 3600 maskinen leveres med en standard tredelt slangetrommel. Trommelen har tre slangekretser på 210m som parallellkobles på styrepanelet.

De tre varmeslangene vil totalt dekke et tineareal på ca 130 m² ved en slangeavstand på 20cm og 200m² ved c/c 30 cm. Enkeltslanger vil dekke et tineareal på ca 43 m² ved tilsvarende slangeavstand.

Utlegg av varmeslanger, HW isolasjonsmatt og HW Presenninger utføres enkelt og raskt.

De originale varmereflekterende HW isolasjonsmattene gir systemet minimalt varmetap.

Maskinen er spesielt utviklet for store varme- og tinejobber hvor eksternt tilleggsutstyr kan tilkobles for å utnytte maskinen ytterligere. Dette gir blant annet mulighet for å tilkoble en eller flere eksterne tromler som utvider tinearealet.

Tineprinsippet for HW Maskinene

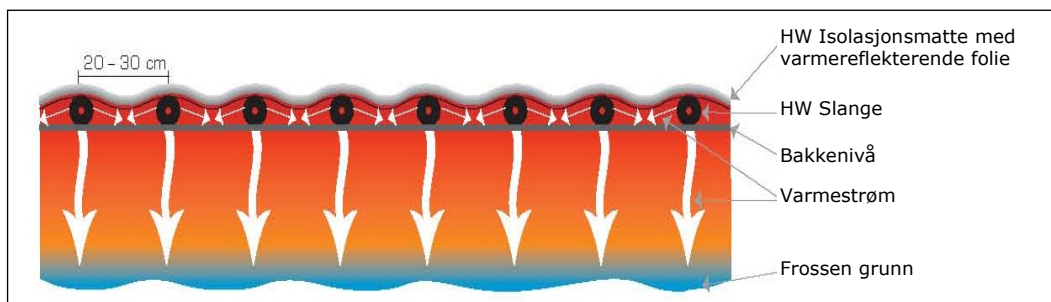

2.2. Oversikt HW Maskinene

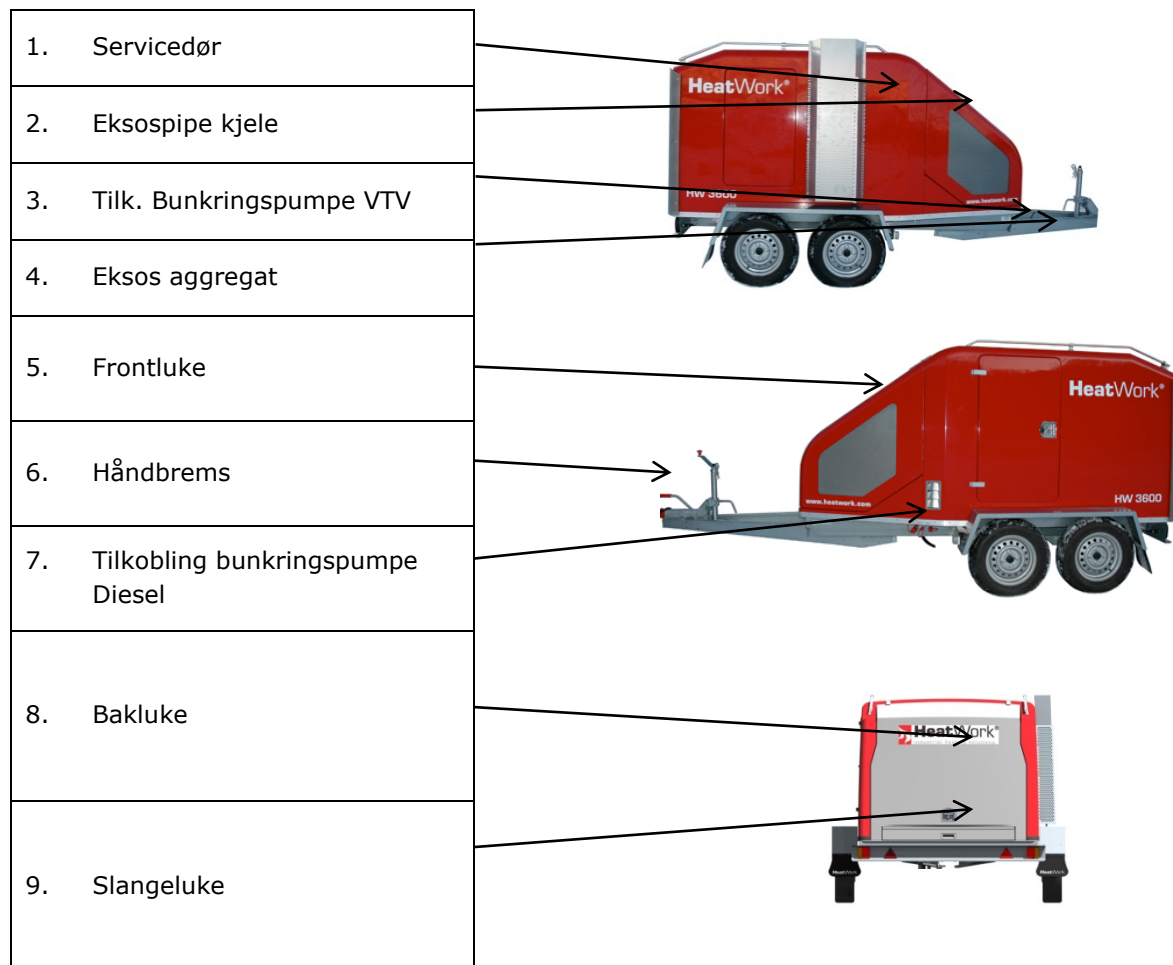

2.3. Oversikt Cummins Onan

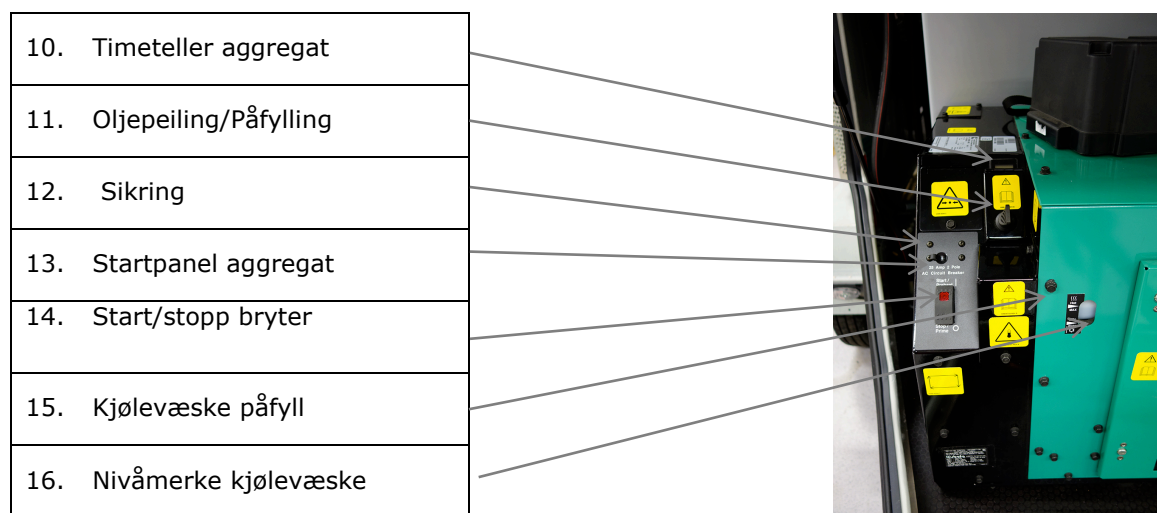

2.4. Oversikt HW 1800

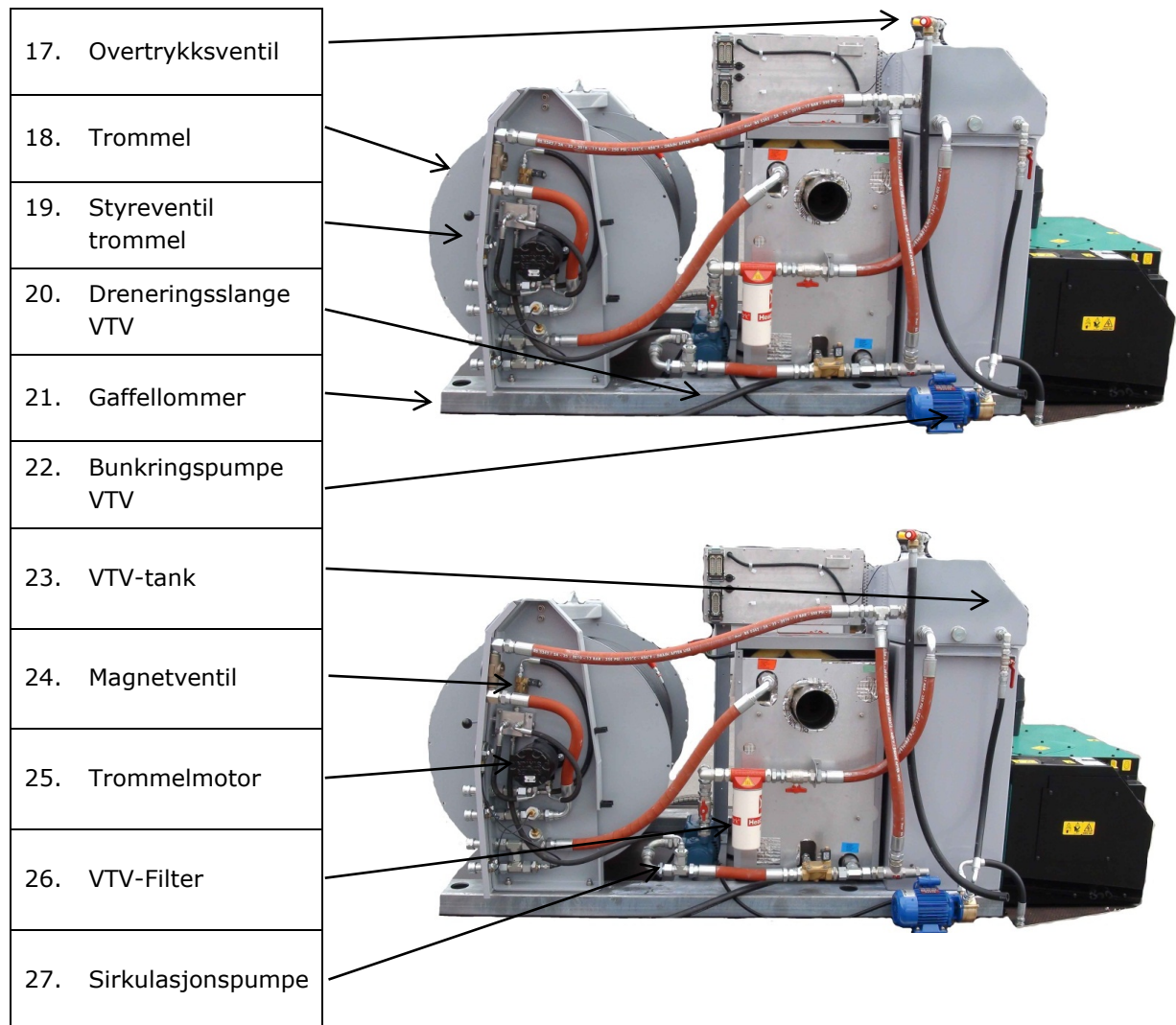

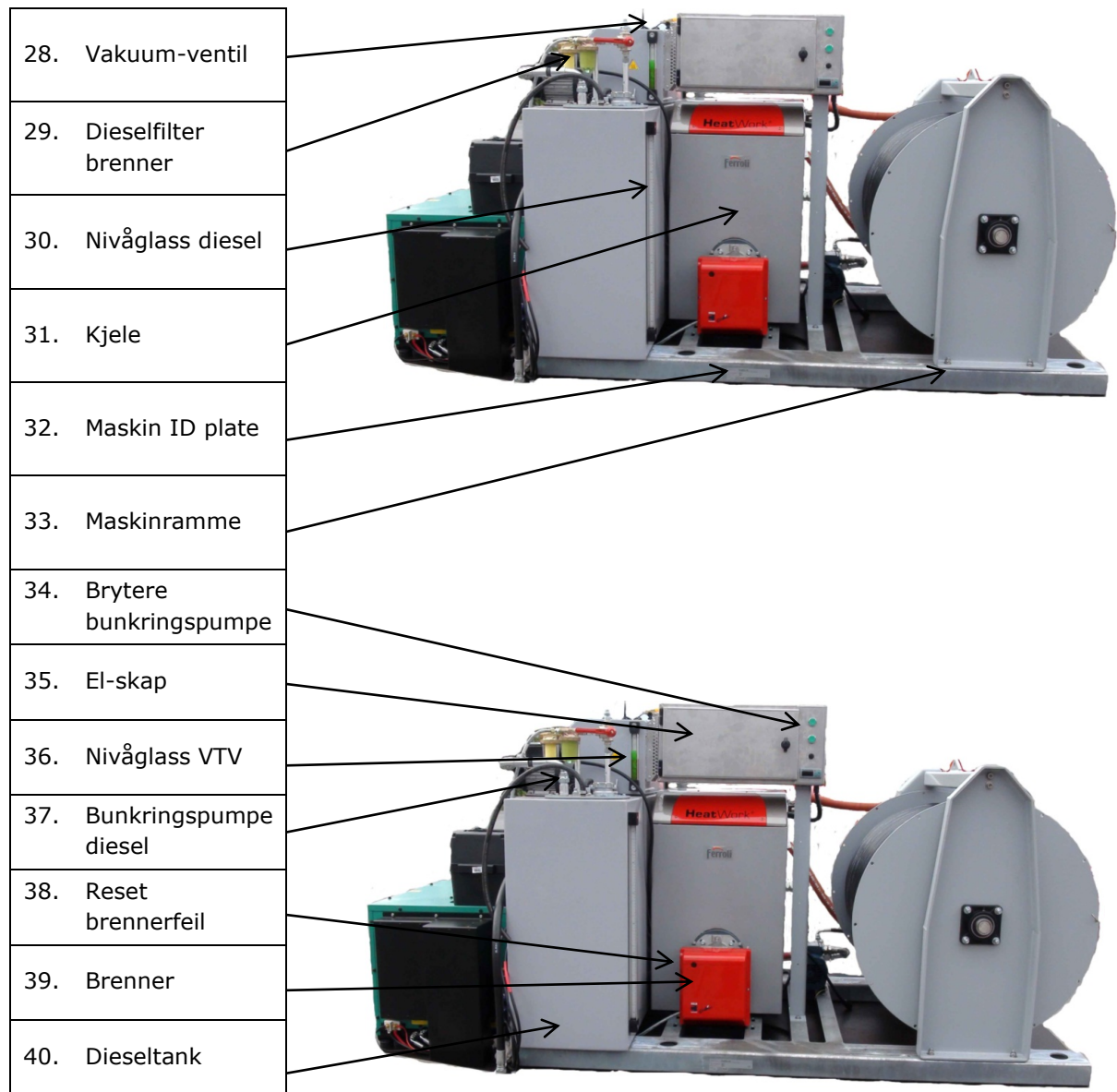

2.5. Oversikt styrepanel HW 1800

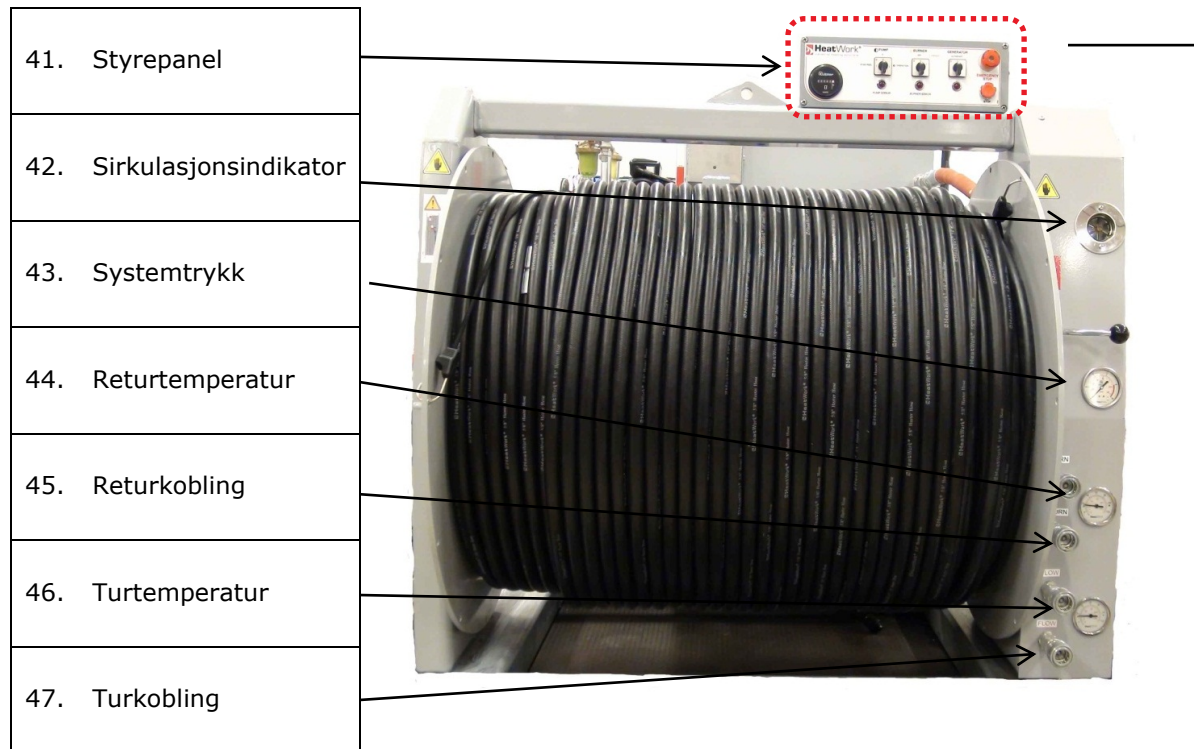

48. Timeteller sirkulasjon spumpe	49. Pumpe- bryter	50. Brenner- bryter	51. Start aggregat / autostart	52. Nød- stopp
---	----------------------	------------------------	--------------------------------------	-------------------

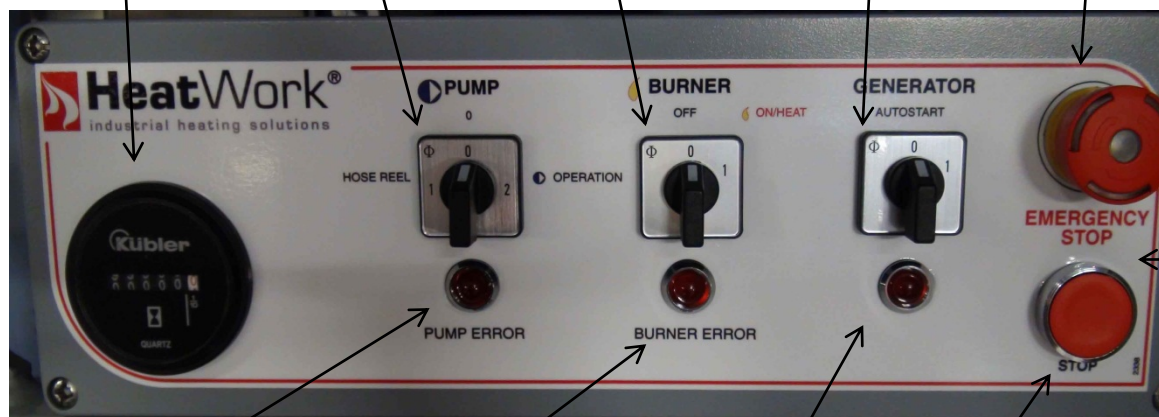

53. Pumpefeil- indikator	54. Brennerfeil- indikator	55. Indikatorlys aggregat	56. Stopp aggregat
-----------------------------	-------------------------------	------------------------------	--------------------

2.6. Oversikt HW 3600 Container

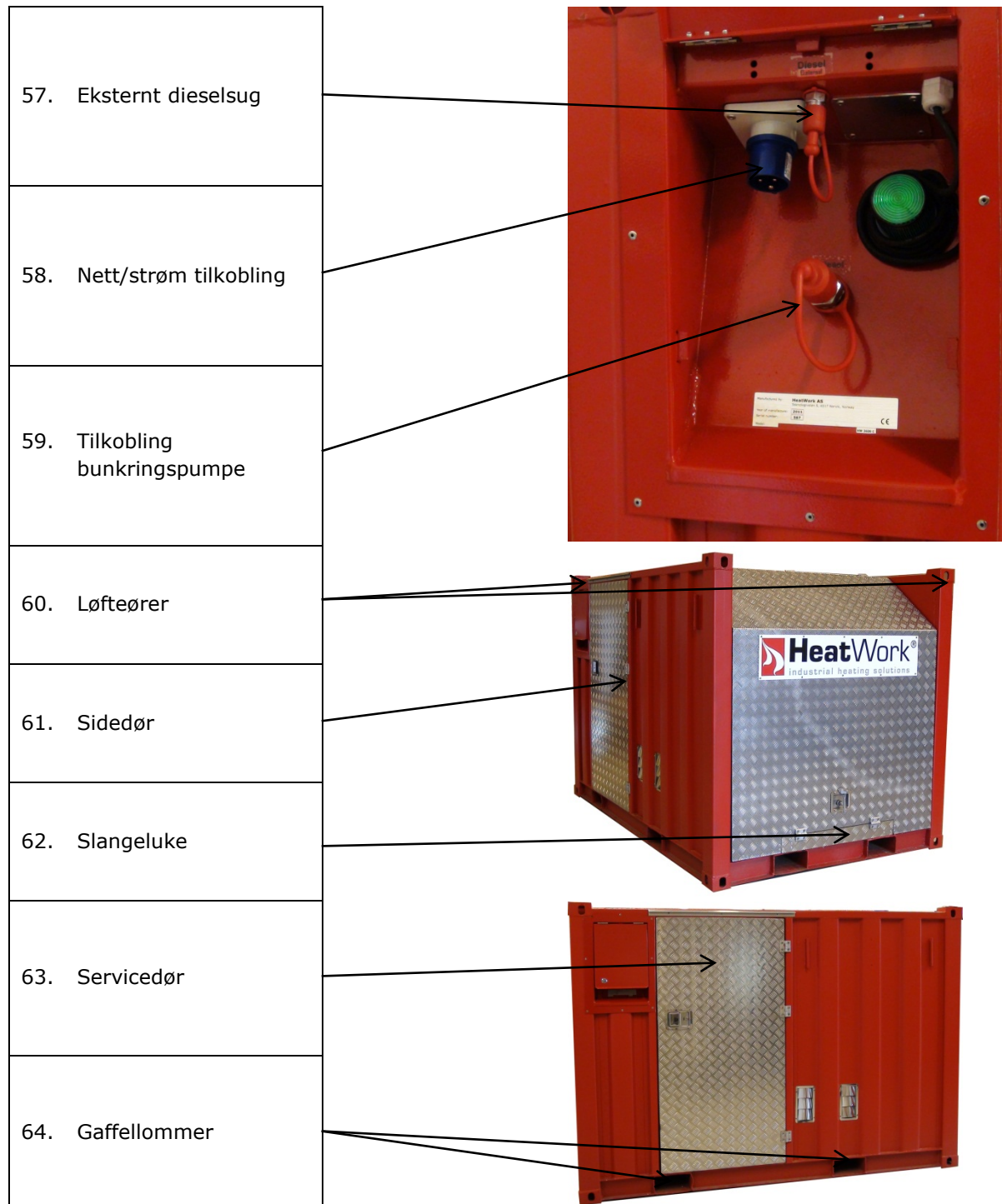

2.7. Oversikt HW 3600

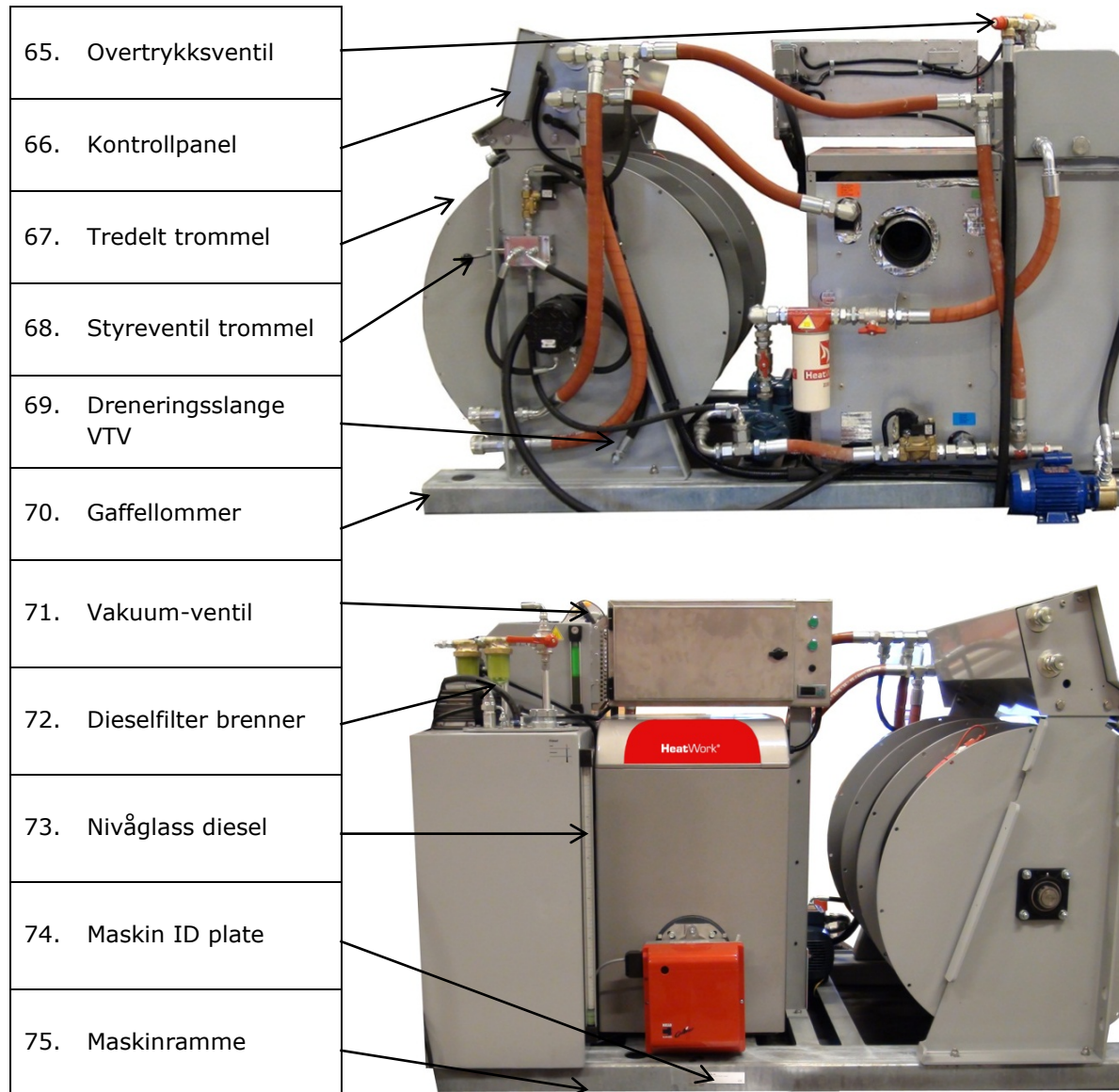

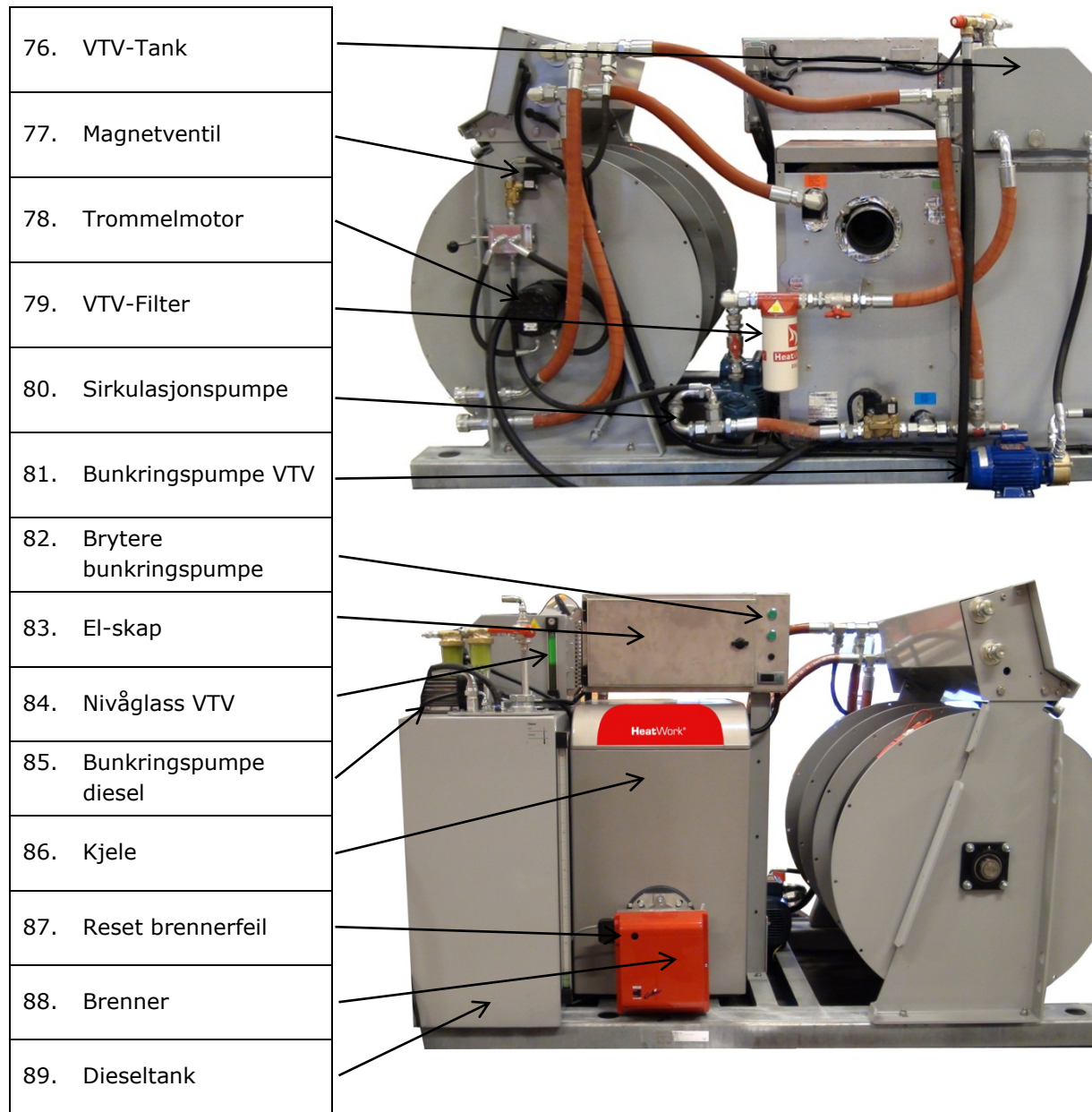

2.8. Oversikt styrepanel HW 3600

90. Returtemperatur ekstern	91. Systemtrykk	92. Returtemperatur tinekretser
-----------------------------	-----------------	---------------------------------

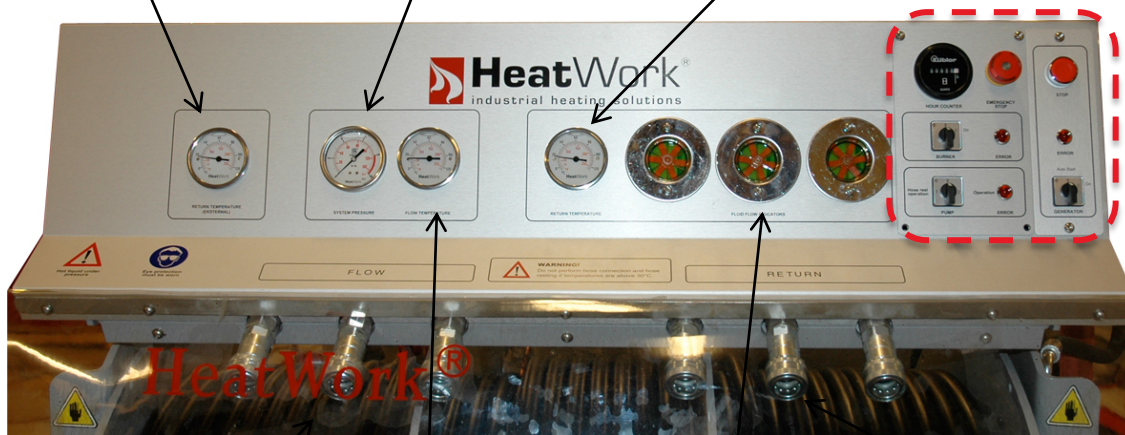

93. Turkobling	94. Systemtemperatur	95. Sirkulasjonsindikator	96. Returkobling
----------------	----------------------	---------------------------	------------------

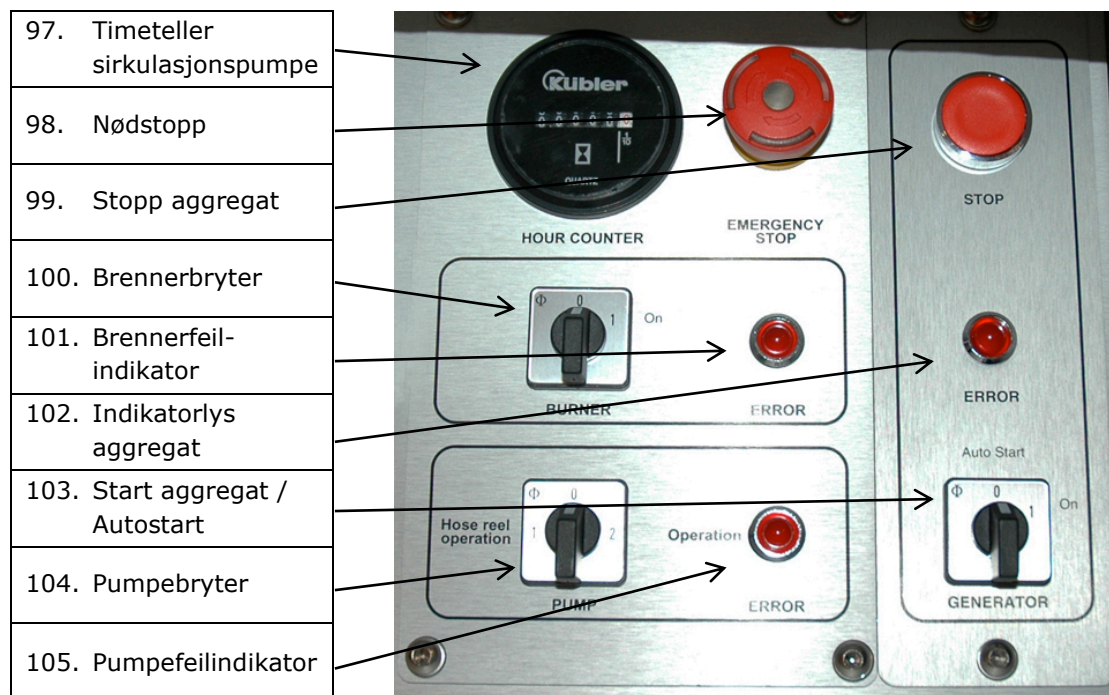

2.9. Elektroskap

106. Sikring pumpe (16A)	107. Sikring (6A) for brukere	108. Kontaktor brenner	109. Varsel-lys	110. Bunkrings-pumpe VTV	111. Bunkrings-pumpe diesel
--------------------------	-------------------------------	------------------------	-----------------	--------------------------	-----------------------------



112. Frekvens-omformer pumpe	113. Batteri (4A) DC	114. GSM-sender	115. Overopp-hetingssikring	116. Temperatur-regulering
------------------------------	----------------------	-----------------	-----------------------------	----------------------------

2.10. Diesellolje

HW bruker diesellolje for oppvarming av VTV væsken. Det anbefales å bruke vinterdiesel, Arktisk klasse 2 ved temperaturer under 0°C. Ved driftstemperaturer under -20°C skal det blandes parafin i dieselen i forholdet (3:1 Vinterdiesel/Parafin). HeatWork tar ikke ansvar for problemer som oppstår som følge av bruk av andre brennstoffer.

(Bruk av avgiftsfri diesel vil gi rimeligst mulig drift av HW maskinen.)

2.11. VTV-Væske

HW VTV-væske er tilpasset og testet for bruk i kombinasjon med HW maskinen. HeatWork AS anbefaler derfor HW VTV-væske. HeatWork tar ikke ansvar for problemer som oppstår som følge av bruk av andre VTV-væsker i sirkulasjonssystemet enn HW VTV- væske. Ytterligere utblanding av VTV-væske kan forårsake driftsforstyrrelser/problemer.

HW VTV-væske er merket som vist på siden.

BEMERK!

BRUK ALLTID HeatWork VTV Væske. Bruk av andre VTV-Væsker vil forårsake maskinhavari.



2.12. HW-Slange

HW 3600 leveres med totalt 630 meter varmeslanger. Trommelen er tredelt der hver slangelengde er 210 meter som gjør systemet fleksibelt i bruk.

HW 1800 leveres med totalt 630 meter slange. Trommelen er hel der hver slangelegde er 2x315 meter.

HeatWork tar ikke ansvar for problemer som oppstår som følge av bruk av andre typer slanger.



FARE

BRUK ALLTID HW-varmeslanger.

HW-Slanger er trykktestet og produsert i materialer til formålet. HAVARI ved bruk av uoriginale slanger kan medføre alvorlige forbrenningskader.

2.13. HW Winter-Insulation

Unik konstruksjon

De unike isolasjonsmattene minimerer varmetapet til omgivelsene i bruk sammen med HW maskinen. Den aluminiumsbelagte siden reflekterer strålingsvarmen fra bakken som gjør at denne type isolasjon egner seg til i bruk i utallige applikasjoner.

Materiale		3 og 7 lag lukket polymer celleskum
		1 lag reflekterende
Bredde/lengde		1,2 x 3 m (7 lag)
		1,2 x 6 m (7 lag)
		2 x 6 m (3 lag)
		2 x 12 m (3 lag)
Areal per matte		3,6 – 24 m ²
Total vekt per matte		2,1 – 9,6 kg
Produktets egenskaper		
Fukt		Tar ikke til seg fukt. Ingen kapillærsugende egenskaper; værbestandig
Holdbarhet		Endrer seg ikke ved anvendelse. Lang levetid.
Temperatur		Fleksibel selv i svært høye og lave temperaturer.

Bruksområder

- ✓ Isolasjon ved tining
- ✓ Frostbeskyttelse over nystøpte betongdekker
- ✓ Tildekking av forskaling
- ✓ Isolering av byggematerialer
- ✓ Isolering av utgravde tomter
- ✓ Grøfter m.m.



3. Bruksområder

3.1. Frostsikring og teletining

HW konseptet er den mest effektive måten å frostsikre og tine tele i grunnen. Slangene legges ut i mønster på ønsket areal som tildekkes med HW-Isolasjonsmatter. Nedenfor er noen eksempler for anvendelse av HW maskinene.

Tining av grunn for store og små arealer

- ✓ Vann og avløpsanlegg
- ✓ Kabelgrøfter
- ✓ Gruber, sokler og gulvarealer
- ✓ Tak og dekker
- ✓ Fjerning av is og snø
- ✓ Åpning av frosne vannveier
- ✓ Åpning av frosne stikkrenner

3.2. Vedlikehold og oppvarming

Etter at en tineprosess er gjennomført kan man om ønskelig regulere ned væsketemperaturen til vedlikeholdsvarme for å hindre ny frostnedtrenging. Dette minimerer varmekostnadene til et minimum. Innstilt vedlikeholdstemperatur er avhengig av utetemperaturen og varmearealet.

Frostfrie

- ✓ Belegningsarealer
- ✓ Sandmasser, settesand
- ✓ Omfyllingsmasser
- ✓ Rørgater
- ✓ Sporvekslere
- ✓ Flytebrygger
- ✓ Byggegrunn

Oppvarming av

- ✓ Arbeidstelt
- ✓ Brakker
- ✓ Lager og brukshaller
- ✓ Bygg

Forvarming av

- ✓ Grunnarealer for støyping
- ✓ Forskalinger og betongarbeider
- ✓ Uttørking av betong og hulldekkelementer

Kontakt HeatWork AS for eventuelle spørsmål.

4. Tining av ulike masser

4.1. Generelt om tining

HW maskinene har en tinekapasitet på 10-60 cm pr. døgn. For normale masser er tinehastigheten typisk 20-50cm, men denne vil variere sterkt avhengig av jordart, vanninnhold i jorden, slangeavstand og utetemperatur. Tinehastigheten reduseres først og fremst ved økende vanninnhold/is i bakken. Relativ tinehastighet er vist for 9 forskjellige jordsmønn i grafen til høyre.

Den viktigste maskinparameteren som innvirker på tinehastigheten er væsketemperatur og slangeavstand.

Brukermessig er måten slangeutlegget og isoleringen gjøres på, kritisk for å sikre god tining.

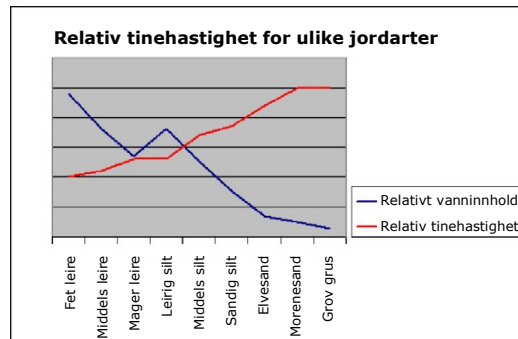

4.2. Slangeavstand

Mindre avstand mellom varmeslangene gir økt tineeffekt (W/m^2). Selv om 10-30cm slangeavstand som regel er tilstrekkelig, bør slangene alltid legges så tett som mulig hvis man ønsker rask tining og har tilstrekkelig slange tilgjengelig på et lite tineområde.

Skal areal på over 300m² tines simultant vil slangeavstanden være ca 50cm. I dette tilfellet vil det etter tining fortsatt kunne være frostsoner i overflaten mellom slangene. Lenger ned vil massen likevel være fulstendig tinet. Slike frostsoner i overflaten knekkes enkelt av gravemaskin ved utgraving. Beregn god tid på tinejobben når slangeavstanden er så stor som dette.

4.3. Spesielle tinemasser

Leire og Jord

Leire og jord er masser med typisk vanninnhold på 27-50%. Myrmasser vil kunne ha enda større vanninnhold. Da is-tining er energikrevende gir slike masser spesielt treg tining. Brøyt all is og sne bort fra overflaten og legg slangene så tett som mulig ved tining av slike masser. Tinehastigheten for disse massene er typisk 10-30cm pr døgn.

Grov grus og pukk

Svært drenerende jordarter som grov grus og pukk er vanskelig å tine da det er liten kontaktoverflate mellom partiklene. Det anbefales derfor å fjerne isolasjonen og tilføre vann etter en dags tining på hele tineområdet. Dekk deretter til slangene på nytt og fortsett tining. Dette vil gi vesentlig raskere tinehastighet. Sne og is som ligger på området før det startes å tine bør av denne årsaken ikke fjernes. Det tinede vannet fra isen vil sørge for rask tinetid pga økt varmeledning i massene.

Is og sne på bakken

Ren is er svært energikrevende å tine. Det kreves eksempelvis like mye energi å tine 10cm ren is som å tine 30-40cm sandig silt med 15% vanninnhold. Beregn derfor en ekstra dag tining hvis tineområdet har 10cm overflateis som ikke kan fjernes før tining.

4.4. Slangeutlegg og isolering

Unøyaktighet med utlegg av slanger og tildekking med isolasjon er en typisk brukerfeil som resulterer i vesentlig redusert tineeffekt.

Da varmen kanaliseres direkte fra slangene og ned i bakken er det svært viktig at slangene legges slik at de har god kontakt med bakken. Den oppvarmede luften under isolasjonsmattene gir hovedsakelig økt varmetap til luften.

HW-isolasjonsmattene legges med en overlapp på 30cm slik at varmetapet til luft blir minimalt. Sikre mattene med planker eller liknende som hindrer mattene å blåse av ved vind.

Varmeslangene bør alltid legges 0,5-1m utenfor det ønskede graveområdet på alle sider. Isoler gjerne opptil en meter ekstra utenfor slangearealet. Se illustrasjon i marginen.

Ved smale tinefelt transporteres mye varmeenergi ut til sidene og gir derfor redusert tinedybde. Legg derfor varmeslangene ekstra langt utenfor selve graveområdet.

Bruk av uoriginale isolasjonsmattene gir økt varmetap til luften og redusert tineeffekt.

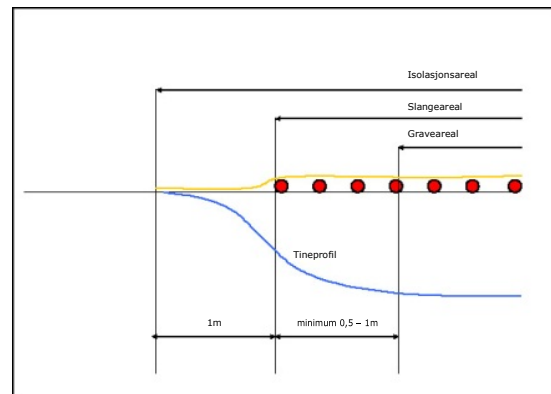

4.5. Tinehastighet og areal

Tinehastighet og tineareal med 630 m slange		
Slangeavstand (cm)	Arealdekning (m ²)	Tinehastighet
5	32	Rask tining
10	64	
15	97	Normal tining
20	129	
25	162	
30	194	
35	226	Treg tining/ frostsikring
40	259	
45	291	

Beregning av slangeavstand, tineareal og slangelengde

- 1 slange = 210 meter
- 2 slanger = 420 meter
- 3 slanger = 630 meter

Tineareal kapasitet

Maksimalt tineareal beregnes med gitt slangelengde og ønsket slangeavstand:

$$\text{Tineareal} = \text{Total slangelengde} \times \text{Slangeavstand}$$

Nødvendig slangeutlegg

Nødvendig total slangelende for å tine et gitt område med en gitt slangeavstand:

$$\text{Total slangelengde} = \text{Tineareal} / \text{Slangeavstand}$$

Nødvendig slangeavstand

Slangeavstand beregnes ut fra det gitte arealet og den totale slangelengden:

$$\text{Slangeavstand} = \text{Tineareal} / \text{Total slangelengde}$$

Eksempel

Man ønsker å dekke ca 150m² med den totale slangelengden på 630m. Hvilken slangeavstand skal man bruke for å dekke det ønskede arealet?:

Total slangelengde = 150 / 630 = 0,238m

Slangeavstanden kan maks være 24cm.

NB! Dekningsarealet må alltid være litt større enn gravearealet.

Hvis man ønsker raskere tining bør man vurdere å tine feltet i 2 omganger slik at det siste området tines mens man graver ut det første.

4.6. Kontroll av tinedybde

Kontroll i bakken for å sjekke hvor dypt det er tint kan gjøres enklest med gravemaskin eller ved å slå ned ett spett eller et spyd.

Vis forsiktighet hvis det skal graves i nærheten av varmeslangene slik at slangene ikke skades.



FARE

Under kontroll av tinedybde må området være tilstrekkelig opplyst for å unngå at slanger blir kappet ved uhell. Meget varm VTV Væske vil strømme ut hvis slanger blir kuttet under drift og kan medføre personskade.

4.7. Utleggsmønster og arealdekning

Eksemplene under siden viser hvordan slangene kan legges i sløyfemønster.

Mønstrene vil variere fra jobb til jobb. Det er viktig at man planlegger hver jobb og posisjonerer hengeren optimalt slik at utlegg av slanger blir enklest mulig og at man rekker frem til det arealet det skal legges slanger ut på.

Ved små tinefelt er det svært gunstig å bruke et sirkulært utlegg hvor man legger slangene helt inntil hverandre som vist i illustrasjon 3 nedenfor .

Desto dypere telen er, desto lenger utenfor selve graveområdet må slangene legges.

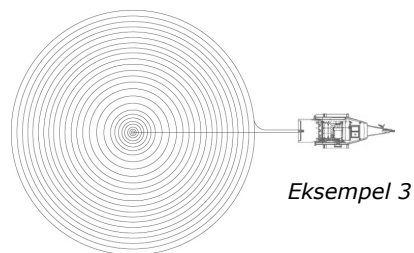
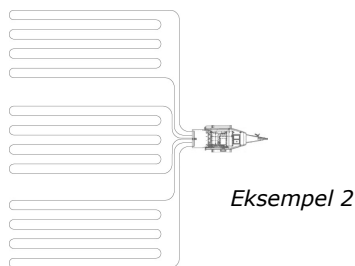
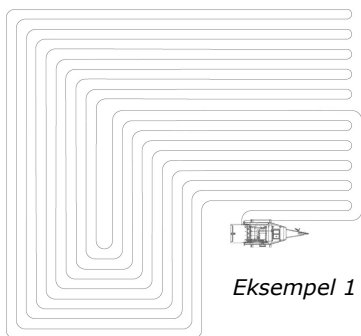

5. Sikkerhet

HW maskinen anvender diesel som oppvarmingskilde til tineslangene og elektrisitet for drift av pumpe og styringssystem. Diesel er antennbart og må derfor behandles med forsiktighet.

Det vil under normal drift være overflater som har høy temperatur. Når HW maskinen igangsettes skal operatøren være til stede ved maskinen til systemet har oppnådd driftstemperatur. Operatøren skal under oppkjøring av systemet inspisere koblinger, ventiler, etc. og forsikre seg om at systemet er tett og fri for lekkasjer og at det ikke er andre unormale tegn ved maskinen.

5.1. Personlig verneutstyr

Under drift vil VTV-væsken kunne ha en væsketemperatur på opptil 115°C. Ved arbeid med en slik høy temperatur er det viktig at operatøren tar forholdsregler om bruk av personlig verneutstyr. Det anbefales at operatører alltid bruker arbeidstøy som er godkjent for varme arbeider, vanntette arbeidshansker, vernesko og arbeidshjelm under arbeidsoperasjoner med HW maskinene i tillegg til de påbudte vernebrillene.



**Øyevern
påbudt**



**Varm væske
under trykk**

Det oppfordres at operatøren har med i trekkvognen/arbeidsbilen, eller på et annet oppvarmet sted i maskinens nærhet, et sett førstehjelpsutstyr og øyeskyll. Dette må av naturlige årsaker oppbevares frostfritt og lett tilgjengelig. Dette er særdeles viktig ved tining på steder hvor vann ikke er lett tilgjengelig. Se vedlegg for HMS datablad for HW VTV-væske.



FARE

For å unngå uønsket kontakt med varm VTV-Væske er det VIKTIG at alle komponenter i sirkulasjonssystemet vedlikeholdes og kontrolleres jevnlig.



ADVARSEL

Det anbefales at vernesko, arbeidsdress, hansker og hjelm benyttes ved operasjon av HW-maskiner, i tillegg til PÅBUDTE VERNEBRILLER.

5.2. Sikkerhetsanordninger

HW maskinene er utstyrt med automatisk stoppfunksjon på sirkulasjonspumpen som vil stoppe ved eventuelt slangebrudd eller tap av VTV-væske av andre årsaker. Stoppfunksjon aktiveres når VTV tanken har nådd et vist minimumsnivå. Maksimum VTV-væske som vil gå tapt til omgivelsene er ca. 30 liter. Varmevæsken som benyttes er ikke miljøskadelig. Ved maksimal pumpekapasitet vil det sprøytes ut under 1 liter VTV-Væske per sekund.

Kjele er utstyrt med overopphetingsvern som slår av brenner når temperaturen har overskredet et sikkerhetsnivå. Denne må resettes hvis dette har hendt.

PVC-duk på styrepanel må alltid henge over slangene når maskinen er i drift.

Ved konstant brennerdrift må brenner stoppes 5min/ 24 timer.

5.3. Nødstoppbryter

Maskinen er utstyrt med nødstoppbryter for bruk ved eventuelt farlige situasjoner som kan oppstå i forbindelse med slangelekkasje og tromling.

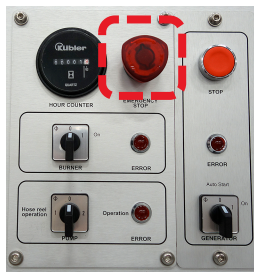

6. Klargjøring og transport

6.1. Klargjøring

Før oppstart er det viktig at man utfører en kontroll, slik at utstyret er klargjort før man transporterer til arbeidsområdet. Dette er viktig da man ofte vil oppleve kalde forhold hvor man bør unngå operasjoner som kunne vært gjort på forhånd. Nedenfor er viktige punkter som bør sjekkes før transport til arbeidssted.

Lufttrykk, lys, brems

Sjekk lufttrykk i dekkene på tilhengeren før transport. Sjekk at trafikklys og arbeidslys virker som de skal. Sjekk trafikklysene på hengeren når strømkontakt fra trekkvogn er tilkoblet. Sjekk innvendig arbeidsbelysning. Sjekk at håndbrems er tilstrekkelig stram og at den fungerer som den skal. Avvik rettes opp før transport av HW maskinen.

Fylling av diesel og VTV-Væske

Diesel og VTV-væske kan fylles/etterfylles der bruk av HW maskinen skal foregå. Imidlertid bør fylling/etterfylling foregå før man transporterer HW maskinen til arbeidsområdet. I noen tilfeller kan transport med tom dieseltank være hensiktsmessig ved lengre transportetapper.

Sjekk alltid nivåglass for diesel **(A)** og VTV-væske før oppstart **(B)**.

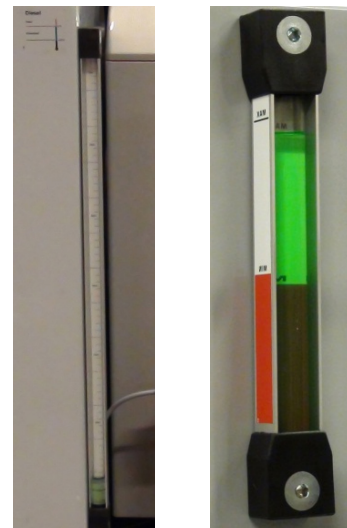

A

B

MANUELL FYLLING AV DIESEL

Ved manuell fylling observeres nivåglass på dieseltank. Stopp manuell fylling før tanken blir overfylt.

Ved driftstemperaturer under -20°C skal det blandes parafin i dieselen i forholdet (3:1 Vinterdiesel/Parafin).

Fylling av diesel med bunkringspumpe

Bunkringspumpeslange kobles til venstre hurtigkupling **(A)**.

For container se bilde **(B)**.

Plasser slangen godt ned i dieseltank.

Hold inne knapp for bunkringspumpe, på el-skap **(C)**.

Når nivå er på max, slipp knappen. Pumpen stopper.

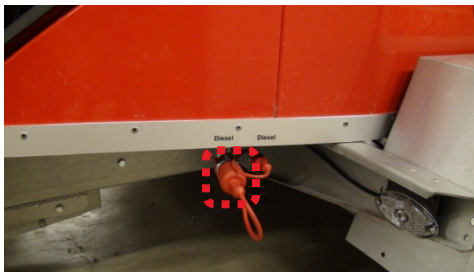

A



B



C

TILKOBLING TIL EKSTERN DIESELTANK

Alle HW maskinene har mulighet for å suge direkte fra en ekstern tank for å øke ubemannet driftstid. Vri kranen på inspeksjonslokk til vertikal posisjon **(D)**. Tilkoble medfølgende sugeslange (5 meter) til høyre hurtigkupling på maskinen **(E)** og andre enden til ekstern tank. Sørg for å tørke av smuss på slangenippelen før tilkobling.

For container se **(F)**



D



E



F

Fylling av VTV-Væske

Fylling av VTV-væske skal kun foregå når denne er under 45°C. Det skal kun benyttes væske av type HW VTV-væske. Bruk av andre typer væsker eller blandingsforhold vil føre til driftsforstyrrelser/ problemer. Garantien gjelder ikke i slike tilfeller. Maskinen er utstyrt med slange til bunkringspumpe, som er lokalisert foran i aggregatrommet.

Bunkringspumpeslange kobles til hurtigkupling på høyre side av maskinen. **(G)**

Plasser slangen godt ned i VTV-dunken. Åpne kranen, **(H)**.

Hold inne knapp for bunkringspumpe på el-skap **(I)**.

Når nivå er på max, slipp knappen og pumpen stopper.

Steng kranen **(H)** etter fylling.

Tømming av VTV-Væske skjer gjennom dreneringsslange VTV.



G

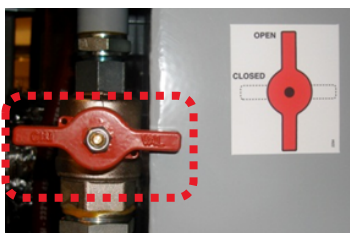

H



I

6.2. Transport av HW maskinen

Transport av maskinen skal skje med kjøretøy som har tillatt tilhengervekt over den oppgitte maksimalvekten i kap 14.1. Valg av trekkvogn må vurderes mot de veiforholdene der transporten skal foregå. HW maskinene er standard utstyrt med helårsdekk.

Kontroller overensstemmelse med særskilte nasjonale regler før transport.



Transport av HW 3600 FrostHeater

7. Prosedyre

Denne seksjon tar for seg trinn for trinn hvordan korrekt drift av HW maskinene skal foregå. Prosedyren under tar for seg fra maskinen er parkert, til en tinejobb er utført og maskinen rigget ned.

7.1. Tilrigging og oppstart

Før man legger ut varmeslanger og matter bør det aktuelle området sikres med sperrebånd slik at man unngår at anleggsmaskiner eller andre kjøretøy gjør skade på utstyret som legges ut på bakken.

Nett/strøm-tilkobling – Autostart strømaggreat

Hvis nettstrøm velges, plugges den medfølgende skjøteledningen til nettet og siden til apparatintaket ved siden av styrepanelet. Ved å sette autostartbryteren til (ON) vil strømaggreatet starte automatisk ved bortfall av nettstrøm. Når nettstrøm kommer tilbake vil maskinen registrere dette og stoppe aggregatet etter noen minutter. Maskinen vil da gå på nettstrøm. Ved stopp av maskinen må autostartbryter settes til (0) for at strømaggreatet ikke skal starte automatisk.



J



K

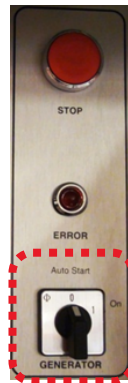

L



Spesielt viktig at jordspydet er satt i bakken for jording av maskin

Tilkobling til ekstern dieseltank

Maskinene kan kobles til en ekstern dieseltank for økt ubemannet driftstid.



FARE

Selve maskinenheten skal aldri plasseres innendørs eller under tak pga fare for kvelning og pipebrann.

Innstilling for uttromling

Manuell uttrekk

I tilfeller med kun en operatør, anbefales det å manuelt dra varmeslangene ut av trommelen for å unngå slakk og dermed "stuing". Følge Reguleringskranen settes i nøytral posisjon (Horisontalt).

Motorisert Uttrekk

I tilfeller med 2 operatører kan sirkulasjonspumpen brukes til å drive trommelen.

Hastigheten styres da av en person, mens en annen person legger varmeslangene på tinearealet. Følgende prosedyre følges:

- Sett sirkulasjonsbryteren til posisjon "Trommeldrift"
- Hastighet på trommelen reguleres med reguleringsspaken.



Klemfare

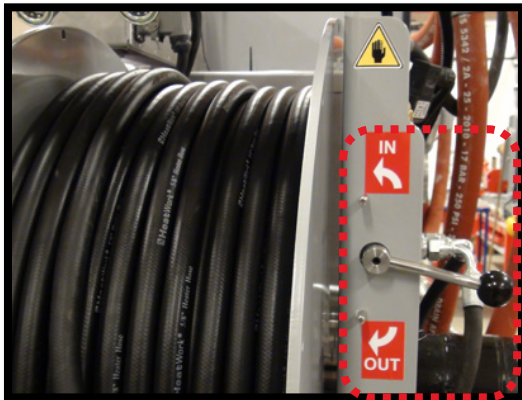

HW 3600

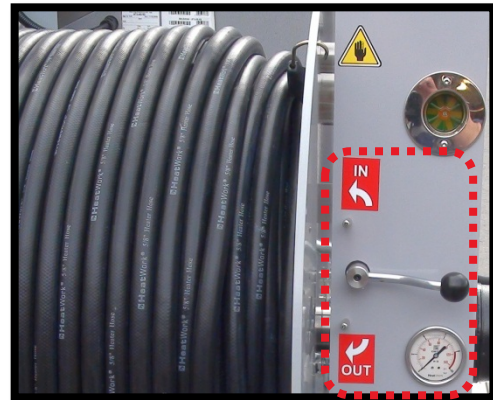

HW 1800

Uttrekk av slanger

Varmeslangene bør trekkes/kjøres ut en om gangen. Slangene koples til maskinen når ønsket antall kretser er trukket ut. Husk ikke å blande endene på kretsene ved påkopling til maskinen.

Utlegg av slanger på bakken

Søk å få best mulig bakkekontakt med varmeslangene og unngå å legge slangene på skarpe gjenstander. Slangeavstanden velges ut fra ønsket tinehastighet og ønsket tineareal. Se foregående kapittel for detaljer om tinehastighet, arealdekning og slangeavstand.

Kobling av slanger

Tørk av smuss på slangekoblingene før tilkobling til manifolduttakene. Sjekk at koblingene sitter som de skal slik at de ikke løsner ved pumpestart. Sirkulasjonspumpen skal være avslått ved montering/demontering av slangenens hurtigkoblinger.

Slangeendene er fargekodet. En ende til tur, og den andre til retur.

Start sirkulasjonspumpe

Sirkulasjonspumpen startes alltid før brenneren startes. Sirkulasjonsbryteren settes til posisjon "Operation".

BEMERK!

UNNGÅ i mest mulig grad å la innvendige deler i slangekoblinger komme i kontakt med jord og sand slik at forurensninger kan komme inn i VTV systemet.

BEMERK!

Sirkulasjonspumpen må startes før BRENNEREN startes. I motsatt fall vil ikke BRENNER starte.

Innstilling av væsketemperatur og start av brenner

HW maskinene leveres med digital termostat for regulering av væsketemperaturen.

Før brenneren startes settes væsketemperaturen på kjelepanelet til ønsket temperatur. Maksimal tillatt væsketemperatur på HW 1800 og HW 3600 er 100°C.

Start av brenner

Brenneren startes ved å sette brennerbryteren på kontrollpanelet til posisjon 1. Brenneren vil da starte etter noen sekunder. NB; sirkulasjonspumpen må startes før brenneren startes.

Kontroll av sirkulasjon og trykk

Hver sirkulasjonskrets i systemet har separat strømningsindikator. Kontroller at disse roterer i den eller de respektive sirkulasjonskretsene som er i bruk. Kontroller videre at det ikke er lekkasjer i koblinger, slanger eller i koblinger på maskinen. Dette gjøres før isolasjonsmatter legges ut slik at man har oversikt over utlagte slanger.

Kontroller alltid systemtrykk ved oppstart og jevnlig under tineprosessen. Normalt vil dette være høyt i starten og gå ned med økende væsketemperatur og antall påkoblede slangekretser.

Sjekk hastigheten på strømningsindikatorerne for å kontrollere at det sirkulerer i alle påkoblede slangekretser.

Ved stopp i strømningsindikatoren er det knekk på aktuell slangekrets.

Normalt driftstrykk er 2-6 bar.



STRØMNINGS-
HASTIGHET

Utlegging av isolasjonsmatter

Etter at sirkulasjon har startet legges HW-isolasjonsmatter ut over de utlagte slangene. Mattene skal ha en overlapp på minimum 30cm. Det anbefales at mattene legges en halv meter utenfor slangene rundt tinearealet.

Den varmereflekerende aluminiumssiden skal alltid vende ned mot slangene. Unngå å trekke isolasjonsmattene etter bakken med aluminiumssiden ned. Dette vil over tid forringe isolasjonseffekten.

Isolasjonsmattene kan sikres mot vind ved å bruke HW Presenninger. Unngå skarpe gjenstander slik at mattene ikke skades.

BEMERK!

UNNGÅ å slepe isolasjonsmattene med aluminiumssiden ned mot bakken. Dette medfører unødig slitasje.

7.2. Nedrigging

Nedkjøling før inntromling

Når en tinejobb er ferdig skal det foretas nedkjøling av VTV-Væsken før inntromling. Dette gjøres ved å slå av brenner og la sirkulasjonspumpen gå til 30°C er oppnådd på turvæsken.

Kaldere væske gir sterkere inntromlingsmoment på trommelmotoren.

Driftslys for lokal overvåking

Maskinene leveres med driftslys på taket for lokal overvåking og varsel om at maskinen er i drift. Lyset blinker grønt ved normal drift. Slukket lys indikerer driftsstopp eller avslått maskin.

Inntromling

NB: Utvis forsiktighet ved inntromling. Det er klemfare mellom trommelen og vangene. Forsøk aldri å stanse trommelen for hånd. Behold avstand fra trommelen under inntromling slik at hender eller handske ikke hektes mellom slangene eller til trommelstrikkene.

Når væsketemperaturen er sunket til under 30°C, kan inntromling av slanger foretas. Slå av sirkulasjonspumpe og koble endene fra manifolduttakene. Sett straks på beskyttelses-hettene på slange endene. Koble den ene slangeenden til en av trommelkrokene med enden vendt oppover. Tromle kun en slange om gangen.

Pumpebryteren settes til posisjon "trommeldrift". Trommelhastigheten reguleres så ved hjelp av reguleringsventilen. Operatøren må holde slangen under innkjøring og føre slangen for hånd slik at slangen pakkes best mulig på trommelen slik at det blir minst mulig slakk på slangen. Hansker eller en fuktig klut bør brukes for å dra av smuss på slangene under innkjøring. Operatøren tar kontroll på styrehendel når enden av slangen nærmer seg trommelen slik at siste fase av inntromling foregår sakte og kontrollert.

Monter til slutt de originale festestrikkene til slangeendene og hullene i trommelgavlene. Fest kroken slik at krokende ikke stikker ut i en seksjon uten slanger. På denne måte elimineres faren for hekting til kroken under inntromling av neste seksjon.



Klemfare

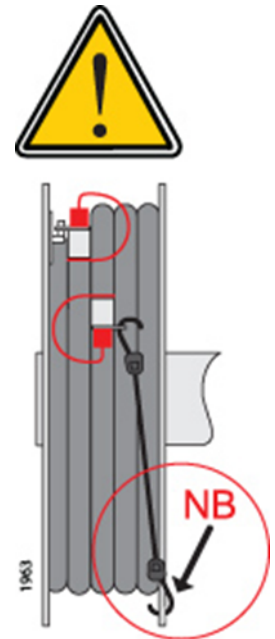

Avstenging

Når slangene er festet på trommelen slås sirkulasjonspumpe (104) av. Vendebryter slås av før nettkabelen frakobles. Følg stopprosedyren for aggregatet ved aggregatdrift. Lukk og lås dører og luker. HW maskinen er nå klar for transport.

BEMERK!

Slangeenden skal vende oppover når slangen festes til slangekroken.

Det er viktig at det holdes STREKK i slanger under inntromling SAMT at mest mulig jord og sand dras av slangen ved inntromling.



FARE

Fare for hekting av hender til trommelkrok og slange under inntromling

8. Overvåkning under drift

Denne seksjon tar for seg overvåking av HW maskinene under drift. Instruksjonene herunder forutsetter at systemet har oppnådd driftstemperatur.

BEMERK!

Det må alltid kontrolleres at slanger IKKE er i klem ELLER at det er KNEKK på slangen slik at sirkulasjon hindres.

8.1. Lokal overvåkning

Når HW maskinen er i drift kan man overvåke prosessen fra styrepanelet innenfor bakluken. HW 3600 har tre sirkulasjonskretser med separate strømningsindikatorer.

HW 1800 har felles strømningsindikator og felles temperaturmålere for tur- og returtemperatur.



HW 3600 Styrepanel

Tur temperaturen vil variere i sykluser med innkobling og utkobling av brenneren rundt den innstilte væsketemperaturen på kjelen.

Returtemperaturen vil alltid vise lavere temperatur enn tur temperatur. Normal returtemperatur er 50 – 100°C avhengig av antall slanger tilkoblet, tinetid, utetemperatur, grunnforhold og isolering. Returtemperaturen vil være lavest i starten da temperaturforskjellen mellom bakken og slangen er størst.

Systemtrykket på maskinen vil ligge i området 2-6 bar under normal drift. Systemtrykket vil variere avhengig av antall kretser, væsketemperatur og utleggsmønster. Operatørene av HW maskinene vil derfor gradvis opparbeide erfaring med de ulike parametrene.



Bruk av ANNET utstyr enn det maskinen er levert med kan gi uforutsette driftsproblemer og kan medføre PERSONSKADER.

8.2. Justering drift

I noen tilfeller vil de tre sirkulasjonskretsene ha ulik returtemperatur og strømningshastighet. Forutsatt at sløyfene har lik strømningshastighet, indikerer lav temperatur på en av sløyfene spesielt stor varmeavgivelse i kretsen. Kontroller at slangene er tilstrekkelig tildekket med isolasjonsmattene.

Ønskes det mindre tineeffekt på en sløyfe kan denne strupes med volumstrømregulatoren (ekstrautstyr). Mindre strømningshastighet vil avgi mindre varme. Strømningsvolum bedømmes visuelt av operatøren på strømningsindikatorerne.

Hvis et større område skal tines for graving, kan man ved å regulere strømningshastigheten regulere tinehastigheten på området etter rekkefølgen på gravearbeidet.

8.3. GSM Brukerveiledning

Bruk av GSM krever innsetting av SIM-kort. Kontantkort kan med fordel brukes. Ved programmering av SIM-kort må maskinen være tilkoblet nettstrøm eller strømaggregat må være i drift. NB! SIM kortets PIN-Kode må utkobles ved hjelp av en vanlig telefon før innsetting i maskinen.

8.4. Innsetting av SIM-kort

Prosedyre for å sette inn eller bytte SIM-kort:

1. Åpne EI-skap
2. Åpne gjennomsiktig plastdeksel på grønn boks
3. Sett inn nytt SIM-kort og trykk forsiktig kortet på plass.

Kontaktflaten til venstre og hakket på kortet ned/ut.

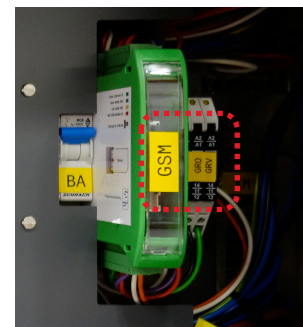

GSM-del i EI-skap

8.5. Indikatorlys

Når maskinen er i bruk blinker en lysdiode på GSM-enheten med ulike fargekoder:

- Rødt lys: Blinker når enheten ikke har kontakt med mobilnettet
- Grønt lys: Blinker ved kontakt med mobilnettet
- Orange lys: Blinker når SMS sendes fra enheten

8.6. Varslingsmeldinger

Maskinens GSM Kontrollstyring gir brukeren følgende varsel og forslag til tiltak:

VARSEL 1; DIESEL ALARM:

"Lavt dieselnivå på HW maskinen, 25 liter igjen på tanken."

VARSEL 2; BRENNER ALARM:

"Brenner har stoppet på HW maskinen. Reset rele på brenner. Dieselpumpe må luftes etter tørrkjøring"

VARSEL 3; NETTSPENNING:

"Nettspenningen har falt bort på HW maskinen. Kontroller inntakskabel og spenning Sjekk sikringer og aggregat."

VARSEL 4; GLYKOLNIVÅ:

"HW maskinen har stoppet pga for lavt VTV-væske nivå.

Sjekk evt. lekkasjer. Reparer og etterfyll væske.

VARSEL 5; BRENNER:

"Brenner har stoppet på HW maskinen. Reset overopphetingssikring på kontrollpanel på kjelen."

8.7. Servicemeldinger

Avlesing av tur-temperatur på VTV-Væske:

Send checktemp til GSM simkort

Stopp av brenner:

Send out2 on til GSM simkort

Start av brenner:

Send out2 off til GSM simkort

OBS!

Hvis brenneren stoppes med telefonen må den også startes opp med telefonen.

8.8. Legge til nye nummer

GSM varsling gir muligheten for varsling til 3 ulike nummer på hvert varsel. Ved innlegg av nye nummer slettes ikke gamle nummer da inntil 3 nummer kan varsles samtidig. Innlegg av nytt telefonnummer må gjøres til hvert varsel x eller bare på ønskede varsel. Følgende melding skrives til maskinen for å legge til nummer:

INxTEL_telefonnummer

Der x betegner meldingstype 1, 2 eller 3, og _ betegner mellomrom. Små og store bokstaver er valgfritt. Det må sendes en melding for hvert varsel.

Eksempel: For å legge samme nummer til alle varslingene sendes 5 meldinger:

IN1TEL 99955555

IN2TEL 99955555

IN3TEL 99955555

IN4TEL 99955555

IN5TEL 99955555

Hvis flere nummer ønskes varslet samtidig for et varsel brukes mellomrom mellom numrene. Maksimalt 3 nummer på hvert varsel.

Eksempel:

IN1TEL 99955555 80055555

8.9. Fjerne telefonnummer

For å fjerne alle telefonnummer på et varsel skrives:

INxTEL_OFF

Eksempel:

IN1TEL OFF

9. Indikatorer og feilmeldinger

9.1. Indikatorer på styrepanel

Pumpefeil

Hvis indikatoren for pumpefeil lyser, kan det være at brenner er startet og ikke pumpen eller at det er lite VTV-væske på tanken. Pumpen må alltid startes før brenner. Hvis dette ikke stemmer, bør man ta kontakt med servicepersonell for kontroll av den elektriske pumpemotoren.

Brennerfeil

Hvis indikatoren for pumpefeil lyser kan det være feil med drivstofftilførselen. Fyll evt. diesel hvis tom, luft dieseltilførselen, rengjør dieselfilter og kontroller brenner.

Indikatoren lyser også hvis brenneren har slått seg av pga fotomotstandsreleet (87). Dette skjer hvis brenneren slukkes pga nedslag i eksospipe. Reset/nullstill fotomotstandsrele på brenneren ved å trykke inn rød bryter.

Aggregat

Feil ved aggregatdrift. Her kan man lese feilkode ved driftsstans aggregat. Se vedlegg aggregat.

9.2. VTV nivåglass

Før VTV-nivået når minimum må det etterfylles med VTV-væske. Sirkulasjonspumpen vil stanse ved for lavt væsknivå.

Minimums nivå er indikert på nivåglasset for VTV tank. VTV væskemengde mellom minimum og maksimum er 35 liter.

Merk: Minimumsnivå er midt på VTV-tank!

9.3. Feilsøking HW maskinene

Feil	Mulige årsaker	Retting
"Pumpe feil"-indikator lyser.	<ul style="list-style-type: none"> ▪ Frekvensomformer i el-skap. ▪ Feil med pumpemotor/el-motor 	<ul style="list-style-type: none"> ▪ Kontroller feilkode på omformer og les manual ▪ Kontakt servicepersonell
Pumpe og brenner stopper/vil ikke starte. Varsellys er ikke tent.	<p>Lavt væsknivå i VTV-Tank</p>	<p>Fyll VTV-Væske</p>
Brenner starter ikke	<ul style="list-style-type: none"> ▪ Sirkulasjonspumpe ikke igangsatt først ▪ Overopphetingssikring slått ut 	<ul style="list-style-type: none"> ▪ Start pumpe først. ▪ Reset overopphetingssikring
"Brenner feil"-indikator lyser	<ul style="list-style-type: none"> ▪ Brenner slukket pga nedslag i eksopipe ▪ Feil med drivstofftilførselen ▪ Feil på brenner 	<ul style="list-style-type: none"> ▪ Reset/nullstill fotomotstands-rele på brenner (se manual) ▪ Fyll diesel, rengjør dieselfilter. Kontroller brenner ▪ Kontakt servicepersonell
Brenner stopper, Varsellys er ikke tent.	<p>Overopphetingssikring kan ha slått ut pga høy væsketemp og lav sirkulasjon</p>	<p>Reduser væsketemp, øk sirkulasjon og reset/nullstill sikring på kjele etter 3min</p>
Sort eksos fra kjele	<p>Feil innstilling av brennerparametre (luft, drivstoff, dyse og trykk) pga. høyde over havet eller slitasje</p>	<p>Kontakt servicepersonell</p>
Høyt turtrykk	<p>Flatklemt varmeslange</p>	<p>Slå av pumpen, kontroller slangene</p>

9.4. Feilsøking aggregat

Feil	Mulige årsaker	Retting
Startmotor fungerer, men motor tenner ikke	<ul style="list-style-type: none"> ▪ Fri for drivstoff ▪ Tett dieselfilter ▪ Utetemperatur lavere enn -18°C 	<ul style="list-style-type: none"> ▪ Fyll drivstoff og følg lufteprosedyre ▪ Rengjør dieselfilter ▪ Sørg for høyere starttemperatur
Lavt turtall	<ul style="list-style-type: none"> ▪ For stor strømbelastning ▪ Skittent luftfilter ▪ Tett dieselfilter 	<ul style="list-style-type: none"> ▪ Fjern eksterne forbrukere ▪ Rengjør luftfilter ▪ Rengjør dieselfilter
Sort eksos	<p>Skittent luftfilter</p>	<p>Rengjør luftfilter</p>
Startmotor går ikke/går sakte	<ul style="list-style-type: none"> ▪ Batteri er utladet ▪ Oljenivå under minimum ▪ Elektrisk feil eller feil med startmotor 	<ul style="list-style-type: none"> ▪ Lad batteri ▪ Fyll olje <p>Kontakt servicepersonell</p>

9.5. Feilsøking frekvensomformer

Drive does not start, no error code displayed

- If the display does not light up, check the power supply to the drive (ground and input phases connection, see page 19).
- The assignment of the "Fast stop" or "Freewheel" functions will prevent the drive starting if the corresponding logic inputs are not powered up. The ATV12 then displays **n5t** in freewheel stop and **F5t** in fast stop, it will display **rdy** in freewheel stop. This is normal since these functions are active at zero so that the drive will be stopped safely if there is a wire break. Assignment of LI to be checked in **COnF/FULL/FUn-/5t-t** - menu.
- Make sure that the run command input(s) is activated in accordance with the selected control mode (parameters **Type of control tCC** page 47 and **2 wire type control tCt** page 50, in **COnF/FULL/ I.O** - menu).
- If the reference channel or command channel is assigned to Modbus, when the power supply is connected, the drive displays "**n5t**" freewheel and remain in stop mode until the communication bus sends a command.
- In factory setting "RUN" button is inactive. Adjust parameters **Reference channel 1 Fr I** page 60 and **Command channel 1 Cd I** page 61 to control the drive locally (**COnF/FULL/CtL** - menu). See How to control the drive locally page 45.

Fault detection codes that cannot be reset automatically

The cause of the fault must be removed before resetting by turning off and then on.

50F and **t nF** faults can also be reset remotely by means of a logic input (parameter **Detected fault reset assignment r 5F** page 77 in **COnF/FULL/FLt** - menu).

InFb, **50F** and **t nF** faults can be inhibited and cleared remotely by means of a logic input (parameter **Detected fault inhibition assignment InH** page 81).

Code	Name	Possible causes	Remedy
C r F I	Precharge	<ul style="list-style-type: none"> • Charging relay control fault or charging resistor damaged 	<ul style="list-style-type: none"> • Turn the drive off and then back on again • Check the connections • Check the stability of the main supply • Contact your local Schneider Electric representative
InF I	Unknown drive rating	<ul style="list-style-type: none"> • The power card is different from the card stored 	<ul style="list-style-type: none"> • Contact your local Schneider Electric representative
InF 2	Unknown or incompatible power board	<ul style="list-style-type: none"> • The power card is incompatible with the control card 	<ul style="list-style-type: none"> • Contact your local Schneider Electric representative
InF 3	Internal serial link	<ul style="list-style-type: none"> • Communication fault between the internal cards 	<ul style="list-style-type: none"> • Contact your local Schneider Electric representative
InF 4	Invalid industrialization zone	<ul style="list-style-type: none"> • Inconsistent internal data 	<ul style="list-style-type: none"> • Contact your local Schneider Electric representative
InF 9	Current measurement circuit failure	<ul style="list-style-type: none"> • Current measurement is not correct due to hardware circuit 	<ul style="list-style-type: none"> • Contact your local Schneider Electric representative
- - - -	Problem of application Firmware	<ul style="list-style-type: none"> • Bad application firmware update using the Multi-Loader tool 	<ul style="list-style-type: none"> • Flash again the application firmware of the product
InF b	Internal thermal sensor failure	<ul style="list-style-type: none"> • The drive temperature sensor is not operating correctly • The drive is in short circuit or open 	<ul style="list-style-type: none"> • Contact your local Schneider Electric representative
InF E	Internal CPU	<ul style="list-style-type: none"> • Internal microprocessor fault 	<ul style="list-style-type: none"> • Turn the drive off and then back on again • Contact local Schneider Electric representative

Diagnostics and Troubleshooting

Fault detection codes that cannot be reset automatically (continued)

Code	Name	Possible causes	Remedy
OCF	Overcurrent	<ul style="list-style-type: none"> Parameters in the Motor control menu d r C - page 55 are not correct Inertia or load too high Mechanical locking 	<ul style="list-style-type: none"> Check the parameters Check the size of the motor/drive/load Check the state of the mechanism Connect line motor chokes Reduce the Switching frequency S F r page 57 Check the ground connection of drive, motor cable and motor insulation.
SCF1	Motor short circuit	<ul style="list-style-type: none"> Short-circuit or grounding at the drive output Ground fault during running status Commutation of motors during running status Significant current leakage to ground if several motors are connected in parallel 	<ul style="list-style-type: none"> Check the cables connecting the drive to the motor, and the motor insulation Connect motor chokes
SCF3	Ground short circuit		
SCF4	IGBT short circuit	<ul style="list-style-type: none"> Internal power component short circuit detected at power on 	<ul style="list-style-type: none"> Contact your local Schneider Electric representative
SOF	Overspeed	<ul style="list-style-type: none"> Instability Overspeed associated with the inertia of the application 	<ul style="list-style-type: none"> Check the motor Overspeed is 10% more than Maximum frequency t F r page 55 so adjust this parameter if necessary Add a braking resistor Check the size of the motor/drive/load Check parameters of the speed loop (gain and stability)
t n F	Auto-tuning	<ul style="list-style-type: none"> Motor not connected to the drive One motor phase loss Special motor Motor is rotating (being driven by the load, for example) 	<ul style="list-style-type: none"> Check that the motor/drive are compatible Check that the motor is present during auto-tuning If an output contactor is being used, close it during auto-tuning Check that the motor is completely stopped

Diagnostics and Troubleshooting

Fault detection codes that can be reset with the automatic restart function, after the cause has disappeared

These faults can also be reset by turning on and off or by means of a logic input (parameter [Detected fault reset assignment r 5 F](#) page 77). OHF, OLF, OPF1, OPF2, OSF, SLF1, SLF2, SLF3 and tJF faults can be inhibited and cleared remotely by means of a logic input (parameter [Detected fault inhibition assignment InH](#) page 81).

Code	Name	Possible causes	Remedy
LFF1	AI current lost fault	Detection if: <ul style="list-style-type: none"> Analog input AI1 is configured as current AI1 current scaling parameter of 0% CrLI page 51 is greater than 3 mA Analog input current is lower than 2 mA 	<ul style="list-style-type: none"> Check the terminal connection
ObF	Overbraking	<ul style="list-style-type: none"> Braking too sudden or driving load too high 	<ul style="list-style-type: none"> Increase the deceleration time Install a module unit with a braking resistor if necessary Check the line supply voltage, to be sure that it is under the maximum acceptable (20% over maximum line supply during run status)
OHF	Drive overheat	<ul style="list-style-type: none"> Drive temperature too high 	<ul style="list-style-type: none"> Check the motor load, the drive ventilation and the ambient temperature. Wait for the drive to cool down before restarting. See Mounting and temperature conditions page 12.
OLC	Process overload	<ul style="list-style-type: none"> Process overload 	<ul style="list-style-type: none"> Check the process and the parameters of the drive to be in phase
OLF	Motor overload	<ul style="list-style-type: none"> Triggered by excessive motor current 	<ul style="list-style-type: none"> Check the setting of the motor thermal protection, check the motor load.
OPF1	1 output phase loss	<ul style="list-style-type: none"> Loss of one phase at drive output 	<ul style="list-style-type: none"> Check the connections from the drive to the motor In case of using downstream contactor, check the right connection, cable and contactor
OPF2	3 output phase loss	<ul style="list-style-type: none"> Motor not connected Motor power too low, below 6% of the drive nominal current Output contactor open Instantaneous instability in the motor current 	<ul style="list-style-type: none"> Check the connections from the drive to the motor Test on a low power motor or without a motor: In factory settings mode, motor phase loss detection is active Output Phase loss detection OPPL page 80 = YES. To check the drive in a test or maintenance environment, without having to use a motor with the same rating as the drive, deactivate motor phase loss detection Output Phase loss detection OPPL = no Check and optimize the following parameters: IR compensation (law U/F) UFr page 56, Rated motor voltage Un5 page 55 and Rated motor current nCr page 55 and perform an Auto-tuning tUn page 58.
OSF	Main overvoltage	<ul style="list-style-type: none"> Line voltage too high: <ul style="list-style-type: none"> At drive power on only, the supply is 10% over the maximum acceptable voltage level Power with no run order, 20% over the maximum line supply Disturbed line supply 	<ul style="list-style-type: none"> Check the line voltage

Diagnostics and Troubleshooting

Fault detection codes that can be reset with the automatic restart function, after the cause has disappeared (continued)

Code	Name	Possible causes	Remedy
PHF	Input phase loss	<ul style="list-style-type: none"> • Drive incorrectly supplied or a fuse blown • Failure of one phase • 3-phase ATV12 used on a single-phase line supply • Unbalanced load • This protection only operates with the drive on load 	<ul style="list-style-type: none"> • Check the power connection and the fuses. • Use a 3-phase line supply. • Disable the fault by setting Input Phase loss detection IPL page 80 = n0.
SCFS	Load short circuit	<ul style="list-style-type: none"> • Short-circuit at drive output • Short circuit detection at the run order or DC injection order if parameter IGBT test S t r t page 81 is set to YES 	<ul style="list-style-type: none"> • Check the cables connecting the drive to the motor, and the motor's insulation
SLF1	Modbus communication	<ul style="list-style-type: none"> • Interruption in communication on the Modbus network 	<ul style="list-style-type: none"> • Check the connections of communication bus. • Check the time-out (Modbus time out t t D parameter page 83) • Refer to the Modbus user manual
SLF2	SoMove communication	<ul style="list-style-type: none"> • Fault communicating with SoMove 	<ul style="list-style-type: none"> • Check the SoMove connecting cable. • Check the time-out
SLF3	HMI communication	<ul style="list-style-type: none"> • Fault communicating with the external display terminal 	<ul style="list-style-type: none"> • Check the terminal connection
ULF	Process underload fault	<ul style="list-style-type: none"> • Process underload • Motor current below the Application Underload threshold L U L parameter page 53 during a period set by Application underload time delay U L t parameter page 53 to protect the application. 	<ul style="list-style-type: none"> • Check the process and the parameters of the drive to be in phase
t JF	IGBT overheat	<ul style="list-style-type: none"> • Drive overheated • IGBT internal temperature is too high according to ambient temperature and load 	<ul style="list-style-type: none"> • Check the size of the load/motor/drive. • Reduce the Switching frequency S F r page 57. • Wait for the drive to cool before restarting

Diagnostics and Troubleshooting

Faults codes that will be reset as soon as their causes disappear

The USF fault can be inhibited and cleared remotely by means of a logic input ([Detected fault inhibition assignment InH](#) parameter page [81](#)).

Code	Name	Possible causes	Remedy
FFF	Incorrect configuration	<ul style="list-style-type: none"> HMI block replaced by an HMI block configured on a drive with a different rating The current configuration of customer parameters is inconsistent 	<ul style="list-style-type: none"> Return to factory settings or retrieve the backup configuration, if it is valid. If the fault remains after reverting to the factory settings, contact your local Schneider Electric representative
CFI (1)	Invalid configuration	<ul style="list-style-type: none"> Invalid configuration The configuration loaded in the drive via the bus or communication network is inconsistent. The configuration upload has been interrupted or is not fully finished.	<ul style="list-style-type: none"> Check the configuration loaded previously. Load a compatible configuration
CFI2	Download invalid configuration	<ul style="list-style-type: none"> Interruption of download operation with Loader or SoMove 	<ul style="list-style-type: none"> Check connection with Loader or SoMove. To reset the default re-start the download operation or restore the factory setting
USF	Undervoltage	<ul style="list-style-type: none"> Line supply too low Transient voltage dip 	<ul style="list-style-type: none"> Check the voltage and the parameters of Undervoltage Phase Loss Menu U5b - page 81.

(1) When the CFI is present in the past fault menu, it means the configuration has been interrupted or is not fully finished.

HMI block changed

When an HMI block is replaced by an HMI block configured on a drive with a different rating, the drive locks in Incorrect configuration **FFF** fault mode on power-up. If the card has been deliberately changed, the fault can be cleared by pressing the ENT key twice, which **restores all the factory settings**.

Diagnostics and Troubleshooting

Remote keypad error messages

Code	Name	Description
InIt:	On initializing itself	<ul style="list-style-type: none"> Micro controller initializing Communication configuration search
CDN.E (1)	Communication error	<ul style="list-style-type: none"> It has 50ms time out error. This message is shown after 220 retry attempts.
R-IT (1)	Key alarm	<ul style="list-style-type: none"> Key has been pressed consecutively for more than 10 seconds. Membrane switch disconnected. Keypad woken up while a key is being pressed.
CLr (1)	Confirm Fault reset	<ul style="list-style-type: none"> This message appears if the STOP key is pressed when there is a keypad fault.
DEU.E (1)	Drive mismatch	<ul style="list-style-type: none"> Drive type (brand) did not match with keypad type (brand)
rDN.E (1)	ROM abnormality	<ul style="list-style-type: none"> Keypad ROM abnormality detected by the checksum calculation.
rRN.E (1)	RAM abnormality	<ul style="list-style-type: none"> Keypad RAM abnormality detected.
CPU.E (1)	The other defect	<ul style="list-style-type: none"> The other defect.

(1) Flashing

10. Sommerlagring

I sommersesongen vil HW maskinen normalt ha mindre eller ingen anvendelse og må derfor lagres på en tilfredsstillende måte, slik at den klargjort til neste sesong. Det er viktig at maskinen har optimale lagringsbetingelser.

HW maskinen bør rengjøres grundig før sommerlagring. Spesielt viktig er det at slanger er dratt ut og rengjort før de legges på trommel for lagring. Slangene dras ut av trommel og sjekkes grundig for defekter og skader. Dette gjøres for både slanger og koblinger.

Videre er generell rengjøring av hele maskinen å anbefale.

VTV systemet skal være oppfylt med VTV-væske både i tank og slanger. Eventuelle nye slanger skal også fylles opp med VTV væske. VTV væsken hindrer korrosjon i systemet.

Utfør service på kjele og brenner i henhold til vedlegg i denne manualen. Service skal utføres av sertifisert personell/firma.

Dieseltank fylles for lagring.

Dieselfilteret byttes ut med nytt.

VTV filter sjekkes, skadet filter byttes ut.

Eksos og andre åpninger på maskinen tildekkes slik at ikke fremmedelementer kan komme inn.

Eventuelle batteri frakobles og lagres tørt.

Maskinen skal ALLTID holdes låst.

Service etter bruk av maskinen en vintersesong er viktig for effektiv bruk av maskinen neste sesong. Det er også viktig mht garantien på nye maskiner.

Våre serviceteknikere skifter filter, dyse, rengjør brenner/kjele, måler og kan ved behov justerer avgasser fra brenneren. De sjekker slanger, koblinger, sikkerhetsventiler og funksjonskontroll av hele maskinen.



FARE

Det er spesielt viktig at slanger og koblinger er i god stand. Havari i VTV krets kan medføre alvorlig personskade ved driftstemperatur. Erstatt eller reparer komponenter som er skadet eller slitt slik at faren elimineres.

VIKTIG!

Tøm aldri sirkulasjonssystemet for VTV-Væske. Dette vil forringe korrosjonsbeskyttelsen. Uttyning eller bruk av andre VTV væsker kan skade sirkulasjonspumpen.

11. Garantier

11.1. Vilkår for garanti

HW maskinene leveres med garanti. Ved kjøp leveres garantivilkår med maskinen i form av "Salgsbetingelser for HeatWork".

Garantien gjelder for de første 1500 timer/1 år, avhengig av hva som inntreffer først.

Maskinens driftstid som det refereres til i SALGSVILKÅRENE er maskinens sirkulasjonstid som er angitt av timetelleren på instrumentpanelet.

For å oppnå garantidekning forutsettes at maskinen brukes i henhold til brukermanualen. Garanti dekning oppnås ikke ved bruk av uoriginale komponenter eller deler.

Ved bruk av andre brennstoffer eller annet enn original HW VTV-Væske vil ikke garantidekning gjelde.

Heatwork AS vil kunne kreve fremleggelse av dokumentasjon på at maskinen er vedlikeholdt i henhold til servicehefte for at garantien skal være gyldig. Videre skal det dokumenteres at autoriserte firma eller personell har utført service på kjele og brenner. Serviceheftet skal derfor følges og utfylles korrekt.

Bruk av tilhenger til annet enn det den er beregnet for vil ikke gi noen form for garantidekning.

BEMERK!

Detaljerte garantivilkår er beskrevet i SALGSBETINGELSER FOR HEATWORK AS

12. Sjekk og vedlikehold

Periodisk sjekk og vedlikehold er svært viktig for at maskinen skal operere feilfritt og vare lenge. Nedenfor er de ulike servicepunktene beskrevet. Vedlagt brukermanualen ligger et servicehefte for logging og beskrivelse av drift- og tidsintervall for service på maskinen. Manglende overholdelse av serviceintervall og dokumentasjon medfører bortfall av garanti.

Hvis både driftstid og tidsintervall er oppgitt, skal første inntrufne intervall benyttes.

12.1. Daglig sjekk

Kontroller Indikatorer på instrumentpanelet.

Sjekk drivstoffnivået og etterfyll om nødvendig. Tørrkjøring av systemet forårsaker driftsstans og behov for lufting av drivstoffsystemet.

Sjekk at nivå på VTV-væske er opp mot maks nivået.

Hvis væsknivået er på minimum er det sannsynlig at det har oppstått lekkasje på varmeslangene. Kontroller slangene og skjøt evt. midlertidig slangebrudd med deler i reservedelspakken. Pumpen vil automatisk stanse ved væsknivå under minimum. Fyll på ny væske etter den oppgitte prosedyren.

En del VTV-væske fordampes under drift av maskinen. Etterfyll derfor VTV-væske ved behov.



Under ALLE vedlikeholds-operasjoner SKAL systemet være HELT NEDKJØLT og STRØMTILFØRSEL FRAKOBLET



ALLE komponenter som har SKADER eller DEFEKTER må ALLTID byttes ut med nye originale deler

12.2. Skifte av filter på VTV-system

Det lukkede væskesystemet blir filtrert av ett sirkulasjonsfilter på sugesiden av pumpen. Dette beskytter pumpen for skadelige partikler. Det er særdeles viktig at intervallene for filterbytte følges for å sikre maskinens levetid.

- Prosedyre for å skifte VTV-filter: Steng begge kraner på hver side av filterhus.
- Plasser et oppsamlingskar under filter da det vil dreneres ut ca 1 liter væske etter demontering.
- Skift Filter.
- Sett kranene tilbake til opprinnelig posisjon.

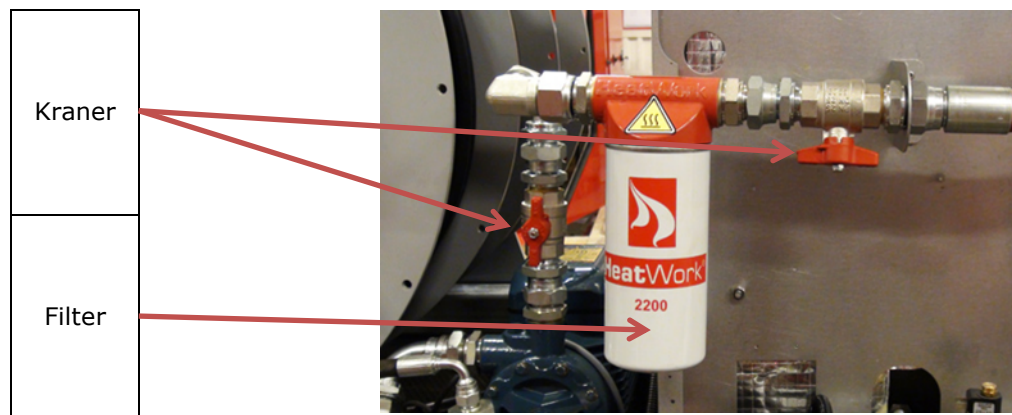

12.3. Skifte av dieselfilter brenner

Dieselfilteret står over inspeksjonslokket på dieseltanken. Filteret filtrerer drivstoff til brenner. Eget dieselfilter til aggregatet. (se egen driftshåndbok for aggregat)

Ved skifte av filter skrues filterglasset av, sjekk O-ring og monter nytt filterelement. Dieselsystemet må utluftes manuelt etter filterbytte:

1. Demonter plastdeksel på brenner
2. Åpne plugg eller skrue
3. Start opp maskinen; pumpe og brenner
4. Trykk inn og slipp reset fotomotstands releet
5. Gjenta punkt 3 inntil brenner tenner
6. Skru igjen plugg eller skrue i punkt 2
7. Monter plastdeksel til brenner jfr punkt 1

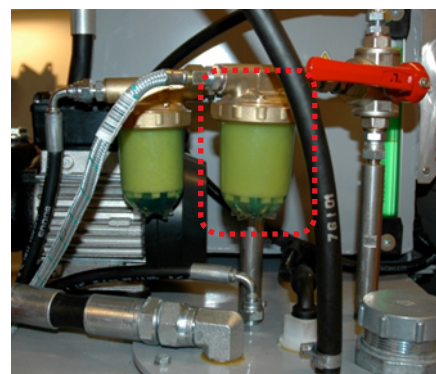

Dieselfilter brenner

12.4. Vedlikehold av aggregat

Dieselfilteret står over inspeksjonslokket på dieseltanken.

Filteret filtrerer drivstoff til aggregat. Filteret skal skiftes hver gang det skiftes olje på aggregatet.

Ved skifte av filter skrues filterglasset av, sjekk O-ring og monter nytt filterelement.

Væskekjølt aggregat: Oljeskift første gang etter 50 timer. Deretter hver 250. time.

Serviceintervall på 250 timer krever spesialolje.

For alt annet vedlikehold/service, se egen driftshåndbok for serviceveiledning. Benytt HeatWorks servicehefte for dokumentasjon av servicer. Manglende service og dokumentasjon i hht. servicehefte medfører bortfall av garanti.

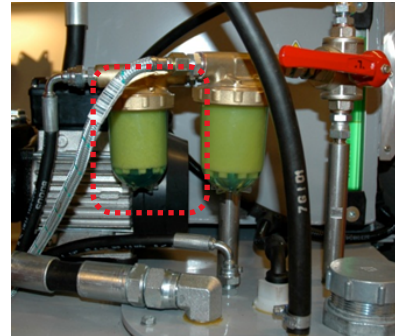

Dieselfilter aggregat

12.5. Lagring av maskin

Hvis maskinen ikke skal brukes over en lengre periode anbefales det at drivstofftanken fylles helt full.

12.6. Tømming av dieseltank

Bruk egnet pumpe for tømming av dieseltank.

12.7. Utskifting av VTV-Væske

VTV-væsken har 4 hovedfunksjoner:

1. Hindre frysing i system
2. Heve kokepunktet
3. Smøre pumpe
4. Hindre korrosjon

Da kvaliteten på VTV-væsken forringes ved bruk, må væsken kontrolleres jevnlig og skiftes ved behov for å unngå maskinhavari. Det skal kun benyttes original VTV-væske. Bruk av andre typer kjølevæsker eller blandingsforhold kan føre til driftsforstyrrelser/ problemer. Garantien gjelder ikke i slike tilfeller.

Når VTV-væsken skal byttes følges prosedyren på klistremerket i marginen. VTV-væsken leveres som spesialavfall på godkjent avfallsdeponi. Ved fylling av ny væske stenges dreneringskran nede på kjele og fylleprosedyre følges.

12.8. Brenner

Brenneren skal ha service hver 1500 driftstimer (timeteller på instrumentpanelet) eller hvert år.

Sort eksos indikerer feil med brenneren. Stopp maskinen og tilkall servicepersonell.

Det anbefales ved sesongslutt at brenner gjennomgår vedlikehold i henhold til brennerens brukermanual, se vedlegg. Vedlikehold av brenner må utføres av autorisert fagpersonell.

BEMERK!

BRENNER og KJELE vil miste effekt ved mangelfullt vedlikehold.

12.9. Kjele

Kjelen skal ha service samtidig som brenneren. Kjelen gjennomgår vedlikehold i henhold til kjelens brukermanual, se vedlegg.

Vedlikehold av kjele må utføres av autorisert fagpersonell.

12.10. Slinger

HW tineslanger bør rengjøres med en klut under inntromling av slange etter tineoperasjoner. Arbeidshansker er påkrevd når inntromling foregår. Det anbefales at HW-Slanger rengjøres utvendig jevnlig gjennom spyling med varmt vann.

HeatWork anbefaler sterkt slangeskift hvert tredje år av sikkerhetsmessige årsaker da tineslangene holder varm væske under trykk. Slitte slanger utgjør en risiko for alvorlig grad av forbrenning ved brudd.

Ved lekkasje eller brudd på slangen stanses sirkulasjonspumpen øyeblikkelig. Kapp slangen på begge sider av skade/bruddstedet og monter midlertidig reparasjonskobling som finnes i reservedelsposen. Reparasjonskobling ligger i aggregat-rom på hengeren. Så snart tinejobben er ferdig må det foretas en permanent slangeskjøting med presskoblingen som medfølger reparasjonspakken. Maskinen må ikke brukes før den skadede slangen er forskriftsmessig reparert eller byttet ut. Etterfyll VTV-væske i henhold til prosedyre.

Kontroller alltid slanger for skader under inntromling.



Skadde slanger må ALLTID byttes ut eller repareres umiddelbart.

13. Tekniske data

Tekniske spesifikasjoner	HW 3600
Vekt henger uten/med diesel	1860 kg / 2180 kg
Pumpekapasitet	3900 l/t
Antall pumper	1 stk
Systemtrykk normal drift	Ved oppstart: 2-6 bar. Under drift: 2-6 bar
Maks varmeeffekt	103 KW
Brennertype	1-trinns
Fyringsteknisk virkningsgrad	94% - dokumenter høyest i industrien
Væsketemperatur	Regulerbar 0-105°C (Flow temperatur)
Drivstoffbruk	Maks 9,0 liter/time ved konstant brennerdrift
Diesel	Vinterdiesel, arktisk klasse 2. Biodiesel BFO2G
Arbeidsintervall (veil m/full tank)	3,3 døgn (basert på gjennomsnittlig forbruk)
Kapasitet dieseltank	320 liter
VTV-væske	HeatWork VTV-væske
VTV-tank volum	ca 50 liter
Industriell HeatWork-slange	Armert varmeslange. Temperatur maks 110°C Trykk maks 30 bar.
Væskevolum varmeslanger	0,2 liter/meter
Lengde varmeslanger totalt	630 m
Lengde enkeltslanger pr krets	210 m
Antall slangekretser	3
Tinekapasitet	200 m ²
Tinekapasitet med ekstra trommel	400 m ²
Elektrisk tilkobling/energiforbruk	230V – 16A
Ekstern dieseltanktilkobling	Inkludert
Servicedører	4 dører for lettere servicetilgang
TILLEGGSUTSTYR for montering	
GSM-Kontrollovervåkning	Varsler via SMS ved uregelmessigheter
GPS posisjonering	GPS posisjonering og driftshistorie (abonnement)
Aggregat, støyisolert	Cummins 4,8 kW, væskekjølt, tosylindret motor
Autostart aggregat	Aggregat starter automatisk ved bortfall av nettstrøm
Ekstra strømuttak	16A uttak på strømaggregat
LED lysmast	LED lyskaster/praktisk og robust lyskaster. Festes på maskin

Tekniske spesifikasjoner	HW 1800
Vekt henger uten/med diesel	1680 kg / 2000 kg
Pumpekapasitet	2100 l/t
Antall pumper	1 stk
Systemtrykk normal drift	Ved oppstart: 2-6 bar. Under drift: 2-6 bar
Maks varmeeffekt	70 KW
Brennertype	1-trinns
Fyringsteknisk virkningsgrad	94% - dokumenter høyest i industrien
Væsketemperatur	Regulerbar 0-105°C (Flow temperatur)
Drivstoffbruk	Maks 9,0 liter/time ved konstant brennerdrift
Diesel	Vinterdiesel, arktisk klasse 2. Biodiesel BFO2G
Arbeidsintervall (veil m/full tank)	3,3 døgn (basert på gjennomsnittlig forbruk)
Kapasitet dieseltank	320 liter
VTV-væske	HeatWork VTV-væske
VTV-tank volum	ca 50 liter
Industriell HeatWork-slange	Armert varmeslange. Temperatur maks 110°C Trykk maks 30 bar.
Væskevolum HW-slange	0,2 liter/meter
Lengde varmeslanger totalt	630 m
Lengde enkeltslanger pr krets	315 m
Antall slangekretser	2
Tinekapasitet	200 m ²
Elektrisk tilkobling/energiforbruk	230V – 10A
Ekstern dieseltanktilkobling	Inkludert
Servicedører	4 dører for lettere servicetilgang
TILLEGGSTYR for montering	
GSM-Kontrollovervåkning	Varsler via SMS ved uregelmessigheter
GPS posisjonering	GPS posisjonering og driftshistorie (abonnement)
Aggregat, støyisolert	Cummins 4,8 kW, væskekjølt, tosylindret motor
Autostart aggregat	Aggregat starter automatisk ved bortfall av nettstrøm
Ekstra strømuttak	16A uttak på strømaggregat
LED lysmast	LED lyskaster. Festes på maskin

Tekniske spesifikasjoner	Henger 3600	HW 1800
Akseltrykk	1200 kg	1000 kg
Dragkroktrykk	100 kg	100 kg
Felgdimensjon	4,5 JX 12 H2	4,5 JX 12 H2
Dekkdimensjon	155/80 R13C 84N	155/80 R13C 84N
Vektklasse dekk	500 kg	500 kg
Lufttrykk dekk	44/300 Psi/kPa	44/300 Psi/kPa

14. MY35

14.1. Oversikt HW MY35

Dette kapitlet gjelder spesifikke funksjoner som gjelder kun MY35.

Kapittel 1 – 13 omfatter funksjonene som er felles på alle HeatWork maskiner.

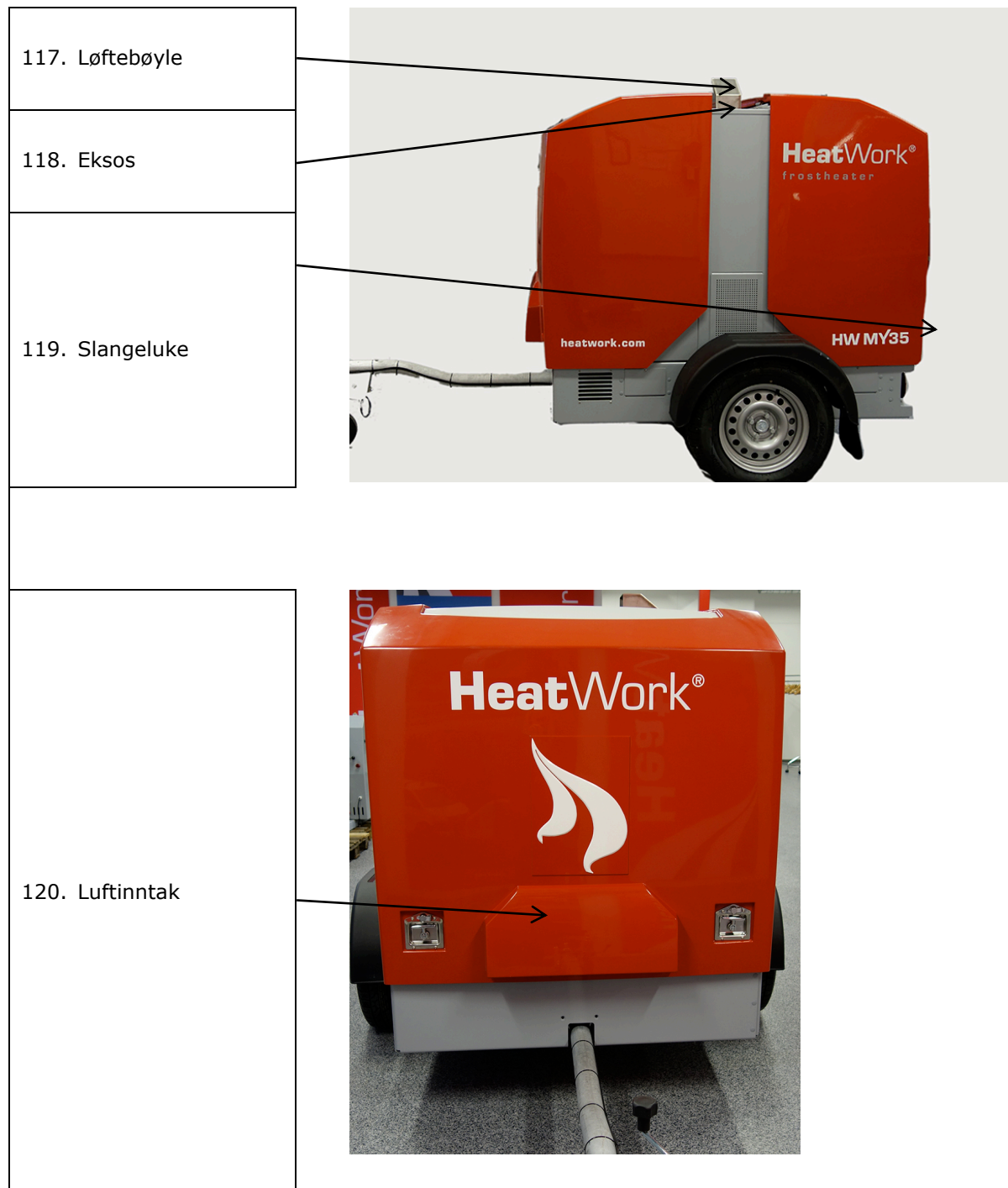

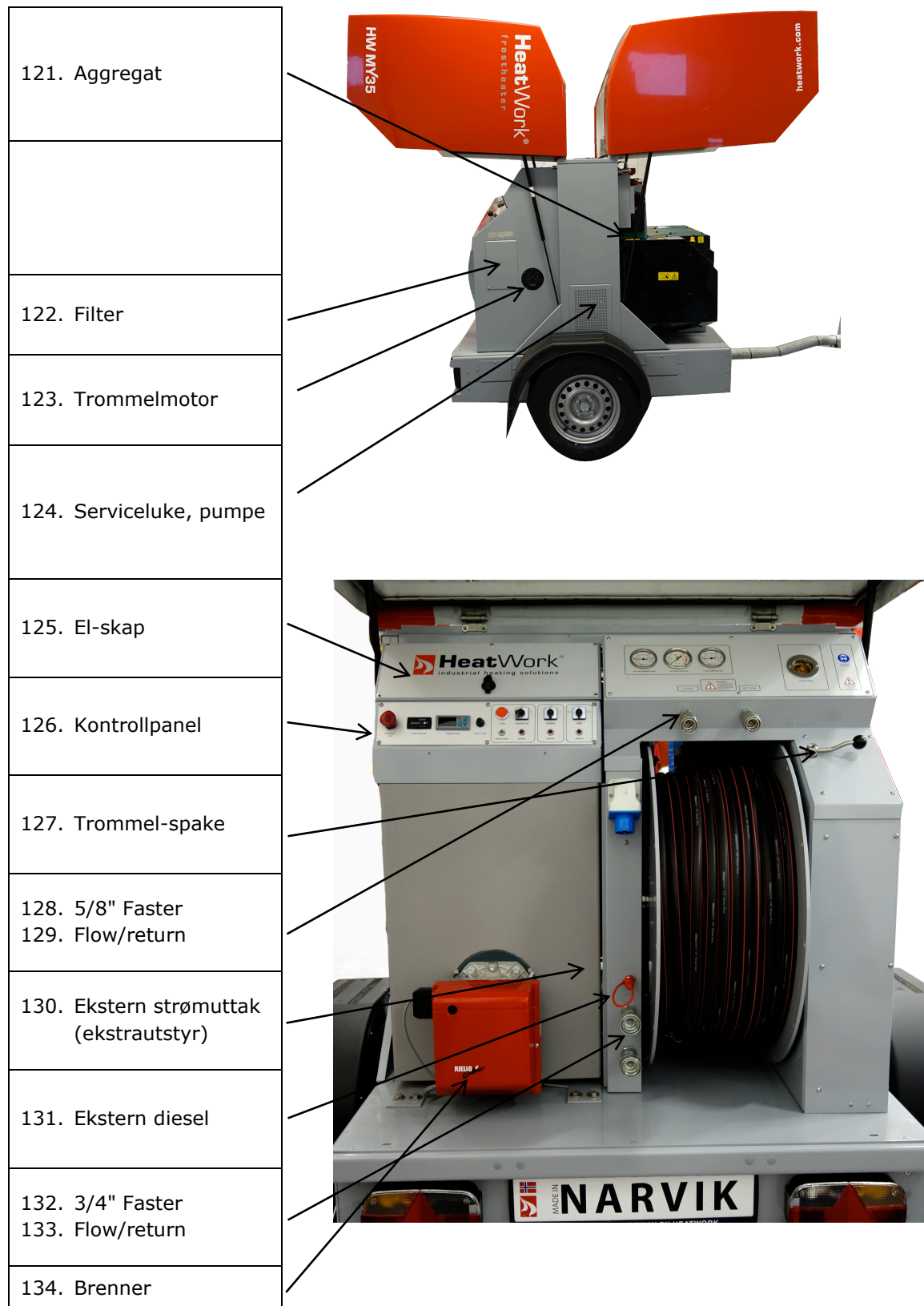

14.2. Oversikt styrepanel HW MY35

135. Returtemperatur	136. Systemtrykk	137. Tur temperatur
----------------------	------------------	---------------------

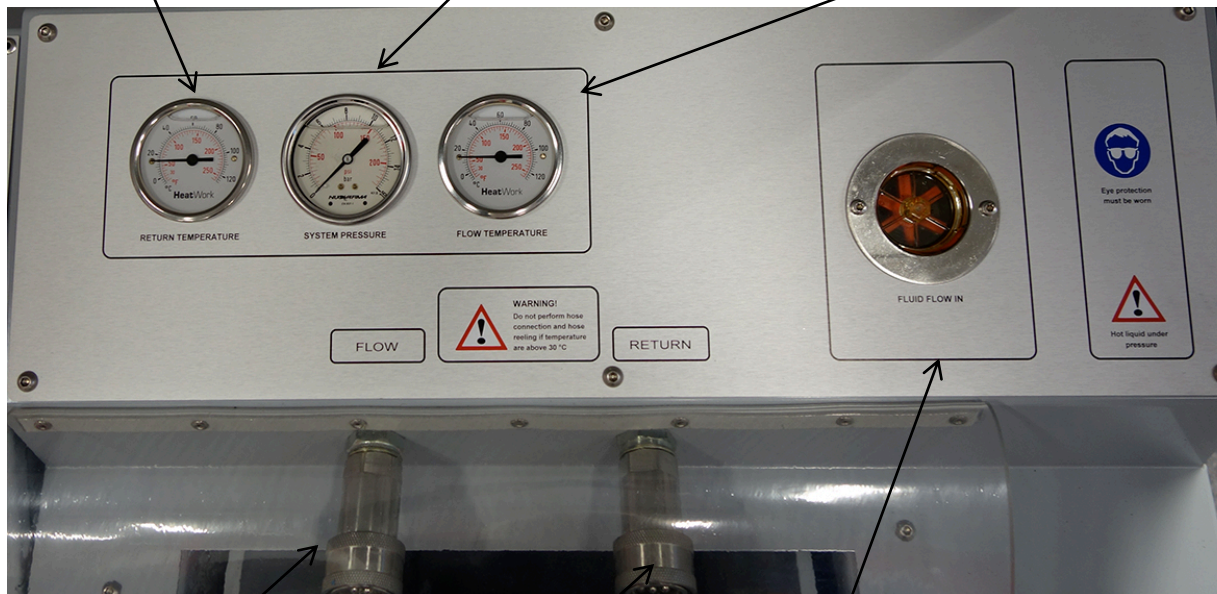

138. Turkobling	139. Returkobling	140. Sirkulasjonsindikator
-----------------	-------------------	----------------------------

141. Timeteller sirkulasjons-pumpe	142. Stopp aggregat	143. Start aggregat / autostart	144. Indikatorlys. Brennerfeil	145. Brenner bryter
------------------------------------	---------------------	---------------------------------	--------------------------------	---------------------



146. Nødstop	147. Driftslys aggregat	148. Indikatorlys Aggregatfeil	149. Indikatorlys Pumpefeil	150. Pumpe-bryter
--------------	-------------------------	--------------------------------	-----------------------------	-------------------

14.3. Elektroskap HW MY35

151. Sikring pumpe (16A)	152. Sikring forbrukere (6A)	153. Kontaktor brenner	154. Batteri (4A) DC	155. GSM sender
--------------------------	------------------------------	------------------------	----------------------	-----------------

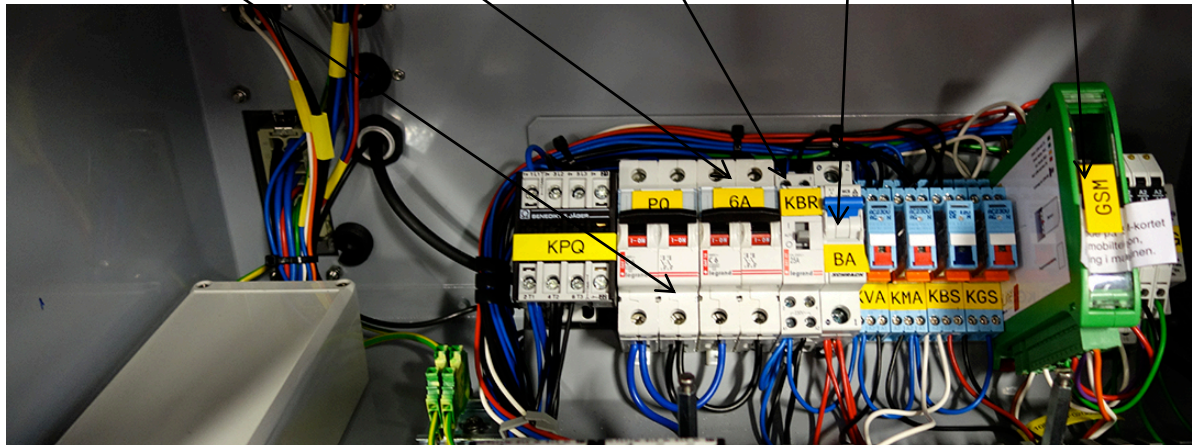

14.4. Bruksområder HW MY35

HW MY35 er en mobil enhet på 35 kW. Bruksområdene er tilsvarende øvrige FrostHeater (se for eksempel kapittel 3). Maskinen er meget mobil, lett i vekt og fleksibel i bruk og enkel å transportere.

14.5. Spesifikke sikkerhetsanmerkninger, HW MY35

Under drift vil primærsiden (VTV) nå en temperatur på opp mot 115°C. Sekundærsiden (vannsiden) vil nå en temperatur opp mot 99°C. Høye temperaturer på komponenter, slanger og væske kan medføre brannskade/skolding ved kontakt. Dette er spesielt viktig ved produksjon av forbruksvann og ved frakobling av tilførselsslanger. Anbefalt driftstemperatur ved frakobling er under 40°C.

Personlig verneutstyr

Under drift vil VTV-væsken kunne ha en væsketemperatur på opptil 115°C. Ved arbeid med en slik høy temperatur er det viktig at operatøren tar forholdsregler om bruk av personlig verneutstyr. Det anbefales at operatører alltid bruker arbeidstøy som er godkjent for varme arbeider, vanntette arbeidshansker, vernesko og arbeidshjelm under arbeidsoperasjoner med HW maskinene i tillegg til de påbudte vernebrillene.

Det oppfordres at operatøren har med i trekkvognen/arbeidsbilen, eller på et annet oppvarmet sted i maskinens nærhet, et sett førstehjelpsutstyr og øyeskyll. Dette må av naturlige årsaker oppbevares frostfritt og lett tilgjengelig. Se vedlegg for HMS datablad for HW VTV-væske.



Øyevern påbudt



Varm væske under trykk

14.6. Transport av HW MY35

Se standard transportprosedyre (Kapittel 6). I tillegg må HydroHeater dreneres og frostsikres etter bruk og før transport i kaldt klima.

14.7. Prosedyre

Se kapittel 7.1

14.8. Indikatorer og feilmeldinger

Feilsøking MY35

Feil	Mulige årsaker	Retting
"Pumpe feil"-indikator lyser.	<ul style="list-style-type: none"> ▪ Feil med pumpemotor/el-motor 	<ul style="list-style-type: none"> ▪ Kontakt servicepersonell
Pumpe og brenner stopper/vil ikke starte. Varsellys er ikke tent.	Lavt væsknivå i VTV-Tank	Fyll VTV-Væske
Brenner starter ikke	<ul style="list-style-type: none"> ▪ Sirkulasjonspumpe ikke igangsatt først ▪ Overopphetingssikring slått ut 	<ul style="list-style-type: none"> ▪ Start pumpe først. ▪ Reset overopphetingssikring
"Brenner feil"-indikator lyser	<ul style="list-style-type: none"> ▪ Brenner slukket pga nedslag i eksospipe ▪ Feil med drivstofftilførselen ▪ Feil på brenner 	<ul style="list-style-type: none"> ▪ Reset/nullstill fotomotstands-rele på brenner (se manual) ▪ Fyll diesel, rengjør dieselfilter. Kontroller brenner ▪ Kontakt servicepersonell
Brenner stopper, Varsellys er ikke tent.	Overopphetingssikring kan ha slått ut pga høy væsketemp og lav sirkulasjon	Reduser væsketemp, øk sirkulasjon og reset/nullstill sikring på kjele etter 3min
Sort eksos fra kjele	Feil innstilling av brennerparametre (luft, drivstoff, dyse og trykk) pga. høyde over havet eller slitasje	Kontakt servicepersonell
Høyt turtrykk	Flatklemt varmeslange	Slå av pumpen, kontroller slangene

Feilsøking aggregat

Feil	Mulige årsaker	Retting
Startmotor fungerer, men motor tenner ikke	<ul style="list-style-type: none"> ▪ Fri for drivstoff ▪ Tett dieselfilter ▪ Utetemperatur lavere enn -18°C 	<ul style="list-style-type: none"> ▪ Fyll drivstoff og følg lufteprosedyre ▪ Rengjør dieselfilter ▪ Sørg for høyere starttemperatur
Lavt turtall	<ul style="list-style-type: none"> ▪ For stor strømbelastning ▪ Skittent luftfilter ▪ Tett dieselfilter 	<ul style="list-style-type: none"> ▪ Fjern eksterne forbrukere ▪ Rengjør luftfilter ▪ Rengjør dieselfilter
Sort eksos	Skittent luftfilter	Rengjør luftfilter
Startmotor går ikke/går sakte	<ul style="list-style-type: none"> ▪ Batteri er utladet ▪ Oljenivå under minimum ▪ Elektrisk feil eller feil med startmotor 	<ul style="list-style-type: none"> ▪ Lad batteri ▪ Fyll olje Kontakt servicepersonell

14.9. Sjekk og vedlikehold

Skifte av filter på sekundærside

På vannsiden står filteret på tur siden av tanken og sugesiden av pumpen. Dette filtrerer vannet før det går inn på tanken og gjennom pumpen. Filter må sjekkes og byttes etter behov.

- Maskinen må kjøles ned til under 40°C.
- Sekundærpumpe må stoppes
- Åpne kran «Drain filter»
- Demonter dreneringsslange i bunn av filter
- Demonter filter ved at det skrues ut.
- Skift filter



Lagring av maskin

Ved lagring av maskin skal alle kraner være åpne, vanntanklokk bør være løst.

Sørg for at tilførselsslanger er tømt for vann.

Hvis sekundærkrets er forurenset bør systemet spyles før lagring.

14.10. Utskifting/etterfylling av VTV-Væske

VTV-væsken har 4 hovedfunksjoner:

1. Hindre frysing i system
2. Heve kokepunktet
3. Smøre Pumpe
4. Hindre korrosjon

Da kvaliteten på VTV-væsken forringes ved bruk, må væsken kontrolleres jevnlig og skiftes ved behov for å unngå maskinhavari. Det skal kun benyttes original VTV-væske. Bruk av andre typer kjølevæsker eller blandingsforhold kan føre til driftsforstyrrelser/ problemer. Garantien gjelder ikke i slike tilfeller.

Når VTV-væsken skal byttes følges prosedyre:

1. Koble VTV kanne til VTV tank med bunkringslange
2. Legg VTV kanne på toppen av maskinen
3. Overtrykksventil åpnes
4. Ta hull i VTV kannen

VTV-væsken leveres som spesialavfall på godkjent avfallsdeponi. Ved fylling av ny væske stenges dreneringskran nede på kjele og fyllprosedyre følges.

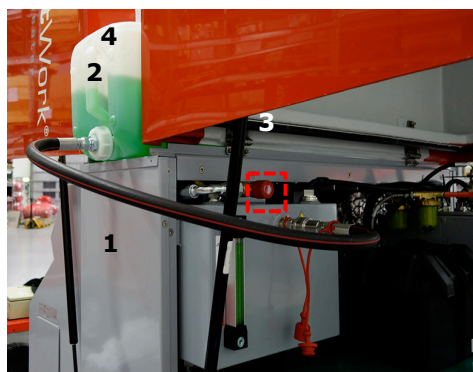

14.11. Tekniske data

Tekniske spesifikasjoner	MY35
Vekt henger	Fra 850 kg
Pumpekapasitet	2100 l/t
Antall pumper	1 stk x 2100
Systemtrykk normal drift	Ved oppstart: 2-6 bar. Under drift: 2-6 bar
Maks varmeeffekt	35 KW
Brennertype	1-trinns
Fyringsteknisk virkningsgrad	94% - dokumenter høyest i industrien
Væsketemperatur	Regulerbar 0-100°C (Flow temperatur)
Drivstoffbruk	Gjennomsnittlig forbruk 1,7 liter/time. Maks 3,0 liter/time ved konstant brennerdrift.
Diesel	Vinterdiesel, arktisk klasse 2. Biodiesel BFO2G
Arbeidsintervall (veil m/full tank)	Ca 58 timer (basert på gjennomsnittlig forbruk)
Kapasitet dieseltank	100 liter
VTV-væske	HeatWork VTV-væske
VTV-tank volum	ca 30 liter
Industriell HeatWork-slange	Armert varmeslange. Temperatur maks 110°C Trykk maks 30 bar.
Væskevolum HW-slange	0,2 liter/meter
Lengde varmeslanger totalt	210 m
Lengde enkeltslanger pr krets	210 m
Antall slangekretser	1
Tinekapasitet	70-140 m ²
Elektrisk tilkobling/energiforbruk	230V – 1100W
Ekstern dieseltanktilkobling	Inkludert
Servicedører	2 dører for lettere servicetilgang
TILLEGGSTYR for montering	
GSM-Kontrollovervåkning	Varsler via SMS ved uregelmessigheter
GPS posisjonering	GPS posisjonering og driftshistorie (abonnement)
Aggregat, støyisolert	Cummins 4,8 kW, væskekjølt, tosylindret motor
Autostart aggregat	Aggregat starter automatisk ved bortfall av nettstrøm
Ekstra strømuttak	16A uttak på strømaggregat
LED lysmast	LED lyskaster/praktisk og robust lyskaster. Festes på maskin

15. Vedlegg

15.1. HMS Datablad VTV-Væske

HMS Datablad VTV-Væske, Norsk

15.2. Brukerveiledning, Brenner: Riello DB4

Brukerveiledning, Brenner: Riello DB4, Engelsk

15.3. Brukerveiledning, Kjele: Atlas 95

Brukerveiledning, Kjele: Atlas 95, Engelsk

15.4. Brukerveiledning, Aggregat: Cummins Onan

Brukerveiledning, Aggregat: Cummins Onan, Engelsk

15.5. El Skjema

HW Autostart System

HW Boiler System

HW Fluid System

SIKKERHETS DATABLAD

I samsvar med 453/2010 og 1272/2008

(Alle henvisninger til EUs regelverk og direktiver er forkortet til bare nummerbetegnelse)

SEKSJON 1: IDENTIFIKASJON AV STOFFET / BLANDINGEN OG AV SELSKAPET / FORETAKET

1.1. Identifikasjon av stoffet eller stoffblandingen

Handelsnavn

VTV-væske

1.2. Relevant identifiserte bruksområder for stoffet eller blandingen og bruk det frarådes mot

Identifiserte bruksområder

Frostvæske

1.3. NASJONAL PRODUSENT/IMPORTØR

HeatWork AS, Postboks 353, 8505 NARVIK, Telefon +47 76 96 58 90

E-post: post@heatwork.com

1.4. Nærmere opplysninger om leverandøren av sikkerhetsdatabladet

PRODUSENT I EU/EØS, IMPORTØR TIL EU/EØS

Statoil Fuel & Retail Lubricants Sweden AB,

Box 194, 149 22 Nynäshamn, Sweden,

+46 8 429 60 00

1.5. Nødnummer

I nødsfall, kontakt giftinformasjon: 22 59 13 00; Medisinsk nødhjelp: tel 113; brann: 110; Politi: 112 Ikke akutt

giftinformasjon: <http://helsenorge.no/Helseogsunnhet/Giftinformasjon/Sider/default.aspx>

SEKSJON 2: FAREIDENTIFIKASJON

2.1. Klassifisering av stoff eller blanding Klassifisering etter 1272/2008

Dette produktet er ikke klassifisert som farlig, ved vurdering i henhold til 1272/2008.

Klassifisering etter 1999/45/EG

Produktet er vurdert og ikke klassifisert som farlig.

2.2. Etikettinformasjon

Etikettinformasjon enligt 1272/2008

Farepiktogrammer Ikke aktuelt

Signalord Ikke aktuelt

Faresetninger Ikke aktuelt

Etikettinformasjon enligt 1999/45/EG

Se Avsnitt 16.

2.3 Andre farer

Ikke aktuelt

SEKSJON 3: SAMMENSETNING / OPPLYSNING OM INNHOLDSTOFFER

Dette produktet består av en homogen vannløsning.

3.2. Blandinger

Merk at tabellen viser kjente farer for ingrediensene i ren form. Farene reduseres eller elimineres når de blandes eller spes ut, se avsnitt 16d.

Bestanddel	Klassifisering	Konsentrasjon
VANN		
CAS-Nr 7732-18-5	-	40 - 60%
EG-nummer 231-791-2	; -	
PROPYLENGLYKOL		
CAS-Nr 57-55-6	-	40 - 60%
EG-nummer 200-338-0	; -	
BITREX		
CAS-Nr 3734-33-6	Acute Tox 4oral, Skin Irrit 2, Eye Irrit 2, STOT SE 3resp; H302, H315, H319, H335	< 0,1%
EG-nummer 223-095-2	Xn; R22 R36/37/38	

Forklaringer til ingrediensene og merkingen er angitt i Avsnitt 16e. Offisielle forkortelser er skrevet med normal stil. Med kursiv stil angis spesifikasjoner og/eller kompletteringer som har blitt brukt ved beregning av blandingens klassifisering, se avsnitt 16b.

SEKSJON 4: FØRSTEHJELPSTILTAK

4.1. Beskrivelse av førstehjelpstiltak

Generelt: Ingen spesielle tiltak anses behøves. Om symptom allikevel forekommer, ta kontakt med lege.

Ved innånding: La den skadede hvile på varm plass med frisk luft. Gjenstår symptomet, oppsøk lege.

Ved øyekontakt: Om mulig, ta øyeblikkelig ut eventuelle kontaktlinser. Skyll øyeblikkelig med temperert vann 15 -20 min. med helt åpne øyne. Om symptom gjenstår, søk lege.

Ved hudkontakt: Normal vask av huden anses som nok. Om symptom allikevel forekommer, kontakt lege. Ta av forurensete klær.

Ved svelging: Skyll først munnen nøyte med mye vann men SVELG IKKE; Drikk minst en halv liter vann og kontakt lege. IKKE breknings.

4.2. Viktigste symptomer og effekter, både akutt og forsinket

Informasjon om symptomer er ikke entydige eller mangler for dette produktet.

4.3. Informasjon om umiddelbar legehjelp og spesiell behandling som eventuelt er nødvendig

Ikke aktuelt.

SEKSJON 5: TILTAK VED BRANNSLUKNING

5.1. Slokkingsmidler

Egnet brannslukningsmiddel

Slokkes med pulver eller kuldioksid. Brannmann kan bruke spredt vannstråle.

Slokkingsmidler som av sikkerhetsmessige grunner ikke skal brukes

Skal ikke slukkes med vann med høyt trykk.

5.2. Særlige eksponeringsfarer som skyldes selve stoffet eller stoffblandingen

Brenner under utvikling av røyk som inneholder skadelige gasser (kulloksid og kuldioksid), og ved ufullstendig forbrenning, aldehyder og andre giftige, skadelige, irriterende eller farlige stoffer.

Ikke brannfarlig.

Produktet er ikke oksiderende.

5.3. Særlig verneutstyr for brannslukningsmannskaper

Ved brann, bruk uavhengig pusteapparat.

SEKSJON 6: TILTAK VED UTILSIKTET UTSLIPP

6.1. Personlige forholdsregler, verneutstyr og nødprosedyrer

- Bruk passende allergitestede beskyttelseshansker.
- Gassmaske med filter A (brun) kan behøves.
- Ikke innånde produktet og unngå kontakt med hud og øyne.

6.2 Miljømessige forholdsregler

- La ikke produktet rinne ned i kloakksystemet. Om så allikevel skjer, ta umiddelbart kontakt med renholdsverket.
- Unngå utslipp til mark, vann eller luft.
- Ved veldig store utslipp 1 - 50 ton i elv eller innsjø, ta kontakt med redningsvesenet telefon 22 591300.

6.3. Metoder for opprydding og rengjøring

- Suge opp væsken i inert materiale f. eks. Vermikulit, samle siden stoffet til disposisjon.
- Forurenset produktet skal sendes som kjemisk avfall, og bli erklært som ikke-farlig gods.

6.4. Referanse til andre seksjoner

- Ikke aktuelt

SEKSJON 7: HÅNTERING OG LAGRING

7.1. Forholdsregler for sikker håndtering

- Håndter substansen som potensielt helsefarlig.
- Produktet skal oppbevares utilgjengelig for små barn og godt atskilt fra næringsmidler, nytelsesmidler og dyrefor.
- Spis, drikk og røyk ikke i rommet der dette produktet håndteres.

7.2. Særlig utforming av lagringsrom eller -beholdere inklusiv uforlidelige materialer

- Lagres ikke over normal romtemperatur.
- Håndteres i rom med modern ventilasjonsstandard.
- Oppbevares i godt ventilert skap, ikke over øynehøyde.
- Oppbevares kun i originalforpakning.

7.3 Særlig(e) bruksområde(r)

- Ikke aktuelt.

SEKSJON 8: EKSPONERINGSKONTROLL / PERSONLIG VERNEUTSTYR

8.1. Kontrollparametere

- 8.1.1 Nasjonale grenseverdier,

PROPYLENGLYKOL

- Nivågrenseverdi 25 ppm / 79 mg/m³
- Andre ingredienser (se avsnitt 3) savner hygieniske grenseverdier.

8.2 Begrensning av eksponering på arbeidsplassen

- For forebygging av risikoer i arbeidet er det ikke nødvendig å ta noen spesielle hensyn til dette produktet utover de generelle kravene som følger av EU-direktiv 89/391 og nasjonal arbeidsmiljølovgivning.
- Øyebeskyttelse bør anvendes ved risiko for direkte kontakt eller sprut. Vernehansker er normalt ikke nødvendig på grunn av egenskapene til dette produktet. Vernehansker kan være nødvendige på grunnlag av andre arbeidsforhold, f.eks. mekanisk risiko, temperaturforhold eller mikrobiologiske farer. Spesielt følsomme personer kan bruke hansker som er merket med "Low Chemical resistant" eller "Waterproof" eller med angitt piktogram.
- Ånderettsvern er kun nødvendig i ekstreme jobbsituasjoner. Rådfør med framstilleren.
- For begrensning av miljøeksponering, se Avsnitt 12.



SEKSJON 9: FYSISKE OG KJEMISKE EGENSKAPER

9.1. Informasjon om grunnleggende fysiske og kjemiske egenskaper

a) Utseende	Form: væske
	Farge: blank
b) Lukt	Ikke aktuelt
c) Luktterskel	Ikke aktuelt
d) pH	Ikke aktuelt
e) Smeltepunkt	Ikke aktuelt
f) Koepunkt/koekområde	Ikke aktuelt
g) Flammepunkt	Ikke aktuelt
h) Fordampingshastighet	Ikke aktuelt
i) Antennelighet (fast, gass)	Ikke aktuelt
j) Øvre/nedre antennelse- eller eksplosjonsgrense	Ikke aktuelt
k) Damptrykk	Ikke aktuelt
l) Dampdensitet	Ikke aktuelt
m) Relativ tetthet	Ikke aktuelt
n) Løselighet	Vannløselighet Ubegrenset løselig (100%)
o) Fordelingskoeffisient: n-oktanol/vann	Ikke aktuelt
p) Selvantenningsstemperatur	Ikke aktuelt
q) Nedbrytningstemperatur	Ikke aktuelt
r) Viskositet	Ikke aktuelt
s) Eksplosjonsegenskaper	Ikke aktuelt
t) Oksidasjonsegenskaper	Ikke aktuelt

9.2 Annen informasjon

Ingen informasjon tilgjengelig

SEKSJON 10: STABILITET OG REAKTIVITET

10.1. Reaktivitet: Produktet inneholder ingen stoffer som kan forårsake farlige reaksjoner under normale håndterings- og bruksforhold.

10.2. Kjemisk stabilitet: Produktet er stabilt under normale lagrings- og bruksforhold.

10.3. Risiko for farlige reaksjoner: Ingen kjente farlige reaksjoner.

10.4. Forhold som skal unngås: Ikke angitt

10.5. Materialer som skal unngås: Ikke angitt

10.6. Farlige spaltningsprodukter: Ingen ved normale forhold.

SEKSJON 11: TOKSIKOLOGISK INFORMASJON

11.1. Toksikologisk informasjon: Generell eller uspesifikk toksisitet. Produktet er ikke klassert som giftig.

Akutte virkninger: Ikke klassert som akutt giftig stoff.

Helseskadelighet: Produktet er ikke klassert som helseskadelig.

Giftighet ved gjentatt dose: Såvidt vi vet har ingen kroniske effekter blitt rapportert for dette stoff.

Kreftframkallende virkning: Såvidt vi vet har ingen kreftframkallende effekter blitt rapportert for dette stoff.

CMR-virkninger: Til kunnskapen vår, har ingen mutagene, andre genetiske eller reproduksjonstoksiske effekter rapporterte for dette produktet.

Sensibilisering: Overømfintlighetsreaksjoner kan ikke utelukkes hos ømfintlige personer.

Etsende og irriterende effekter: Produktet er ikke etsende. Mild irritasjon kan ikke utelukkes hos følsomme individer.

Synergisme og antagonisme: Så vidt vi vet er ingen synergieffekter rapportert med dette produktet eller noen av innholdstoffene.

Innvirkning på omdømme og andre psykologiske effekter: Såvidt vi vet påvirker dette produkt ikke omdømmet ved den tiltenkte bruken.

Virkninger på menneskelig mikroflora: Innvirkning på den menneskelige mikroflora kan ikke påvises eller er ubetydelig.

Relevant toksikologiske egenskaper

PROPYLENGLYKOL: LD50 Oral rotte ca 20000 mg/kg. LD50 Dermal kanin = 20800 mg/kg

SEKSJON 12: MILJØOPPLYSNINGER

12.1. Toksisitet

Dette produktet er laget av lett nedbrytbare naturlige eller naturidentiske ingredienser i hovedsak fra fornybare kilder, med den globale miljøbelastningen kan betraktes som ubetydelig. I lokalmiljøet kan økologiske konsekvenser oppstå ved store utslipp.

12.2. Persistens og nedbrytbarhet

Produktet er nedbrytbart i naturen.

12.3. Bioakkumulasjonspotensial

Dette produktet eller dets ingredienser akkumuleres ikke i naturen.

12.4. Mobilitet i jord

Indikasjon på bevegelse i naturen er fraværende, men det er ingen grunn til å tro at produktet er miljøskadelige, på grunn av dette.

12.5. Resultater av PBT og vPvB vurdering

Ikke angitt

12.6. Andre skadevirkninger

Ikke angitt

SEKSJON 13: FJERNING AV AVFALL

13.1. Egnede metoder for disponering av avfall

Avfallshåndtering for produktet

Produktet er ikke klassifisert som farlig avfall. Ta også hensyn til lokale regler for avfallshåndtering. Se også Avfallsforskriften (FOR-2004-06-01-930). Gjenvinning av produktet. Dette produkt gjenvinnes normalt ikke.

Transport av avfallet

Klasse J (0) - Ikke miljø- eller helseskadelig.

SEKSJON 14: TRANSPORTINFORMASJON

Dette produktet forventes kun å transporteres på vei eller med tog og er derfor kun vurdert ifølge regelverkene ADR/RID. Skulle annen transportmetode bli aktuell, ta kontakt med utgiveren av dette sikkerhetsdatabladet.

14.1. FN-nummer: Ikke farlig gods

14.2. Forsendelsesnavn: Ikke aktuelt

14.3. Klasse: Ikke aktuelt

14.4. Emballasjegruppe: Ikke aktuelt

14.5. Miljøfarer: Ikke aktuelt

14.6. Spesielle forholdsregler for bruker: Ikke aktuelt

14.7. Transport i bulk i henhold til vedlegg II til MARPOL 73/78 og IBC-koden: Ikke aktuelt

SEKSJON 15: OPPLYSNINGER OM LOVER OG FORSKRIFTER

15.1. Forskrift/regelverk om stoff eller blanding i forhold til sikkerhet, helse og miljø

Ikke aktuelt.

15.2. Kjemisk sikkerhetsvurdering

Rapport om kjemikaliesikkerhet ifølge 1907/2006 Vedlegg I er ikke nødvendig for dette produktet.

SEKSJON 16: ANDRE OPPLYSNINGER

16b. Forklaring av forkortelser i sikkerhetsdatabladet

Fulltekst for koder for fareklasse og kategori er nevnt i avsnitt 3

No phys haz	Ikke-tilordnet fysisk fare
Combust Liq	Brennbar væske med flammepunkt > 93 °C
No tox haz	Ikke klassifisert som giftig
No environmental hazard	Ikke klassifisert som miljøfarlig
Acute Tox 4oral	Akutt giftighet (Kategori 4 svelging)

Skin Irrit 2	Etsende/irriterende for huden (Kategori 2)
Eye Irrit 2	Øyeirritasjon (Kategori 2)
STOT SE 3resp	Spesifikk målorgantoksitet - enkelt eksponering; Kan forårsake irritasjon av luftveiene (Kategori 3)

Forklaringer til forkortelser i avsnitt 14

ADR Europeisk avtale vedrørende internasjonal transport av farlig gods på vei
RID Reglementet for internasjonal transport av farlig gods med tog

16c. Kildene til de viktigste data brukt ved utarbeidningen av sikkerhetsdatabladet

Datakilder

Primærdata for beregning av farene har først og fremst blitt hentet fra den offisielle europeiske klassifikasjonslisten, 1272/2008. Vedlegg I, oppdatert til 2013-02-06.

Der slike oppgaver mangler, ble det i andre hånd brukt den dokumentasjonen som ligger til grunn for den offisielle klassifiseringen, f.eks. IUCLID (International Uniform Chemical Information Database). I tredje hånd ble informasjonen fra ansette internasjonale kjemikalieforetak brukt, og i fjerde fra annen tilgjengelig informasjon, f.eks. fra andre leverandørers sikkerhetsdatablader eller fra ideelle organisasjoner, der en ekspertbedømmelse har blitt foretatt av kildens troverdighet. Hvis pålitelig informasjon ikke finnes til tross for dette, har farene blitt bedømt av ekspertise på grunnlag av kjente farer fra lignende stoffer, der prinsippene i 1907/2006 og 1272/2008 har blitt fulgt.

Fulltekst for forskrifter som er nevnt i dette sikkerhetsdatabladet

453/2010	Kommisjonsforordning (EU) nr. 453/2010 av 20. mai 2010 om endring av Europaparlaments og rådsforordning (EF) nr. 1907/2009 om registrering, vurdering, godkjenning og begrensninger av kjemikalier (REACH)
1272/2008	EUROPAPARLAMENTS- OG RÅDSFORORDNING (EF) nr. 1272/2008 av 16. desember 2008 om klassifisering, merking og emballering av stoffer og blandinger, om endring og oppheving av direktiv 67/548/EØF og 1999/45/EF, og om endring av forordning (EF) nr. 1907/2006
1999/45/EG	Europaparlaments- og rådsdirektiv 1999/45/EF av 31. mai 1999 om tilnærming av medlemsstatenes lover og forskrifter om klassifisering, emballering og merking av farlige stoffblandinger
89/391	Europaparlaments- og rådsdirektiv 89/391/EF
1907/2006	EUROPAPARLAMENTS- OG RÅDSFORORDNING (EF) nr. 1907/2006 av 18. desember 2006 om registrering, vurdering og godkjenning av samt begrensninger for kjemikalier (REACH), om opprettelse av et europeisk kjemikaliebyrå, om endring av direktiv 1999/45/EF og om oppheving av rådsforordning (EØF) nr. 793/93 og kommisjonsforordning (EF) nr. 1488/94 samt rådsdirektiv 76/769/EØF og kommisjonsdirektiv 91/155/EØF, 93/67/EØF, 93/105/EF og 2000/21/EF Vedlegg I

16d. Metoder for å evaluere opplysningene i henhold til 1272/2008 Artikkel 9 brukt i klassifiseringen

Beregningen av farene med denne blandingen er gjort som en samveid bedømmelse med hjelp av en ekspertbedømmelse i samsvar med 1272/2008 Vedlegg I, der all tilgjengelig informasjon som kan ha betydning for å fastsette farene med blandingen veies sammen, og i samsvar med 1907/2006 Vedlegg XI.

16e. Lister over relevante R-setninger, faresetninger og sikkerhetssetninger

Fulltekst for risikosetninger under avsnitt 3

R22	Farlig ved svelging
R36/37/38	Irriterer øynene, luftveiene og huden Fulltekst for faresetninger henhold til GHS/CLP under Avsnitt 3
H302	Farlig ved svelging
H315	Irriterer huden
H319	Gir alvorlig øyeirritasjon
H335	Kan forårsake irritasjon av luftveiene

16f. Råd om passende opplæring for ansatte for å beskytte menneskers helse og miljøet

Advarsel for feil bruk. Dette produkt er ikke forventet å forårsake alvorlig skade på mennesker eller miljø, men framstilleren, distributøren eller leverandør kan ikke ta ansvar for uvanlig eller ulovlig bruk av produktet.

Annen relevant informasjon

Etikettinformasjon enligt 1999/45/EG

Faresymbol	Ikke aktuelt
R-setninger	Ikke aktuelt
S-setninger	Ikke aktuelt

Kerosene burners

One stage operation



RDB



CODE	MODEL	TYPE
3748950	RDB3 CF	489T50
3748850	RDB4 CF	488T50

1	Declaration	3
2	Information and general warnings	4
2.1	Information about the instruction manual	4
2.1.1	Introduction	4
2.1.2	General dangers	4
2.1.3	Danger: live components	4
2.2	Guarantee and responsibility	5
2.3	Guidance for the use of bio fuel blends up to 10% where gas oil use is permitted by the appliance Manufacturer	5
2.3.1	Information and general instructions	6
2.3.2	Product Disclaimer Statement	6
3	Safety and prevention	7
3.1	Introduction	7
3.2	Safety warnings	7
3.3	Basic safety rules	7
3.4	Personnel training	7
4	Technical description of the burner	8
4.1	Technical data	8
4.2	Burner description	8
4.3	Burner equipment	8
4.4	Burner dimensions	9
4.5	Firing rates	9
5	Installation	10
5.1	Notes on safety for the installation	10
5.2	Handling	10
5.3	Preliminary checks	10
5.4	Installer/Service notes for the use of Gas oil with Bio blends up to 10% where gas oil use is permitted by the appliance Manufacturer	11
5.5	Working position	11
5.6	Boiler fixing	12
5.7	Burner assembly	13
6	Hydraulic systems	14
6.1	Fuel supply	14
6.1.1	Pump	14
6.2	One pipe system	15
6.2.1	Priming pump	15
6.3	Two pipe system	16
6.3.1	Priming pump	16
7	Electrical system	17
7.1	Notes on safety for the electrical wiring	17
7.2	Electrical wiring	18
7.2.1	Control box	18
8	Start-up, calibration and operation of the burner	19
8.1	Notes on safety for the first start-up	19
8.2	Combustion adjustment	19
8.3	Nozzles installation	20
8.3.1	Nozzles recommended	20
8.4	Pump pressure	20
8.5	Maintenance position	21
8.6	Air damper adjustment	21
8.7	Electrodes setting	21
8.8	Combustion head setting	22
8.9	Burner start-up cycle	22

9	Maintenance	23
9.1	Notes on safety for the maintenance.....	23
9.2	Maintenance programme	23
9.2.1	Maintenance frequency	23
9.2.2	Checking and cleaning	23
10	Faults / Solutions	24

1 Declaration

Declaration of conformity in accordance with ISO / IEC 17050-1		
Manufacturer:	RIELLO S.p.A.	
Address:	Via Pilade Riello, 7 37045 Legnago (VR)	
Product:	Kerosene burners	
Model:	RDB3 CF RDB4 CF	
These products are in compliance with the following Technical Standard:		
EN 292		
EN 267		
and according to the European Directives:		
MD	2006/42/EC	Machine Directive
LVD	73/23/EEC - 2006/95/EC	Low Voltage Directive
EMC	89/336/EEC - 2004/108/EC	Electromagnetic Compatibility

The quality is guaranteed by a quality and management system certified in accordance with UNI EN ISO 9001.

Legnago, 30.07.2010

Mr. G. Conticini
Burners Division Department
RIELLO S.p.A.



2 Information and general warnings

2.1 Information about the instruction manual

2.1.1 Introduction

The instruction manual supplied with the burner:

- is an integral and essential part of the product and must not be separated from it; it must therefore be kept carefully for any necessary consultation and must accompany the burner even if it is transferred to another owner or user, or to another system. If the manual is lost or damaged, another copy must be requested from the Technical Assistance Service of the area;
- is designed for use by qualified personnel;
- offers important indications and instructions relating to the installation safety, start-up, use and maintenance of the burner.

Symbols used in the manual

In some parts of the manual you will see triangular DANGER signs. Pay great attention to these, as they indicate a situation of potential danger.

2.1.2 General dangers

The **dangers** can be of **3 levels**, as indicated below.



Maximum danger level!
This symbol indicates operations which, if not carried out correctly, cause serious injury, death or long-term health risks.



This symbol indicates operations which, if not carried out correctly, may cause serious injury, death or long-term health risks.



This symbol indicates operations which, if not carried out correctly, may cause damage to the machine and/or injury to people.

2.1.3 Danger: live components



This symbol indicates operations which, if not carried out correctly, lead to electric shocks with lethal consequences.

Other symbols



ENVIRONMENTAL PROTECTION

This symbol gives indications for the use of the machine with respect for the environment.

- This symbol indicates a list.

Abbreviations used

Ch.	Chapter
Fig.	Figure
Page	Page
Sec.	Section
Tab.	Table

Delivery of the system and the instruction manual

When the system is delivered, it is important that:

- the instruction manual is delivered to the user by the system manufacturer, with the recommendation to keep it in the room where the heat generator is to be installed.
- The instruction manual shows:
 - the serial number of the burner;

.....

- the address and telephone number of the nearest Assistance Centre.

.....

- The system supplier must carefully inform the user about:
 - the use of the system;
 - any further tests that may be required before activating the system;
 - maintenance, and the need to have the system checked at least once a year by a representative of the manufacturer or another specialised technician.
To ensure a periodic check, the manufacturer recommends the drawing up of a Maintenance Contract.

2.2 Guarantee and responsibility

The manufacturer guarantees its new products from the installation date, in accordance with the regulations in force and/or the sales contract. At the moment of the first start-up, check that the burner is integral and complete.



Failure to observe the information given in this manual, operating negligence, incorrect installation and carrying out of non authorised modifications will result in the annulment by the manufacturer of the guarantee that it supplies with the burner.

In particular, the rights to the guarantee and the responsibility will no longer be valid, in the event of damage to things or injury to people, if such damage/injury was due to any of the following causes:

- incorrect installation, start-up, use and maintenance of the burner;
- improper, incorrect or unreasonable use of the burner;
- intervention of unqualified personnel;
- carrying out of unauthorised modifications on the equipment;
- use of the burner with safety devices that are faulty, incorrectly applied and/or not working;
- installation of untested supplementary components on the burner;
- powering of the burner with unsuitable fuels;
- faults in the fuel supply system;
- continuation of use of the burner when a fault has occurred;
- repairs and/or overhauls incorrectly carried out;
- modification of the combustion chamber with inserts that prevent the regular development of the structurally established flame;
- insufficient and inappropriate surveillance and care of those burner components most likely to be subject to wear and tear;
- the use of non-original components, including spare parts, kits, accessories and optional;
- force majeure.

The manufacturer furthermore declines any and every responsibility for the failure to observe the contents of this manual.

Riello warranty is subject to correct burner, appliance and application matching, and set up in line with Riello's instructions and guidelines. All components within the hydraulic circuit suitable for bio fuel use and supplied by Riello will be identified as Bio compatible. No warranty is given in relation to the use of components which are not so identified with bio fuel blends. If in any doubt please contact Riello for further advice.

If any Riello burners are used with fuel with a bio content >10% then the components within the hydraulic circuit maybe affected and are not covered under warranty.

The hydraulic circuit consists of:

- Pump
- Hydraulic ram (where applicable)
- Valve block
- Flexible oil lines (considered as a consumable component)

- 1 Irrespective of any warranty given by Riello in relation to normal use and manufacturing defects, when fuels not meeting the relevant standards are used, or where fuel storage issues have not been addressed correctly, or the equipment used is not compatible, if failures occur which are directly or indirectly attributed to such issues and/or to the non-observance of this guidance, then no warranty or liability is implied or accepted by Riello.
- 2 Riello have carefully chosen the specification of the bio compatible components including the flexible oil lines to protect the pump, safety valve and nozzle. The Riello warranty is dependent upon the use of Riello genuine components including the oil lines, being used.
- 3 Riello warranty does not cover defects arising from incorrect commissioning or servicing by non Riello employed service engineers, and any issues impacting the burner arising from external site related issues.

2.3 Guidance for the use of bio fuel blends up to 10% where gas oil use is permitted by the appliance Manufacturer

Background

With increasing focus on renewable and sustainable energy requirements, Bio fuel usage is set to increase. Riello is committed to promoting energy conservation and the use of renewable energy from sustainable resources including liquid bio fuels, however there are some technical aspects that must be considered at the planning stage of using such fuels to reduce the potential for equipment failure or the risks of fuel leakage.

Liquid Bio fuel is a generic description used for oil that can come from numerous feed stocks including recycled cooking oils. These types of oils have to be considered and treated differently from standard mineral or fossil fuels, as they are generally more acidic, hygroscopic and less stable.

Due to this, a holistic approach is needed from the specification of the liquid Bio fuel, the storage of the fuel, its oil supply line and ancillary equipment, and very importantly the oil filtration and the burner itself. The specification for FAME (Fatty Acids Methyl Ester) liquid Bio fuel is critical to reliable equipment operation.

It is a minimum requirement that the fuel blend (up to 10% Bio) is obtained with gasoil in accordance with the relevant EN standards, regional regulations and FAME in accordance with EN 14214. It is also important that the fuel blends meet the require-

ments related to operational environment conditions within the relevant EN standards.

When choosing your Riello oil products where you know Bio fuels will be in use, please make sure that a Bio compatible burner and/or components have been supplied. If an existing burner is to be used with a liquid Bio fuel then a kit may be required to make it compatible and the guidance notes enclosed concerning oil storage and filtration must be adhered to. The end user is responsible for the thorough verification of the potential risks associated with the introduction of a bio fuel blend and the suitability of the appliances and installation applicable.

Irrespective of any warranty given by Riello in relation to normal use and manufacturing defects, when fuels not meeting the relevant standards are used, or where fuel storage issues have not been addressed correctly, or the equipment used is not compatible, if failures occur which are directly or indirectly attributed to such issues and/or to the non-observance of this guidance, then no warranty or liability is implied or accepted by Riello.

2.3.1 Information and general instructions

To ensure consistency, the supplier of the fuel must be able to demonstrate compliance with a recognised Quality Control and management system to ensure high standards are maintained within the storage, blending and delivery processes.

The installation oil storage tank and its ancillaries must also be prepared BEFORE liquid Bio fuel is introduced.

Checks and preparation should include:

- For new installations, make sure that all materials and seals in the oil storage and supply line to the burner are compatible with Bio fuels. For all installations, there must be a good quality bio compatible oil filter at the tank and then a secondary filter of 60 Microns protecting the burner from contamination.
- If an existing oil storage tank is to be used then in addition to the materials checks as detailed above, it will be essential that the tank is first inspected for condition and checked for water or other contamination. Riello strongly recommends that the tank is cleaned and oil filters replaced prior to Bio fuel delivery. If this is not completed then due to the hydroscopic nature of Bio fuel, it will effectively clean the tank, absorb water present which in turn will result in equipment failure that is not covered by the manufacturer's warranty.
- Depending on the capacity of the oil storage tank and oil usage, fuels may remain static within the tank for some considerable time and so Riello recommends that the oil distributor is consulted regarding the use of additional Biocides within the fuel to prevent microbial growth from occurring within the tank. Riello suggests that fuel suppliers and or service companies are contacted for guidance on fuel filtration. Special attention should be applied to fuel applications where oil may be stored for long periods of time.
- The burner must be set according to the appliance application and commissioned checking that all combustion parameters are as recommended in the appliance technical manual.
- Riello recommends that the in line and burner oil pump filters are inspected and if required replaced at least every 4 months during burner use, before the burner start-up following a long period of discontinuous operation and even more frequently where contamination has occurred. Particular attention is needed when inspecting and checking for fuel leakages from seals, gaskets and hoses.

2.3.2 Product Disclaimer Statement

CAREFULLY READ THE FOLLOWING DISCLAIMER. YOU ACCEPT AND AGREE TO BE BOUND BY THIS DISCLAIMER BY PURCHASING RIELLO BIO COMPATIBLE BURNERS AND/OR COMPONENTS.

Although the information and recommendations (hereinafter "Information") in this guidance is presented in good faith, believed to be correct and has been carefully checked, Riello (and its subsidiaries) makes no representations or warranties as to the completeness or accuracy of the Information. Information is supplied upon the condition that the persons receiving same will make their own determination as to its suitability for their purposes prior to use. In no event will Riello (and its subsidiaries) be responsible for damages of any nature whatsoever resulting from the use of or reliance upon Information.

Other than set forth herein, Riello (and its subsidiaries) makes no additional warranties with respect to the bio compatible burner, either express or implied, including that of merchantability or fitness for a particular purpose or use.

In no event shall Riello (and its subsidiaries) be liable for any indirect, incidental, special or consequential damages including, without limitation, loss of profits, damages for loss of business profits, business interruption, loss of business information, loss of equipment, or other pecuniary loss or compensation for services whether or not it is advised of the possibility of such damages.

With the exception of injuries to persons, Riello's liability is limited to the customer's right to return defective/non-conforming products as provided by the relevant product warranty.

3 Safety and prevention

3.1 Introduction

The burners have been designed and built in compliance with current regulations and directives, applying the known technical rules of safety and envisaging all the potential danger situations. It is necessary, however, to bear in mind that the imprudent and clumsy use of the equipment may lead to situations of death risk for the user or third parties, as well as the damaging of the burner or other items. Inattention, thoughtlessness and excessive confidence often cause accidents; the same applies to tiredness and sleepiness.

It is a good idea to remember the following:

- The burner must only be used as expressly described. Any other use should be considered improper and therefore dangerous.

In particular:

it can be applied to boilers operating with water, steam, diathermic oil, and to other uses expressly named by the manufacturer;

the type and pressure of the fuel, the voltage and frequency of the electrical power supply, the minimum and maximum deliveries for which the burner has been regulated, the pressurisation of the combustion chamber, the dimensions of the combustion chamber and the room temperature must all be within the values indicated in the instruction manual.

- Modification of the burner to alter its performance and destinations is not allowed.
- The burner must be used in exemplary technical safety conditions. Any disturbances that could compromise safety must be quickly eliminated.
- Opening or tampering with the burner components is not allowed, apart from the parts requiring maintenance.
- only those parts detailed as available as spare parts by the manufacturer can be replaced.

3.2 Safety warnings

The dimension of the boiler's combustion chamber must respond to specific values, in order to guarantee a combustion with the lowest polluting emissions rate.

The Technical Service Personnel will be glad to give you all the information for a correct matching of this burner to the boiler.

This burner must only be used for the application it was designed for.

The manufacturer accepts no liability within or without the contract for any damage caused to people, animals and property due to installation, adjustment and maintenance errors or to improper use.

3.3 Basic safety rules

- Children or inexperienced persons must not use the appliance.
- Under no circumstances must the intake grids, dissipation grids and ventilation vents in the installation room be covered up with cloths, paper or any other material.
- Unauthorised persons must not attempt to repair the appliance.
- It is dangerous to pull or twist the electric leads.
- Cleaning operations must not be performed if the appliance is not disconnected from the main power supply.
- Do not clean the burner or its parts with inflammable substances (e.g. petrol, alcohol, etc.). The cover must be cleaned with soapy water.
- Do not place anything on the burner.
- Do not block or reduce the size of the ventilation vents in the installation room.
- Do not leave containers and inflammable products or combustible materials in the installation room.

3.4 Personnel training

The user is the person, body or company that has acquired the machine and intends to use it for the specific purpose. He is responsible for the machine and for the training of the people working around it.

The user:

- undertakes to entrust the machine exclusively to suitably trained and qualified personnel;
- must take all the measures necessary to prevent unauthorised people gaining access to the machine;
- undertakes to inform his personnel in a suitable way about the application and observance of the safety instructions. With that aim, he undertakes to ensure that everyone knows the use and safety instructions for his own duties;
- must inform the manufacturer if faults or malfunctioning of the accident prevention systems are noticed, along with any presumed danger situation.
- Personnel must always use the personal protective equipment envisaged by legislation and follow the indications given in this manual.
- Personnel must observe all the danger and caution indications shown on the machine.
- Personnel must not carry out, on their own initiative, operations or interventions that are not within their province.
- Personnel must inform their superiors of every problem or dangerous situation that may arise.
- The assembly of parts of other makes, or any modifications, can alter the characteristics of the machine and hence compromise operating safety. The manufacturer therefore declines any and every responsibility for any damage that may be caused by the use of non-original parts.

4 Technical description of the burner

4.1 Technical data

Type	489 T50	488 T50
Output - Thermal power (with air at 20 °C)	3.0 - 5.8 kg/h 35.6 - 68.7 kW	4.7 - 9.5 kg/h 55.7 - 113 kW
Fuel	Kerosene, viscosity 1.6 – 6 mm ² /s at 20 °C (H _i = 11.97 kWh/kg) Gas oil, viscosity 4 – 6 mm ² /s at 20 °C ◆ (H _i = 11.86 kWh/kg)	
Electrical supply	Single phase, ~ 50Hz 230 V ± 10%	
Motor	Run current 1.3 A – 2750 rpm – 288 rad/s	
Capacitor	5 µF	
Ignition transformer	Secondary 8 kV – 16 mA	
Pump	Kerosene, maximum pressure 10 bar (145 psi) Gas oil, maximum pressure 15 bar (218 psi)	
Absorbed electrical power	0.16 kW	

◆ Gas oil is not permitted on low level discharge of flue gas products.

Tab. A

4.2 Burner description

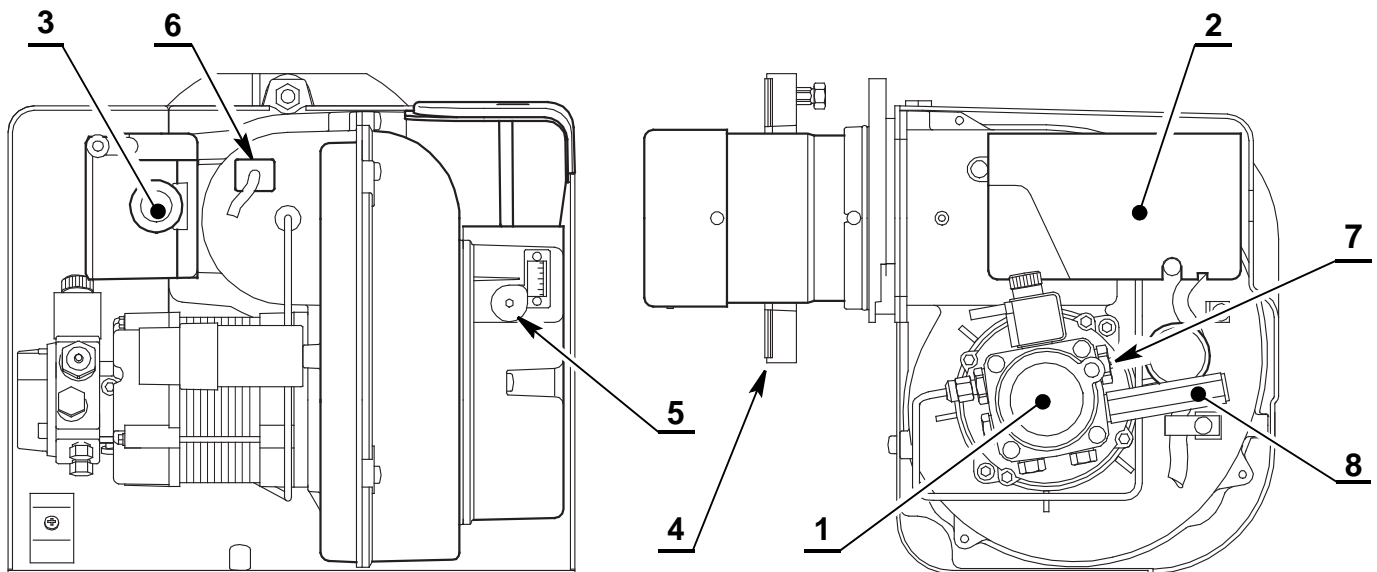

Fig. 1

- | | | | |
|---|---------------------------------|---|--------------------------------|
| 1 | Pump | 5 | Air damper adjustment screw |
| 2 | Control-box | 6 | Photoresistance |
| 3 | Reset button with lock-out lamp | 7 | Pump pressure adjustment screw |
| 4 | Flange with insulating gasket | 8 | Pressure gauge port |

4.3 Burner equipment

Flange with insulating gasket.....	No. 1
Bolts for flange to be fixed to boiler.....	No. 4
Screw and nuts for flange	No. 1
Hoses with nipples	No. 1
Screw of by-pass pump.....	No. 1
Hexagonal key	No. 1
Screws and terminal screw for feeding cable.....	No. 3



The hoses supplied with this burner set for Kerosene use are not suitable for use with Gas oil containing a Bio blend.

Please refer to the spare part list for the specific hoses suitable for bio fuel use.

In case of use with gas oil containing up to 10% Bio blend, it will be essential to use flexible oil lines suitable for bio fuel use.

Please contact Riello for further information.

4.4 Burner dimensions

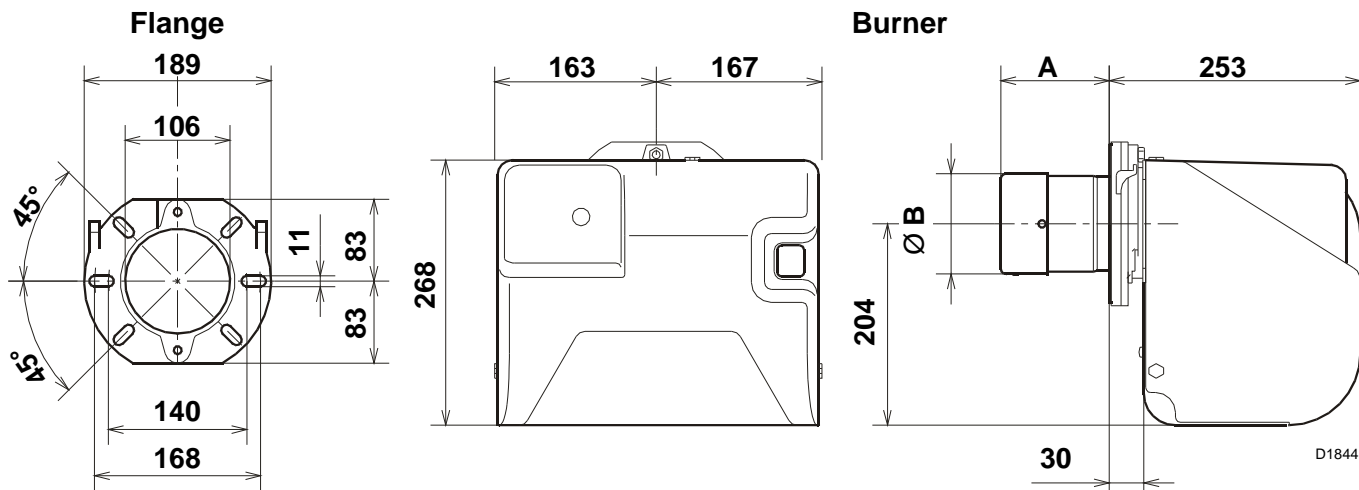

Fig. 2

	489T50	488T50
A	78	111
Ø B	88	105

4.5 Firing rates

The **MAXIMUM OUTPUT** is chosen from within the diagram area (Fig. 3).

The **MINIMUM OUTPUT** must not be lower than the minimum limit of the diagram.

The burner delivery must be selected within area of the diagrams (Fig. 3). This area is called firing rates and provides the maximum delivery of the burner in relation to the pressure in the combustion chamber.

The work point may be found by plotting a vertical line from the desired delivery and a horizontal line from the pressure in the combustion chamber. The intersection of these two lines is the work point which must lie within the firing rates.



The firing rate area values have been obtained considering a surrounding temperature of 20 °C, and an atmospheric pressure of 1013 mbar (approx. 0 m above sea level) and with the combustion head adjusted as shown on page 19.

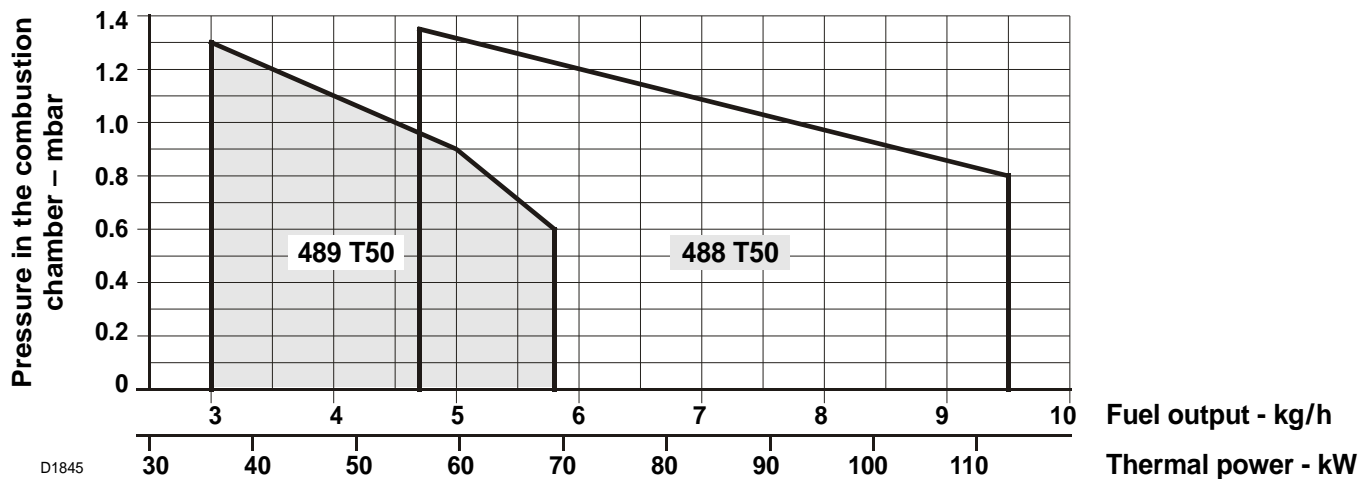

Fig. 3

5 Installation

5.1 Notes on safety for the installation

After carefully cleaning all around the area where the burner will be installed, and arranging the correct lighting of the environment, proceed with the installation operations.



All the installation, maintenance and disassembly operations must be carried out with the electricity supply disconnected.



The installation of the burner must be carried out by qualified personnel, as indicated in this manual and in compliance with the standards and regulations of the laws in force.

5.2 Handling

The packaging of the burner includes a carton box, so it is possible to move the burner (still packaged) with a transpallet truck or fork lift truck.



The handling operations for the burner can be highly dangerous if not carried out with the greatest attention: keep any unauthorised people at a distance; check the integrity and suitability of the available means of handling. Check also that the area in which you are working is empty and that there is an adequate escape area (i.e. a free, safe area to which you can quickly move if the burner should fall). When handling, keep the load at not more than 20-25 cm from the ground.



After positioning the burner near the installation point, correctly dispose of all residual packaging, separating the various types of material. Before proceeding with the installation operations, carefully clean all around the area where the burner will be installed.

5.3 Preliminary checks

Checking the consignment



After removing all the packaging, check the integrity of the contents. In the event of doubt, do not use the burner; contact the supplier.



The output of the burner must be within the boiler's firing rate;



The packaging elements (wooden cage or cardboard box, nails, clips, plastic bags, etc.) must not be abandoned as they are potential sources of danger and pollution; they should be collected and disposed of in the appropriate places.



A burner label that has been tampered with, removed or is missing, along with anything else that prevents the definite identification of the burner makes any installation or maintenance work difficult.

Checking the characteristics of the burner

R.B.L.	A		B	G
D	C	D ≤	G	
B	E			
F				
RIELLO S.p.A. I-37045 Legnago (VR)				CE xxxx

Fig. 4

Check the identification label of the burner, showing:

- the model **A**(Fig. 4) and type of burner **B**);
- the year of manufacture, in cryptographic form **C**);
- the serial number **D**);
- the electrical input power **E**);
- the types of fuel used and the relative supply pressures **F**);
- the data of the burner's minimum and maximum output possibilities **G**)(see Firing rate)

5.4 Installer/Service notes for the use of Gas oil with Bio blends up to 10% where gas oil use is permitted by the appliance Manufacturer

- During the burner installation, check that the gasoil and bio fuel blends are in accordance with Riello specifications (please refer to the chapters "Technical Data" and "Guidance for the use of bio fuel blends up to 10%" within the burner technical manual).
- If a Bio blend is in use the installer must seek information from the end user that their fuel supplier can evidence that the blends of fuel conform to the relevant standards.
- Check that the materials used in the construction of the oil tank and ancillary equipment are suitable for bio fuels, If not these must be upgraded or replaced with Bio compatible parts.
- Particular attention should be given to the oil storage tank and supply to the burner. Riello recommends that existing oil storage tanks are cleaned, inspected and any traces of water are removed BEFORE bio fuel is introduced (Contact the tank manufacturer or oil supplier for further advice). If these recommendations are not respected this will increase the risk of contamination and possible equipment failure.
- In line oil filters should be replaced making sure that they are Bio compatible. Riello recommends a good quality bio compatible oil filter at the tank and a secondary 60 micron filter are used to protect the burner pump and nozzle from contamination.
- The burner hydraulic components and flexible oil lines must be suitable for bio fuel use (check with Riello if in doubt). Riello have carefully chosen the specification of the bio compatible components including the flexible oil lines to protect the pump, safety value and nozzle. The Riello warranty is dependent upon the use of Riello genuine components including the oil lines, being used. The burner must be commissioned and combustion parameters set to appliance manufacturer's recommendations.
- Regularly check visually for any signs of oil leakage from seals, gaskets and hoses.
- It is strongly recommended that with Bio fuel use, oil filters are inspected and replaced every 4 months. More regularly where contamination is experienced.
- During extended periods of non operation and/or where burners are using oil as a standby fuel, it is strongly recommended that the burner is put into operation for shorts periods at least every three months.

5.5 Working position



The burner is designed to operate only in the positions **1**, and **3** (Fig. 5). Installation **1** is preferable, as it is the only one that allows performing maintenance operations as described in this manual. Installations **2**, **3** and **4** allow working operations but not maintenance with hooking to the boiler.



Any other position could compromise the correct operation of the appliance. Installation **5** is forbidden for safety reasons.

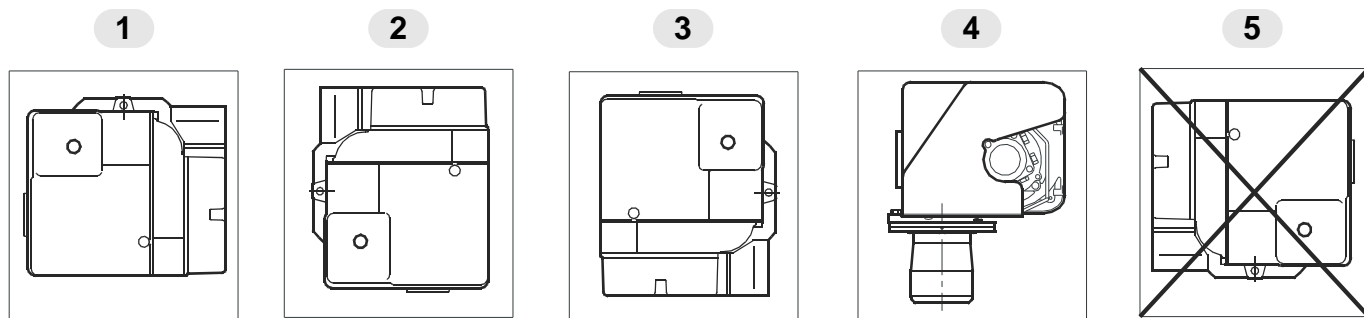

D4618

Fig. 5

5.6 Boiler fixing

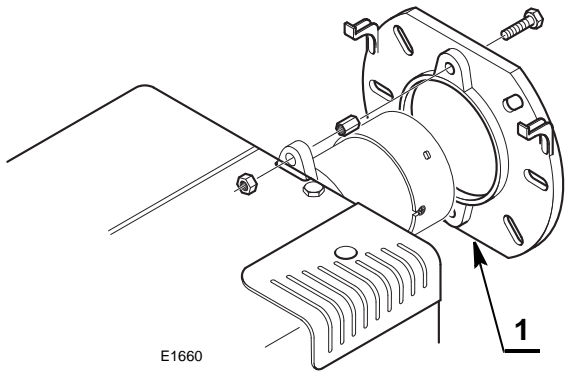

Fig. 6

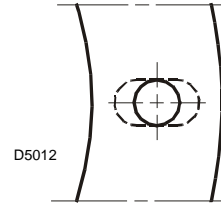

Fig. 7

- Put on the flange 1)(Fig. 6) the screw and two nuts.
- Widen, if necessary, the insulating gasket holes (5), (see Fig. 7).
- Fix the flange 1)(Fig. 8) to the boiler door 4) using screws 2) and (if necessary) the nuts 3) interposing the insulating gasket 5).



The seal between burner and boiler must be airtight.

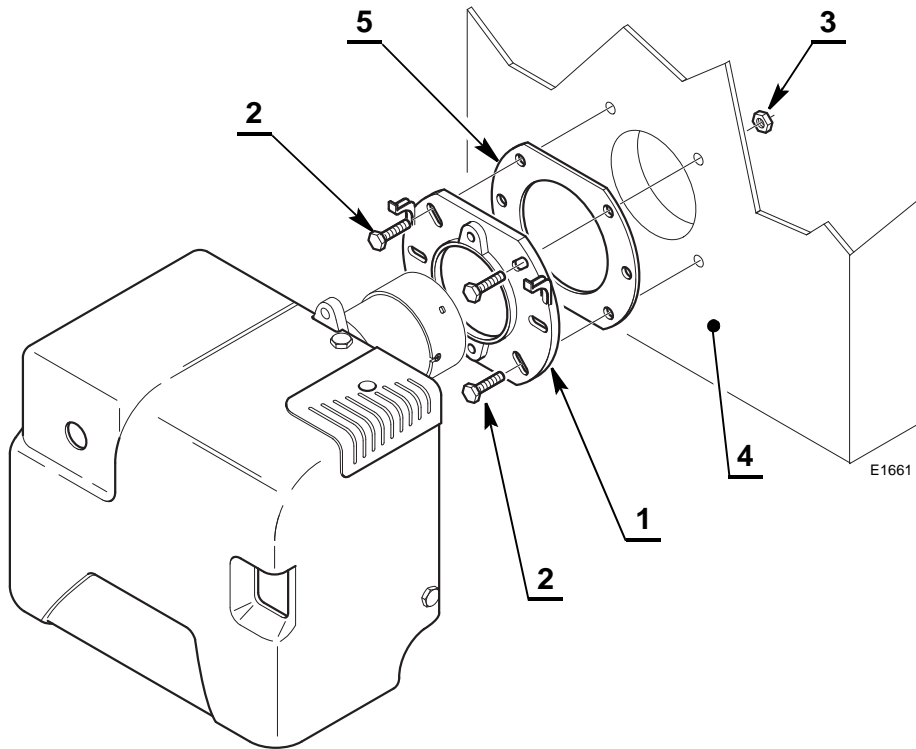

Fig. 8

5.7 Burner assembly

CF Application

In case of **CF** applications, the burner shall not operate without protection **(A)** of the suction inlet.

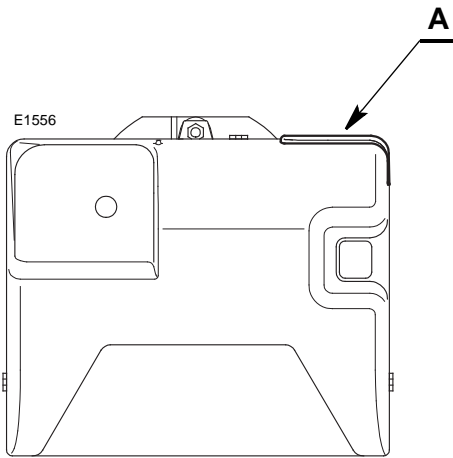

Fig. 9

BF Application



The temperature of the incoming air must not exceed 70 °C.



For correct BF application, the burner must be installed on an appropriate BF boiler.

In case of **BF** applications an optional snorkel and gasket are available replacing **(A)** with **(B)**. This item can be supplied separately.

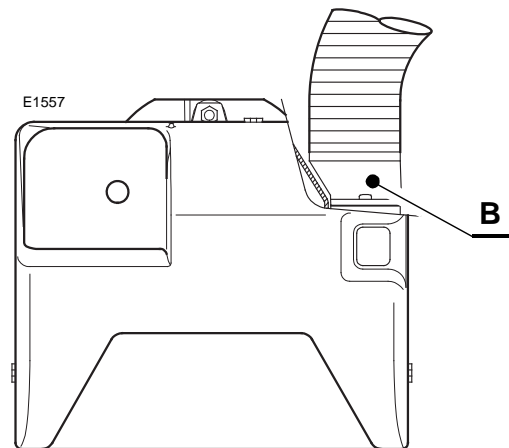

Fig. 10

6 Hydraulic systems

6.1 Fuel supply

6.1.1 Pump

The pump is designed to allow working with one pipe.

In order to obtain two pipes working it is necessary to unscrew the return plug 2)(Fig. 11), screw the by-pass screw 3),supplied as burner equipment and then screw the return hose.

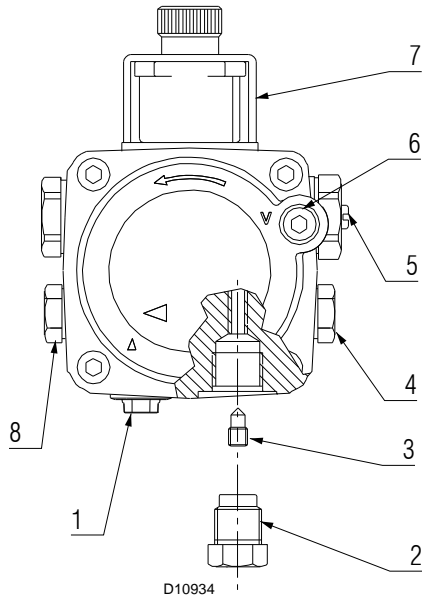

Fig. 11

Key (Fig. 11)

- | | |
|--------------------|---------------------------------|
| 1 Suction line | 5 Pressure adjuster |
| 2 Return line | 6 Vacuum gauge connection |
| 3 By-pass screw | 7 Valve |
| 4 Gauge connection | 8 Auxiliary pressure test point |



Where gas oil containing bio diesel is in use, it is recommended to avoid over oxygenation of the blended fuels.

Where at all possible avoid the use of two pipe systems where the circulated fuel is returned to the tank.

If this cannot be avoided make sure that the return pipe is normally below the surface of the fuel level within the storage tank. See Fig. 14.



The suction plug 1) is made of plastic. Once removed, it must not be used again.

In single pipe installations, the plug in the return line 2) must be totally in steel.



In case of use with gas oil containing up to 10% Bio blend, it will be essential to use flexible oil lines suitable for bio fuel use.

Please contact Riello for further information.

6.2 One pipe system

Pressurised one pipe systems (Fig. 12) have a positive fuel pressure on intake to the burner.

Usually the tank is higher than the burner, or the fuel pumping systems are on the outside of the boiler.

Vacuum one pipe systems (Fig. 13) have a negative fuel pressure (depression) on intake to the burner.

Usually the tank is lower than the burner.



You are advised to use additional filters on the fuel supply line.

Riello recommends a good quality fuel filter at the tank (Fig. 12 - Fig. 13) and a secondary filter (60 μ for gas oil and 15 μ for kerosene) are used to protect the burner pump and nozzle from contamination.

In case of Biodiesel use, pay attention to install Biocompatible filters.

6.2.1 Priming pump

On the system in Fig. 12 it is sufficient to loosen the plug of the vacuum gauge 6)(Fig. 11) and wait until the fuel flows out.

On the system in Fig. 13 start the burner and wait for the priming. Should lock-out occur prior to the arrival of the fuel, await at least 20 seconds before repeating the operation.



The installer must ensure that the supply pressure is not above 0.5 bar.

Above that level, the pump seal is subject to too much stress.

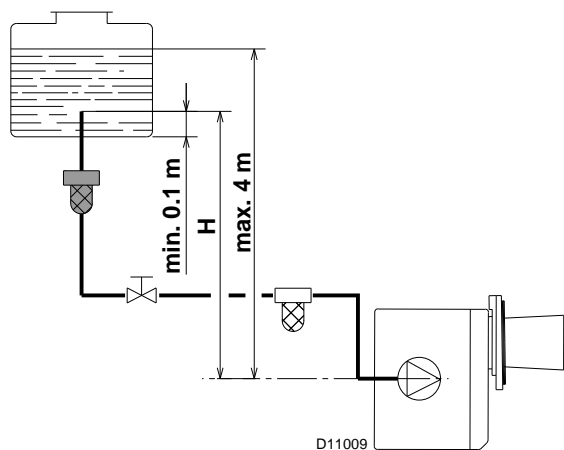

Fig. 12

H metres	L metres	
	I.D. (8 mm)	I.D. (10 mm)
0.5	10	20
1	20	40
1.5	40	80
2	60	100

Tab. B

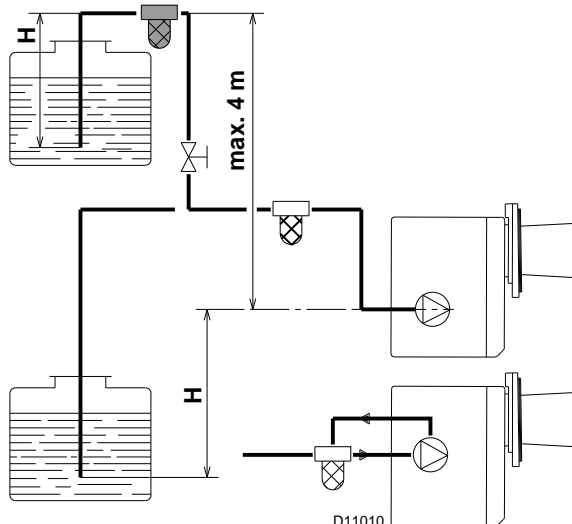

Fig. 13

H metres	L metres	
	I.D. (8 mm)	I.D. (10 mm)
0	35	100
0.5	30	100
1	25	100
1.5	20	90
2	15	70
3	8	30
3.5	6	20

Tab. C

- H difference of level
- L max. length of the suction line
- I.D. interterminal diameter of the oil pipes

NOTE:

The Tab. B and Tab. C show the maximum approximate lengths for the supply line, depending on the difference in level, length, and the diameter of the fuel conduit.

6.3 Two pipe system

Vacuum two pipe systems (Fig. 14) have a negative fuel pressure (depression) on intake to the burner. Usually the tank is lower than the burner.

The return line should terminate in the oil tank at the same level as the suction line; in this case a non-return valve is not required.

Should however the return line arrives over the fuel level, the non-return valve is indispensable. This solution however is less safe than previous one, due to the possibility of leakage of the valve.



You are advised to use additional filters on the fuel supply line.

Riello recommends a good quality fuel filter at the tank (Fig. 14) and a secondary filter (60 μ for gas oil and 15 μ for kerosene) are used to protect the burner pump and nozzle from contamination.

In case of Biodiesel use, pay attention to install Biocompatible filters.

6.3.1 Priming pump



Before starting the burner make sure that the return pipe-line is not clogged: any obstruction would cause the pump seals to break.

On the system in Fig. 14 start the burner and wait for the priming. Should lock-out occur prior to the arrival of the fuel, await at least 20 seconds before repeating the operation.



The pump vacuum should not exceed a maximum of 0.4 bar (30 cm Hg). Beyond this limit gas is released from the oil.

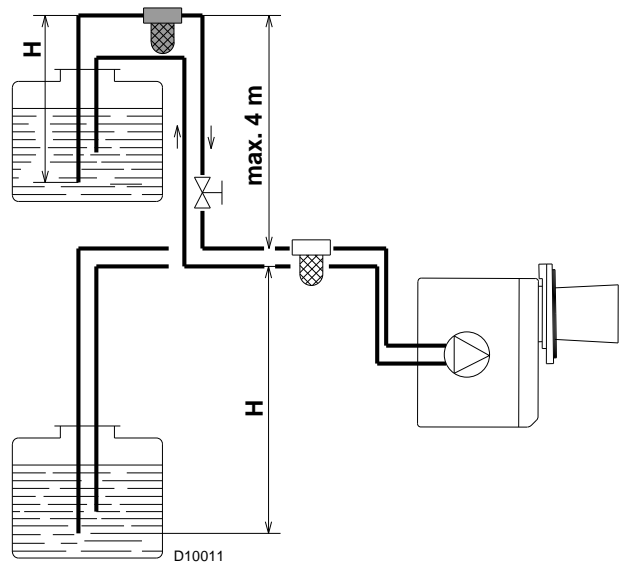

Fig. 14

H metres	L metres	
	I.D. (8 mm)	I.D. (10 mm)
0	35	100
0.5	30	100
1	25	100
1.5	20	90
2	15	70
3	8	30
3.5	6	20

Tab. D

H difference of level

L max. length of the suction line

I.D. interterminal diameter of the oil pipes

NOTE:

The Tab. D shows the maximum approximate lengths for the supply line, depending on the difference in level, length, and the diameter of the fuel conduit.

7 Electrical system

7.1 Notes on safety for the electrical wiring



DANGER

- The electrical wiring must be carried out with the electrical supply disconnected.
- Electrical wiring must be carried out by qualified personnel and in compliance with the regulations currently in force in the country of destination. Refer to the wiring diagrams.
- The manufacturer declines all responsibility for modifications or connections different from those shown in the wiring diagrams.
- Do not invert the neutral with the phase in the electrical supply line. Any inversion would cause a lockout due to firing failure.
- Check that the electrical supply of the burner corresponds to that shown on the identification label and in this manual.
- The burners have been set for intermittent operation. This means they should compulsorily be stopped at least once every 24 hours to enable the control box to perform checks of its own start-up efficiency. Normally the boiler's thermostat/pressure switch ensures the stopping of the burner.
If this is not the case, it is necessary to apply in series with IN a timer switch that turns off the burner at least once every twenty-four hours. Refer to the wiring diagrams.
- The electrical safety of the device is obtained only when it is correctly connected to an efficient earthing system, made according to current standards. It is necessary to check this fundamental safety requirement. In the event of doubt, have the electrical system checked by qualified personnel.
- The electrical system must be suitable for the maximum input power of the device, as indicated on the label and in the manual, checking in particular that the section of the cables is suitable for the input power of the device.
- For the main power supply of the device from the electricity mains:
 - do not use adapters, multiple sockets or extensions;
 - use an omnipolar switch, as indicated by the current safety standards.
- Do not touch the device with wet or damp body parts and/or in bare feet.
- Do not pull the electric cables.

Before carrying out any maintenance, cleaning or checking operations:



DANGER

disconnect the electrical supply from the burner by means of the main system switch;



DANGER

isolate the fuel supply

If the cover is still present, remove it and proceed with the electrical wiring according to the wiring diagrams.

Use flexible cables in compliance with the EN 60 335-1 standard.

7.2 Electrical wiring

~ 50Hz - 230V

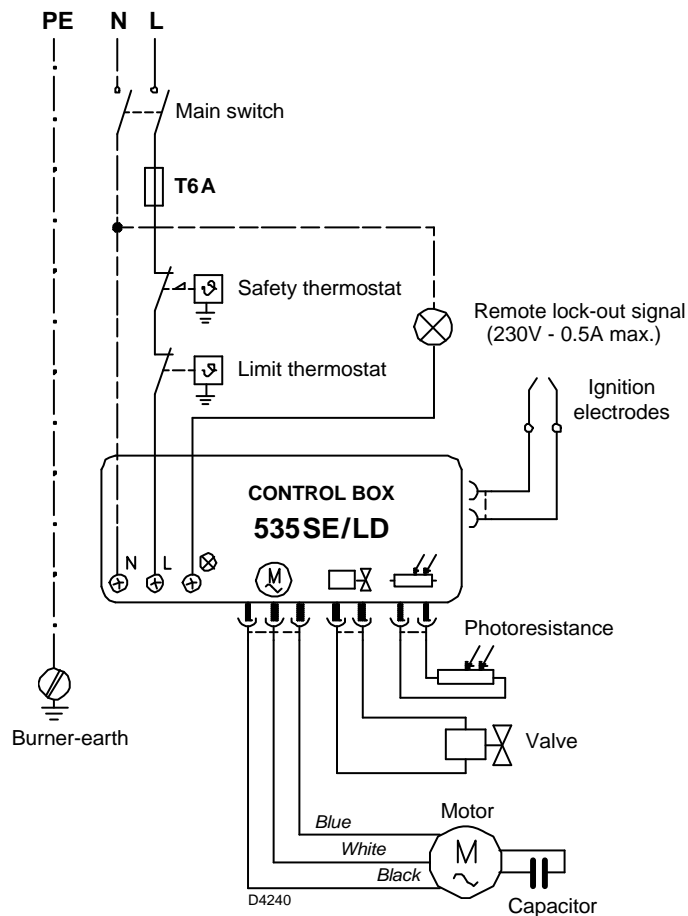

Fig. 15



WARNING

- Do not swap neutral and phase over, follow the diagram shown carefully and carry out a good earth connection.
- The electrical wiring carried out by the installer must be in compliance with the rules in force in the country.
- The section of the conductors must be at least 1mm². (Unless requested otherwise by local standards and legislation).

TESTING:

Check the shut-down of the burner by opening the thermostats and the lock-out by darkening the photoresistance.

7.2.1 Control box



DANGER

This operation must be performed with the burner turned off and mains power disconnected.

To remove the control box (Fig. 16) from the burner follow of the instruction:

- Loosen the screw 1), open the protection 2) and remove all components.
- Remove the coil 3).
- Loosen the two screws 4).
- Move a little the control box and remove the high voltage leads.

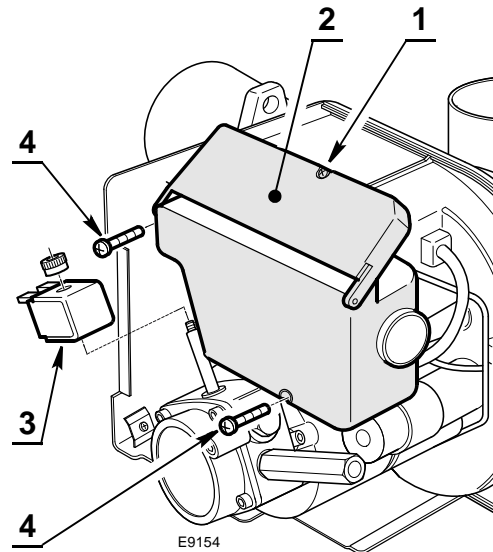

Fig. 16

8 Start-up, calibration and operation of the burner

8.1 Notes on safety for the first start-up



The first start-up of the burner must be carried out by qualified personnel, as indicated in this manual and in compliance with the standards and regulations of the laws in force.



Check the correct working of the adjustment, command and safety devices.

8.2 Combustion adjustment

In conformity with Efficiency Directive 92/42/EEC the application of the burner on the boiler, adjustment and testing must be carried out observing the instruction manual of the boiler, including verification of the CO and CO₂ concentration in the flue gases, their temperatures and the average temperature of the water in the boiler.



Combustion air is drawn in from outside, meaning there may be notable changes in temperature, which can affect the percentage of CO₂. You are advised to adjust CO₂ in accordance with the graph featured. Example: outside air temperature 10 °C, adjust CO₂ to 11.6% (± 0.2%).

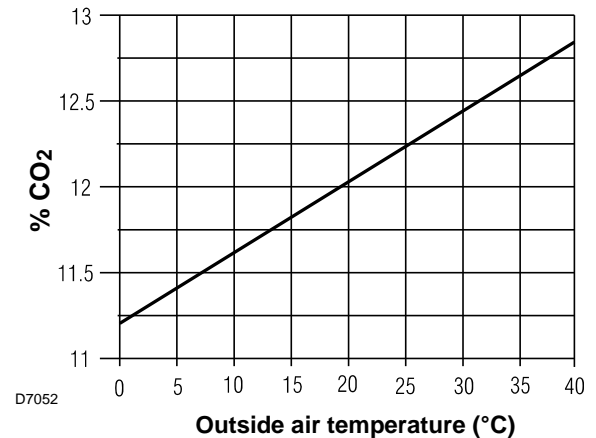

Fig. 17

	Nozzle	GPH	Angle	Pump pressure bar	Burner output kg/h ± 4%	Combustion head adjustment	Air damper adjustment
						Set-point	Set-point
489 T50	GAS OIL	0.75	60°	12	3.0	0.5	1.0
		0.85	60°	12	3.4	0.5	1.4
		1.00	60°	12	4.0	1.5	2.0
		1.10	60°	12	4.4	3.0	2.6
		1.25	60°	12	5.0	4.5	3.0
		1.35	60°	13	5.6	6.0	4.0
	KEROSENE	1.10	60°	7	3.08	0.0	1.1
		1.25	60°	8	3.74	0.0	1.4
		1.35	60°	8	4.04	0.5	1.9
		1.50	60°	8	4.49	1.5	2.2
		1.65	60°	8	4.93	3.0	2.5
		1.75	60°	8	5.23	4.5	3.1
		1.75	60°	10	5.85	6.0	4.0

Tab. E

	Nozzle	Pump pressure	Burner output	Combustion head adjustment	Air damper adjustment			
						GPH	Angle	bar
488 T50	GAS OIL		1.10	60°	12	4.4	2.0	2.8
			1.25	60°	12	5.0	2.5	3.4
			1.35	60°	12	5.4	2.5	3.7
			1.50	60°	12	6.0	3.0	4.3
			1.65	60°	12	6.6	3.0	5.0
			1.75	60°	12	7.0	3.5	5.5
			2.00	60°	12	8.0	4.0	7.5
	KEROSENE		1.65	60°	7	4.65	2.0	2.8
			1.75	60°	8	5.23	2.5	3.1
			2.00	60°	8	5.98	2.5	3.9
			2.25	60°	8	6.73	3.0	5.1
			2.50	60°	8	7.48	3.5	5.9
			2.75	60°	8	8.22	4.0	7.4
			3.00	60°	9	9.51	5.0	8.5

Tab. F

8.3 Nozzles installation

The burner complies with the emission requirements of the EN 267 standard.

In order to guarantee that emissions do not vary, recommended and/or alternative nozzles specified by the manufacturer in the Instruction and warning booklet should be used.



It is advisable to replace nozzles every year during regular maintenance operations.



The use of nozzles other than those specified by the manufacturer and inadequate regular maintenance may result into emission limits non-conforming to the values set forth by the regulations in force, and in extremely serious cases, into potential hazards to people and objects.

The manufacturing company shall not be liable for any such damage arising from nonobservance of the requirements contained in this manual.

8.3.1 Nozzles recommended

- Hago type ES - B;
- Delavan type W - B;
- Steinen type S;
- Danfoss type S.

Angle 60°: in most cases.

Angle 80°: in case of flame detachment, during ignitions at low temperatures.

8.4 Pump pressure

The pump leaves the factory set for kerosene working.

10 bar: maximum pressure for kerosene.

For gas oil increase pressure

12 bar: pressure suitable for gas oil in most cases.

14 bar: improves flame retention; it is therefore suitable for ignitions at low temperatures.

8.5 Maintenance position

Access to the combustion head, electrodes and nozzle.

- Remove the burner out of the boiler, after loosing the fixing nut to the flange.
- Hook the burner to the flange (1), by removing the blast tube (2) after loosing the fixing screws (3).
- Remove the electrodes assembly (5) from the nozzle holder (4) after loosing its fixing screw (A, Fig. 20).
- Screw the nozzle (6).

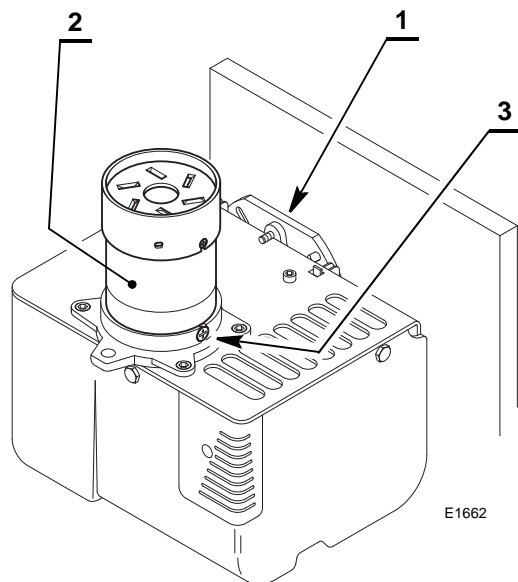

Fig. 18

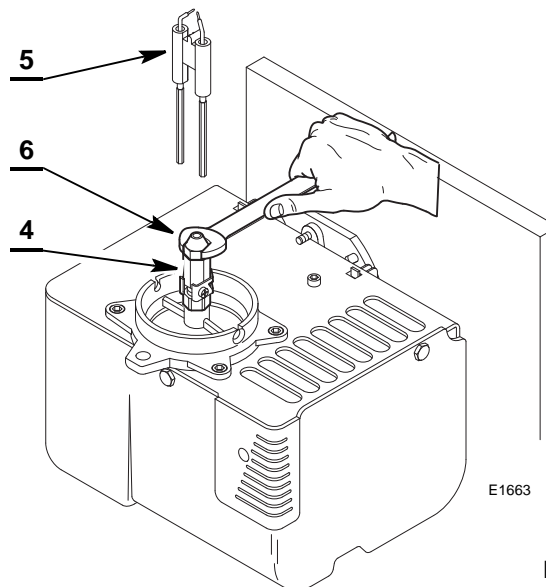

Fig. 19

8.6 Air damper adjustment

The settings indicated in the schedule refer to the combustion-chamber with “zero” depression. This regulation is purely indicative.

Each installation however, has its own unpredictable working conditions: actual nozzle output; positive or negative pressure in the combustion-chamber, the need of excess air, etc.

All these conditions may require a different air damper setting.

8.7 Electrodes setting



The position of the electrodes cannot be regulated. In case of failure, check that the measurements as shown on the figure are respected.

Before removing or assembling the nozzle, loosen the screw (A, Fig. 20) and move the electrodes ahead.

TYPE	D
489T50	2 – 2.5 mm
488T50	4 ± 0.5 mm

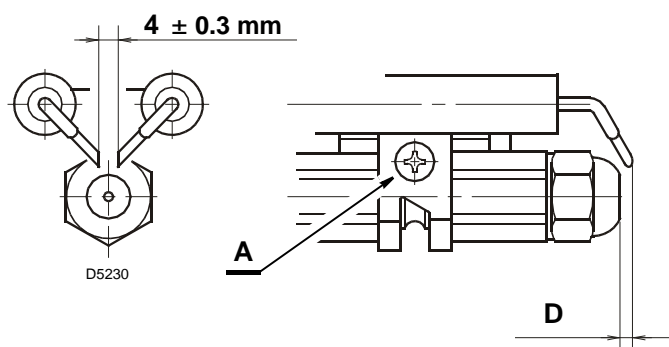

Fig. 20

8.8 Combustion head setting

This is done when fitting the nozzle, with the blast tube removed. It depends on the output of the burner and is carried out by rotating the regulating rod, till the terminal plane of the blast tube is level with the set-point, as indicated in the schedule.

489 T50

In the sketch on the left, the combustion head is set for an output of 1.65 GPH at 8 bar (for kerosene) or 1.10 GPH at 12 bar (for gas oil).

488 T50

In the sketch on the left, the combustion head is set for an output of 1.50 GPH at 12 bar (for gas oil) or 2.25 GPH at 8 bar (for kerosene).

The shutter is level with set-point 3, as required by the schedule at page 19.

Combustion head settings indicated in the schedule are valid for most cases.

The setting of the fan output according to the installation should normally be done only through the air damper.

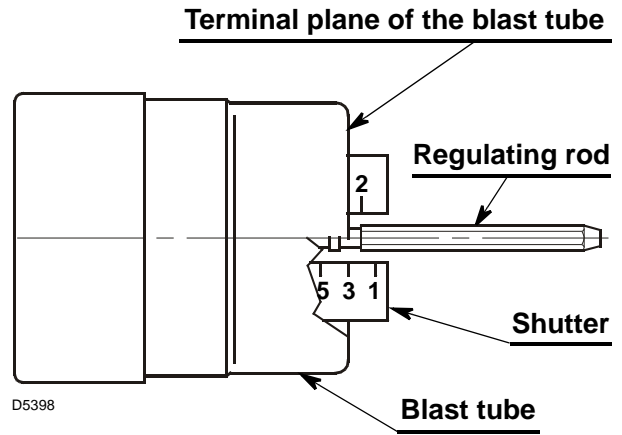

Fig. 21

8.9 Burner start-up cycle

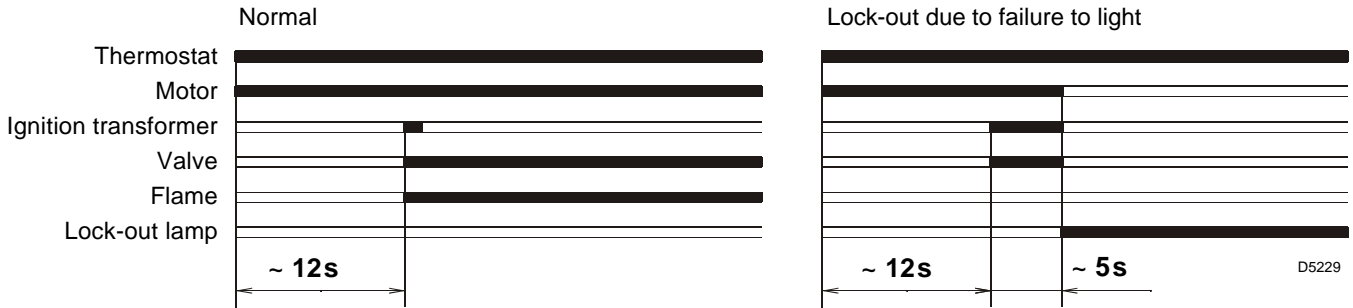

Fig. 22

Lock out is indicated by a lamp on the control box (3, Fig. 1 to page 8)

9 Maintenance

9.1 Notes on safety for the maintenance

The periodic maintenance is essential for the good operation, safety, yield and duration of the burner.

It allows you to reduce consumption and polluting emissions and to keep the product in a reliable state over time.



The maintenance interventions and the calibration of the burner must only be carried out by qualified, authorised personnel, in accordance with the contents of this manual and in compliance with the standards and regulations of current laws.

Before carrying out any maintenance, cleaning or checking operations:



disconnect the electricity supply from the burner by means of the main switch of the system;



isolate the fuel supply.

9.2 Maintenance programme

9.2.1 Maintenance frequency

The combustion system should be checked at least once a year by a representative of the manufacturer or another specialised technician.

9.2.2 Checking and cleaning

Combustion head

Open the burner and make sure that all components of the combustion head are in good condition, not deformed by the high temperatures, free of impurities from the surroundings and correctly positioned.

Clean the combustion head in the fuel exit area, on the diffuser disc.

Burner

Check for excess wear or loose screws and clean the outside of the burner.

Fan

Check to make sure that no dust has accumulated inside the fan or on its blades, as this condition will cause a reduction in the air flow rate and provoke polluting combustion.

Photoresistance

Clean the photoresistance.

Electrodes

Check the correct position of electrodes

Nozzles

It is advisable to replace nozzles every year during regular maintenance operations.

Do not clean the nozzle openings; do not even open them.

Filters

Check the filtering baskets on line and at nozzle present in the system. Clean or replace if necessary.

If rust or other impurities are observed inside the pump, use a separate pump to lift any water and other impurities that may have deposited on the bottom of the tank.

Pump

Delivery pressure must correspond with the table on Tab. E to page 19. Please check that the supply line and filters are clear. The use of a pump vacuum gauge will assist in this. This measure permits the cause of the anomaly to be traced to either the suction line or the pump.

If the problem lies in the suction line, check to make sure that the filter is clean and that air is not entering the piping.

Hoses

- Check periodically the flexible pipes conditions. They have to be replaced at least **every 2 years**.
- In case of use of gas oil and bio fuel blends, it is strongly recommended to inspect **even more frequently** the hoses and replace them where contamination has occurred.
- Check to make sure that the hoses are still in good condition.



The hoses supplied with this burner set for Kerosene use are not suitable for use with Gas oil containing a Bio blend.

Please refer to the spare part list for the specific hoses suitable for bio fuel use.

In case of use with gas oil containing up to 10% Bio blend, it will be essential to use flexible oil lines suitable for bio fuel use.

Please contact Riello for further information.

Fuel tank

If water or contamination is present within the fuel tank, it is essential that this is removed before the equipment is to be used. This is extremely important when gas oil containing Bio diesel is in use. If in doubt about how to achieve this then please contact the fuel or oil tank supplier.

Boiler

Clean the boiler as indicated in the appliance accompanying instructions in order to maintain all the original combustion characteristics intact, especially the flue gas temperature and combustion chamber pressure.

Combustion

In case the combustion values found at the beginning of the intervention do not respect the standards in force or, in any case, do not correspond to a proper combustion, contact the Technical Assistant and have him carry out the necessary adjustments.

Allow the burner to work for 10 min. and then check the combustion readings with the parameters indicated within the appliance instruction manual. **Then carry out a combustion check verifying:**

- Smoke temperature at the chimney;
- Content of CO₂ (%);
- Content of CO (ppm);
- Smoke value according to opacity smokes index according to Bacharach scale.

10 Faults / Solutions

Here below you can find some causes and the possible solutions for some problems that could cause a failure to start or incorrect operation of the burner.

A fault usually makes the lock-out lamp light which is situated inside the reset button of the control box (3, Fig. 1 to page 8).

When lock out lamp lights the burner will attempt to light only after pushing the reset button. After this if the burner functions correctly, the lock-out can be attributed to a temporary fault.

If however the lock out continues the cause must be determined and the solution found.

FAULTS	POSSIBLE CAUSES	SOLUTION
The burner will not start when the limit thermostat closes.	Lack of electrical supply.	Check presence of voltage in the L - N clamps of the control box. Check the conditions of the fuses. Check that safety thermostat limit is not lock out.
	The photoresistance sees false light.	Eliminate the light.
	The connections in the control box are wrongly inserted.	Check and connect completely all the plugs.
Burner runs normally in the prepurge and ignition cycle and locks out after 5 seconds ca.	The photoresistance is dirty.	Clean it.
	The photoresistance is defective.	Change it.
	Flame moves away or fails.	Check pressure and output of the fuel. Check air output. Change nozzle. Check the coil of solenoid valve.
Burner starts with an ignition delay.	The ignition electrodes are wrongly positioned.	Adjust them according to the instructions of this manual.
	Air output is too high.	Set the air output.
	Nozzle dirty or worn.	Replace it.



The manufacturer cannot accept responsibility for any damage to persons, animals or property due to error in installation or in the burner adjustment, or due to improper or unreasonable use or non observance of the technical instruction enclosed with the burner, or due to the intervention of un-qualified personnel.



RIELLO S.p.A.
I-37045 Legnago (VR)
Tel.: +39.0442.630111
[http:// www.rielloburners.com](http://www.rielloburners.com)

EN

1. GENERAL INSTRUCTIONS

- Carefully read the instructions contained in this instruction booklet.
- After boiler installation, inform the user regarding its operation and give him this manual, which is an integral and essential part of the product and must be kept with care for future reference.
- Installation and maintenance must be carried out by professionally qualified personnel, according to current regulations and the manufacturer's instructions. Do not carry out any operation on the sealed control parts.
- Incorrect installation or inadequate maintenance can result in damage or injury. The Manufacturer declines any liability for damage due to errors in installation and use or failure to follow the instructions.
- Before carrying out any cleaning or maintenance operation, disconnect the unit from the power supply using the system switch and/or the special cut-off devices.
- In case of a fault and/or poor operation, deactivate the unit and do not attempt to repair it or directly intervene. Contact professionally qualified personnel. Repair/replacement of the products must only be carried out by professionally qualified using original spare parts. Failure to comply with the above could affect the safety of the unit.
- This unit must only be used for its intended purpose. Any other use is considered improper and therefore dangerous.
- The packing materials are potentially hazardous and must not be left within the reach of children.
- The images given in this manual are a simplified representation of the product. In this representation there may be slight and insignificant differences with respect to the product supplied.

2. OPERATING INSTRUCTIONS

2.1 Introduction

Dear Customer,

Thank you for choosing a **FERROLI** boiler featuring advanced design, cutting-edge technology, high reliability and quality construction. Please read this manual carefully since it provides important information on safe installation, use and maintenance.

ATLAS is a high-efficiency heat generator for the production of heating hot water, suitable for operation with blown oil or gas burners. The boiler shell consists of cast iron elements, assembled with steel stays and double cones, whose profile is specially designed with optimum division of the fins, offering high thermal efficiency and therefore high energy-saving.

2.2 Control panel

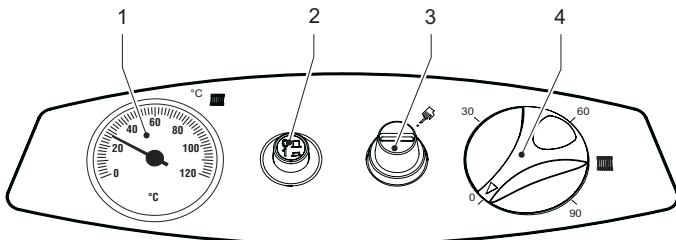

fig. 1 - Control panel for models ATLAS 32-78

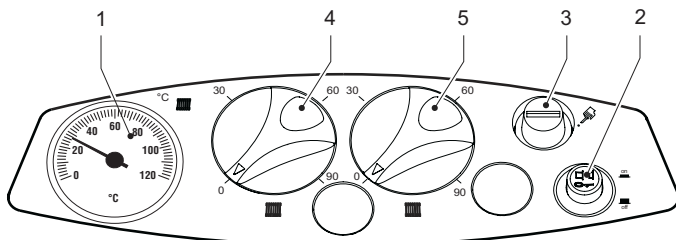

fig. 2 - Control panel for models ATLAS 95

- Key
- 1 = Thermohydrometer
 - 2 = On switch
 - 3 = Manual-reset safety thermostat
 - 4 = 1st stage temperature adjustment knob
 - 5 = 2nd stage temperature adjustment knob

2.3 Turning on and off

Boiler lighting

Open the fuel shutoff valves.

Switch on the power to the unit.

Press button 2 of fig. 1 to feed the boiler and burner. Refer to the burner manual for operation.

Turning the boiler off

For brief shutdown periods just press button 2 of fig. 1 on the control panel, bringing it to position "0". For long shutdown periods, as well as operating button 2 also close the fuel shutoff valve. To avoid damage caused by freezing during long shutdowns in winter, add a suitable antifreeze to the system or completely drain the system.

2.4 Adjustments

Heating temperature setting

Set the required system temperature with the control thermostat 4 of fig. 1.

For the model **ATLAS 95**, with the control thermostat **5** then set the temperature of the 2nd stage to a temperature **10°C lower than that of the 1st stage**.

IMPORTANT: The temperature setting of the 2nd stage must always be lower than that of the 1st stage.

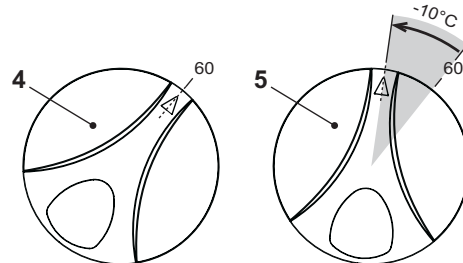

fig. 3 - Temperature adjustment for model ATLAS 95

Room temperature adjustment (with optional room thermostat)

Using the room thermostat, set the temperature desired in the rooms. If the room thermostat is not installed the boiler will keep the heating system at its setpoint temperature.

3. INSTALLATION

3.1 General Instructions

BOILER INSTALLATION MUST ONLY BE PERFORMED BY QUALIFIED PERSONNEL, IN ACCORDANCE WITH ALL THE INSTRUCTIONS GIVEN IN THIS TECHNICAL MANUAL, THE PROVISIONS OF CURRENT LAW, THE PRESCRIPTIONS OF NATIONAL AND LOCAL STANDARDS AND THE RULES OF PROPER WORKMANSHIP.

3.2 Place of installation

The boiler must be installed in a special room with ventilation openings towards the outside in conformity with current regulations. If there are several burners or extraction units that can work together in the same room, the ventilation openings must be sized for simultaneous operation of all the units. The place of installation must be free of flammable objects or materials, corrosive gases, volatile substances or dusts which, sucked by the burner fan, can obstruct the pipes inside the burner or the combustion head. The room must be dry and not exposed to rain, snow or frost.

If the unit is enclosed in a cabinet or mounted alongside, a space must be provided for removing the casing and for normal maintenance operations. In particular, after boiler installation with burner on the front door, make sure the front door can open freely without the burner striking walls or other obstacles.

3.3 Plumbing connections

The heating capacity of the unit must be previously established by calculating the building's heat requirement according to current regulations. The system must be provided with all the components for correct and regular operation. It is advisable to install shutoff valves between the boiler and heating system allowing the boiler to be isolated from the system if necessary.

! The safety valve outlet must be connected to a funnel or collection pipe to prevent water spurting onto the floor in case of overpressure in the heating circuit. Otherwise, if the discharge valve cuts in and floods the room, the boiler manufacturer cannot be held liable.

Do not use the water system pipes to earth electrical appliances.

Before installation, carefully wash all the pipes of the system to remove any residuals or impurities that could affect proper operation of the unit.

Carry out the relevant connections according to the diagram in and the cap. 5 symbols given on the unit.

! The unit is not supplied with an expansion tank; its connection must therefore be carried out by the installer. The pressure in the system, when cold, must be 1 bar.

Water system characteristics

In the presence of water harder than 25° Fr (1°F = 10ppm CaCO₃), use suitably treated water in order to avoid possible scaling in the boiler. Treatment must not reduce the hardness to values below 15°F (Decree 236/88 for uses of water intended for human consumption). Treatment of the water used is indispensable in case of very large systems or with frequent introduction of replenishing water in the system.

! If water softeners are installed at the boiler cold water inlet, make sure not to reduce the water hardness too much, as this could cause early deterioration of the magnesium anode in the hot water tank.

Antifreeze system, antifreeze fluids, additives and inhibitors

The boiler is equipped with an antifreeze system that turns on the boiler in heating mode when the system delivery water temperature falls under 6°C. The device will not come on if the electricity and/or gas supply to the unit are cut off. If it becomes necessary, it is permissible to use antifreeze fluid, additives and inhibitors only if the manufacturer of these fluids or additives guarantees they are suitable for this use and cause no damage to the heat exchanger or other components and/or materials of the boiler unit and system. It is prohibited to use generic antifreeze fluid, additives or inhibitors that are not expressly suited for use in heating systems and compatible with the materials of the boiler unit and system.

3.4 Burner connection

An oil or gas burner, with blown air for pressured furnaces, can be used if its operation characteristics are suitable for the size of the boiler furnace and its overpressure. The choice of burner must be made beforehand, following the manufacturer's instructions, according to the work range, fuel consumption and pressures, as well as the length of the firebox. Install the burner in compliance with the Manufacturer's instructions.

3.5 Electrical connections

Connection to the electrical grid



The unit's electrical safety is only guaranteed when correctly connected to an efficient earthing system executed according to current safety standards. Have the efficiency and suitability of the earthing system checked by professionally qualified personnel. The manufacturer is not responsible for any damage caused by failure to earth the system. Also make sure that the electrical system is adequate for the maximum power absorbed by the unit, as specified on the boiler dataplate.

The boiler is prewired and provided with a Y-cable and plug for connection to the electricity line. The connections to the grid must be made with a permanent connection and equipped with a bipolar switch whose contacts have a minimum opening of at least 3 mm, interposing fuses of max. 3A between the boiler and the line. It is important to respect the polarities (LINE: brown wire / NEUTRAL: blue wire / EARTH: yellow-green wire) in making connections to the electrical line. During installation or when changing the power cable, the earth wire must be left 2 cm longer than the others.



The user must never change the unit's power cable. If the cable gets damaged, switch off the unit and have it changed solely by professionally qualified personnel. If changing the electric power cable, use solely "HAR H05 VV-F" 3x0.75 mm2 cable with a maximum outside diameter of 8 mm.

Accessing the electrical terminal block

Undo the two screws "A" located on the top part of the control panel and remove the cover "B".

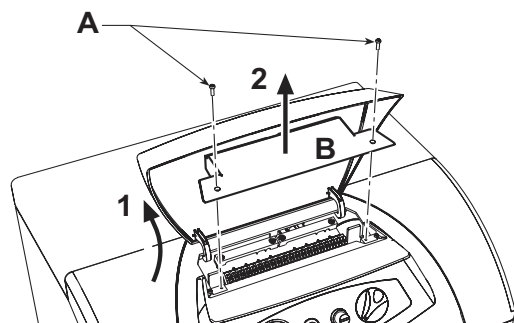

fig. 4 - Accessing the terminal block

3.6 Connection to the flue

The unit must be connected to a flue designed and built in compliance with current regulations. The pipe between the boiler and flue must be made from material suitable for the purpose, i.e. heat and corrosion resistant. Ensure the seal at the joints and insulate the entire pipe between boiler and flue, to prevent the formation of condensate.

4. SERVICE AND MAINTENANCE

All adjustment, conversion, start-up and maintenance operations described below must only be carried out by Qualified Personnel (meeting the professional technical requirements prescribed by current regulations) such as those of the Local After-Sales Technical Service.

FERROLI declines any liability for damage and/or injury caused by unqualified and unauthorised people tampering with the unit.

4.1 Adjustments

Burner adjustment

Boiler efficiency and correct operation depend above all on accurate burner adjustments. Carefully follow the Manufacturer's instructions. The two-stage burners must have the first stage adjusted to a power level not below the boiler's rated min. power. The power of the second stage must not be higher than the boiler's rated max. power.

4.2 Start-up



Checks to be made at first lighting and after all maintenance operations that involved disconnecting from the systems or an operation on safety devices or parts of the boiler:

Before lighting the boiler

- Open any on-off valves between the boiler and the systems.
- Check the seal of the fuel system.
- Check correct prefilling of the expansion tank.
- Fill the water system and make sure that all air contained in the boiler and the system has been vented, by opening the air valve on the boiler and any air valves on the system.
- Make sure there are no water leaks in the system, domestic hot water circuits, connections or boiler.
- Check correct connection of the electrical system and efficiency of the earthing system
- Make sure there are no flammable liquids or materials in the immediate vicinity of the boiler

Checks during operation

- Light the unit on as described in sec. 2.3.
- Make sure the fuel circuit and water systems are tight.
- Check the efficiency of the flue and air/fume ducts while the boiler is working.
- Make sure the water is circulating properly between the boiler and the systems.
- Check proper lighting of the boiler by doing several tests, turning it on and off with the room thermostat or remote control.
- Make sure the fuel consumption indicated on the meter matches that given in the technical data table on sec. 5.3.
- Make sure the fumebox and burner door are tight.
- Make sure the burner works properly. This check must be made with the special instruments, following the manufacturer's instructions.

4.3 Maintenance

Periodical check

To ensure correct operation of the unit over time, have qualified personnel carry out a yearly check, providing for the following:

- The control and safety devices must function correctly.
- The fume evacuation circuit must be perfectly efficient.
- Make sure there are no obstructions or dents in the fuel supply and return pipes.
- Clean the filter of the fuel suction line.
- Measure the correct fuel consumption
- Clean the combustion head in the fuel outlet zone, on the swirl disc.
- Leave the burner on at max. for about ten minutes, then analyse the combustion, checking:
 - Correct setting of the elements specified in this manual.
 - Temperatures of fumes at the flue
 - CO₂ percentage content
- The air/fume terminal and ducts must be free of obstructions and leaks
- The burner and exchanger must be clean and free of deposits. For cleaning do not use chemical products or wire brushes.
- The fuel and water systems must be tight.
- The water pressure in the system when cold must be approx. 1 bar; otherwise bring it to that value.
- The circulating pump must not be blocked.
- The expansion tank (not supplied) must be filled.



The boiler casing, control panel and aesthetic parts can be cleaned with a soft damp cloth, if necessary soaked in soapy water. Do not use any abrasive detergents and solvents.

Boiler cleaning

1. Disconnect the power supply to the boiler.
2. Remove the front top and bottom panel.
3. Open the door by undoing the knobs.
4. Clean the inside of the boiler and the entire path of exhaust fumes, using a tube brush or compressed air.
5. Then close the door, securing it with the knob.

To clean the burner, refer to the Manufacturer's instructions.

4.4 Troubleshooting

Fault

Two shutdown conditions resettable by the user can occur :

- A** Burner shutdown signalled by the special indicator. Refer to the burner manual.
- B** Cutting in of the safety thermostat, which occurs when the boiler temperature reaches a value beyond which a dangerous condition may be created. To restore operation, unscrew cap 3 of fig. 1 and press the reset button below.

If the problem persists, request the assistance of Qualified Personnel or the After-Sales Centre.

In case of a fault and/or poor operation, deactivate the unit, do not try to fix the problem or directly carry out any operation. Contact authorised and professionally qualified personnel.

5. TECHNICAL DATA AND CHARACTERISTICS

5.1 Dimensions, connections and main components

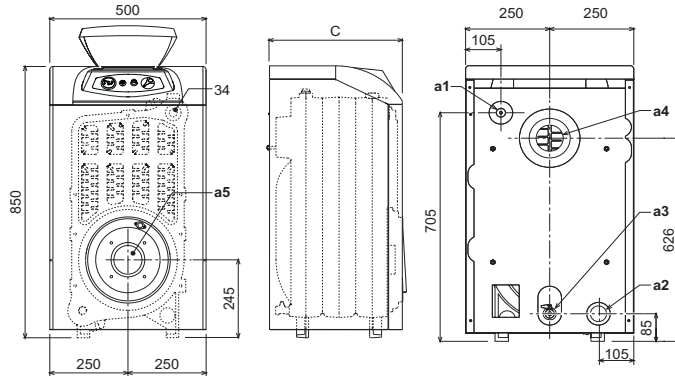

fig. 5 - Dimensions, connections and main components

Model	C mm	a4 Ø mm	a5 Ø mm
ATLAS 32	400	120+130	115
ATLAS 47	500	120+130	115
ATLAS 62	600	120+130	115
ATLAS 78	700	120+130	115
ATLAS 95	800	120+130	115

- a1 System delivery - 1" 1/2"
- a2 System return - 1" 1/2"
- a3 Heating system drain - 1/2"
- a4 Flue connection
- a5 Burner connection
- 34 Safety and heating temperature bulb

5.2 Pressure loss

Pressure loss water side

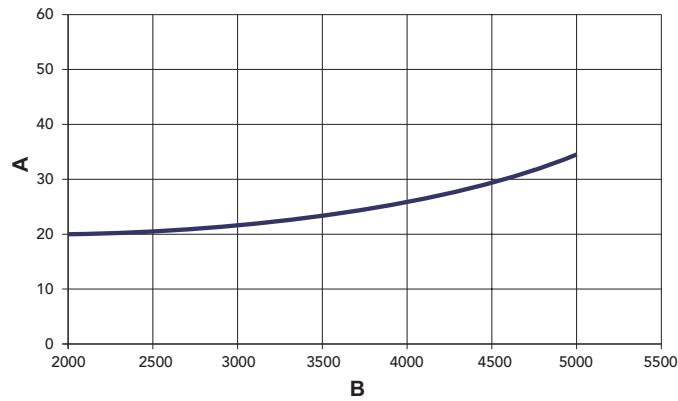

fig. 6 - Pressure loss

- A mbar
- B Flowrate l/h

5.3 Technical data table

Model		ATLAS 32	ATLAS 47	ATLAS 62	ATLAS 78	ATLAS 95	
Number of elements	no.	3	4	5	6	7	
Max. heating capacity	kW	34.9	51.6	67.7	85.6	103	(Q)
Min. heating capacity	kW	17.0	34.3	45.8	59.0	70.8	(Q)
Max. heat output in heating	kW	32	47	62	78	95	(P)
Min. heat output in heating	kW	16	32	43	55	66	(P)
Efficiency Pmax (80-60°C)	%	91.7	91.1	91.5	91.1	92	
Efficiency 30%	%	94.3	93.5	94.0	93.5	94.0	
Efficiency class Directive 92/42 EEC		★ ★					
Max. working pressure in heating	bar	6	6	6	6	6	(PMS)
Min. working pressure in heating	bar	0.8	0.8	0.8	0.8	0.8	
Max. heating temperature	°C	95	95	95	95	95	(tmax)
Heating water content	litres	18	23	28	33	38	
Protection rating	IP	X0D	X0D	X0D	X0D	X0D	
Power supply voltage	V/Hz	230/50	230/50	230/50	230/50	230/50	
Empty weight	kg	127	166	205	244	283	
Combustion chamber length	mm	350	450	550	650	750	
Combustion chamber diameter	mm	300	300	300	300	300	
Pressure loss fume side	mbar	0.27	0.3	0.45	0.4	0.63	

5.4 Wiring diagram

Main wiring diagram ATLAS 32-78

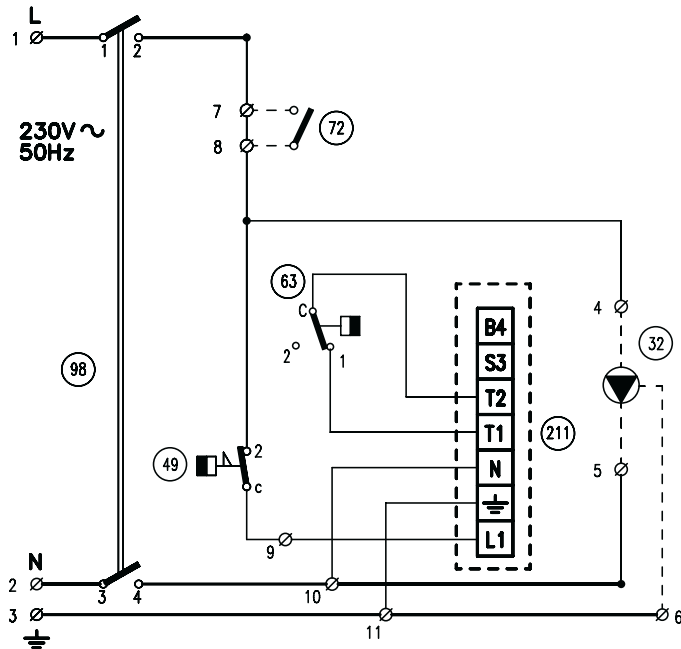

fig. 7 - Main wiring diagram ATLAS 32-78

Key fig. 7 and fig. 8

- 32 Heating circulating pump (not supplied)
- 49 Safety thermostat
- 72 Room thermostat (not supplied)
- 63 Boiler control thermostat
- 98 Switch
- 211 Burner connector (not supplied)

Electrical connection diagram ATLAS 32-78

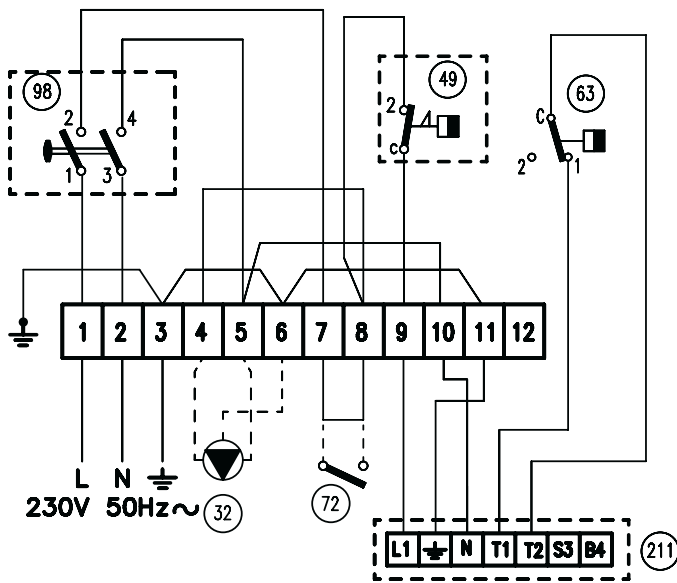

fig. 8 - Electrical connection diagram ATLAS 32-78

Main wiring diagram ATLAS 95

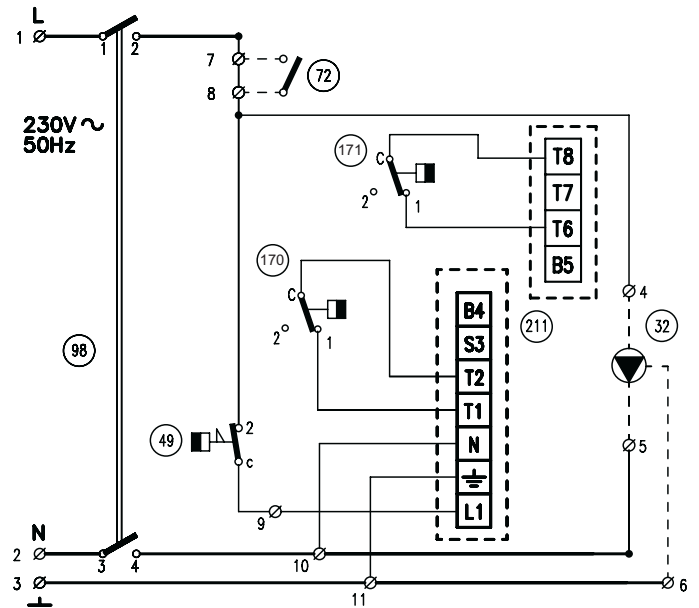

fig. 9 - Main wiring diagram ATLAS 95

Key fig. 9 and fig. 10

- 32 Heating circulating pump (not supplied)
- 49 Safety thermostat
- 72 Room thermostat (not supplied)
- 98 Switch
- 170 1st Stage boiler control thermostat
- 171 2nd Stage boiler control thermostat
- 211 Burner connector (not supplied)

Electrical connection diagram ATLAS 95

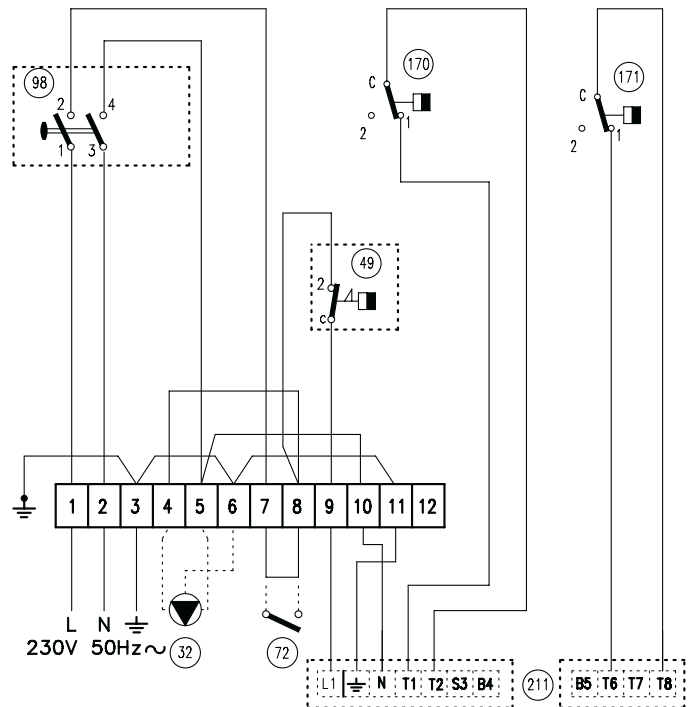

fig. 10 - Electrical connection diagram ATLAS 95



Operator Manual

Cummins **Onan**

Performance you rely on.™



Commercial Mobile Generator Set

HDKBB (Spec A–F)

HDKBC (Spec D–F)

California

Proposition 65 Warning

Diesel engine exhaust and some of its constituents are known to the State of California to cause cancer, birth defects, and other reproductive harm.



WARNING



Do not use this genset on a boat
Such use may violate U. S. Coast Guard
regulations and can result in
severe personal injury or death from
fire, electrocution, or
carbon monoxide poisoning



Table of Contents

SAFETY PRECAUTIONS	1
1.INTRODUCTION	8
About this Manual	8
Model Identification	8
noise	9
Electromagnetic compatibility	9
Engine Emissions Compliance	9
Fuel Recommendations	9
Engine Oil Recommendations	9
Starting Batteries	10
Typical Genset	10
Operator Console	11
Remote Control Panel	11
Build Standards	12
2.OPERATION	14
Pre-Start Checks	14
Priming the Fuel System	14
Starting the Genset	14
Stopping the Genset	14
Automatic Starting and Stopping	15
Loading the Genset	15
Connecting to Utility Power	15
Resetting Circuit Breakers	16
Operating in Cold Weather	17
Operating in Hot Weather	17
Operating at High Altitude	17
Operating in Dusty Environments	17
Breaking in a New Engine	17
Exercising the Genset	17
Storing the Genset	18
3.PERIODIC MAINTENANCE	20

Conducting General Inspections	21
Checking Engine Oil Level	22
Changing Engine Oil and Filter	23
Maintaining Battery and Battery Connections	24
Replacing Air Filter Element	24
Replacing Fuel Filter	25
Changing Coolant	27
4.TROUBLESHOOTING	30
5.SPECIFICATIONS	38
6.HOW TO OBTAIN SERVICE	40
7.MAINTENANCE RECORD	42



SAFETY PRECAUTIONS

Thoroughly read the OPERATOR'S MANUAL before operating the genset. Safe operation and top performance can only be obtained when equipment is properly operated and maintained.

Only trained and experienced service personnel with knowledge of fuels, electricity, and machinery hazards shall remove, dismantle and dispose of the generator set. See service manual.

Some generator set installation procedures present hazards that can result in severe personal injury or death. Only trained and experienced personnel with knowledge of fuels, electricity, and machinery hazards should perform generator set installation procedures

The following symbols in this manual alert you to potential hazards to the operator, service person and equipment.

⚠ DANGER Used to alert you to a lethal hazard against which you must take steps to prevent severe personal injury or death, as when you are in the vicinity of High Voltage equipment.

⚠ WARNING Used to alert you to a hazard or unsafe practice that can result in severe personal injury or death.

⚠ CAUTION Used to alert you to a hazard or unsafe practice that can result in personal injury or equipment damage.

Electricity, fuel, exhaust, moving parts and batteries present hazards which can result in severe personal injury or death.

ENGINE EXHAUST IS DEADLY

- Inspect for exhaust leaks at every startup and after every eight hours of running.
- Learn the symptoms of carbon monoxide poisoning in the genset Operator's Manual.
- Never sleep in the vehicle while the genset is running unless the vehicle is equipped with a working carbon monoxide detector.
- Do not operate the genset when the vehicle is parked in a confined space, such as a garage.
- Disable the automatic genset starting feature (AGS) of an inverter-charger or other automatic

starting device before storing the vehicle or parking it in a garage or other confined space.

- The exhaust system must be installed in accordance with the genset Installation Manual.
- Engine cooling air must not be used for heating the vehicle.

GENERATOR VOLTAGE IS DEADLY

- Disable the automatic genset starting feature (AGS) of an inverter-charger or other automatic starting device before servicing the genset.
- Generator electrical output connections must be made by a trained and experienced electrician in accordance with applicable codes.

⚠ WARNING *Interconnecting the generator set and shore power can lead to electrocution or utility line workers, equipment damage and fire. Use an approved switching device to prevent interconnections.*

- Use caution when working on live electrical equipment. Remove jewelry, make sure clothing and shoes are dry, stand on a dry wooden platform or rubber insulating mat and use tools with insulated handles.

DIESEL FUEL IS COMBUSTIBLE

- Do not smoke or turn electrical switches ON or OFF where fuel fumes are present or in areas sharing ventilation with fuel tanks or equipment. Keep flames, sparks, pilot lights, arc-producing equipment and all other sources of ignition well away.
- Fuel lines must be secured, free of leaks and separated or shielded from electrical wiring.

MOVING PARTS CAN CAUSE SEVERE PERSONAL INJURY OR DEATH

- Disable the automatic genset starting feature (AGS) of an inverter-charger or other automatic starting device before servicing the genset.
- Do not wear loose clothing or jewelry near moving parts such as PTO shafts, fans, belts and pulleys.
- Keep hands away from moving parts.
- Keep guards in place over fans, belts, pulleys, and other moving parts.

BATTERY GAS IS EXPLOSIVE

- Wear splash-proof safety glasses.
- Do not smoke or permit flames or sparks to occur near the battery at any time.
- To reduce arcing when disconnecting or reconnecting battery cables, always disconnect the negative (-) battery cable first and reconnect it last.

FLAMMABLE VAPOR CAN CAUSE A DIESEL ENGINE TO OVERSPEED

⚠WARNING *Do not operate a diesel-powered genset where a flammable vapor environment can be created by fuel spill, leak, etc.*

Flammable vapor can cause a diesel engine to overspeed and become difficult to stop, resulting in possible fire, explosion, severe personal injury and death. The owners and operators of the genset are solely responsible for operating the genset safely.

GENERAL PRECAUTIONS

- Keep children away from the genset.
- Do not use evaporative starting fluids. They are highly explosive.
- To prevent accidental or remote starting while working on the genset, disconnect the negative (-) battery cable at the battery.
- Keep the genset and its compartment clean. Excess oil and oily rags can catch fire. Dirt and gear stowed in the compartment can restrict cooling air.
- Make sure all fasteners are secure and torqued properly.
- Do not work on the genset when mentally or physically fatigued or after consuming alcohol or drugs.
- Used engine oil has been identified by some U. S. state and federal agencies as causing cancer or reproductive toxicity. Do not ingest, inhale, or contact used oil or its vapors.

- Ethylene glycol, used as engine antifreeze, is toxic to humans and animals. Clean up spills and dispose of used engine coolant in accordance with local environmental regulations.
- Keep multi-purpose fire extinguishers handy. Multi-purpose fire extinguishers are used for fires that involve ordinary combustible materials such as wood and cloth; combustible and flammable liquid fuel and gaseous fuels; live electrical equipment. (North America or US: ref. NFPA No. 10)
- Genset installation and operation must comply with all applicable local, state and federal codes and regulations.
- Generator sets with a sound shield shall not be run with the service doors remove/missing.
- Engine components can be hot and cause severe burns. Hot coolant under pressure can spray and cause severe burns.
- Use personal protective equipment when performing periodic maintenance operations such as gloves, safety glasses, etc.

THE HAZARDS OF CARBON MONOXIDE

⚠WARNING *Engine-driven generators can produce harmful level of carbon monoxide that can injure or kill you.*

ONLY YOU CAN PROTECT YOURSELF FROM CO POISONING!

- Watch constantly for people near the exhaust of the generator set while it is running.
- Make sure exhaust cannot enter the living quarters through a window, vent or door.
- Make sure all CO detectors or audible alarms are working properly.
- Pay attention to the signs of CO poisoning.
- Check the exhaust system for corrosion, obstruction and leaks each time you start the generator set and every eight hours if you run it continuously.

SUBSTANCE HAZARDOUS TO HEALTH

Generator sets use substances, and emit and create wastes that can cause health risks. Generator set operators must use appropriate personal protective equipment (such as clothing, gloves, protective glasses/goggles, and respiration equipment) when exposed to fuel, oil, coolant, wet batteries, grease, cleaning agents, or other substances exposed to lungs, eyes, or skin. Use appropriate containers for transport, storage, and disposal of waste substances. Follow local regulations for disposal and recycling.

ANTIFREEZE (FLEETGUARD – ES COMPLEAT/EG PREMIX)

This antifreeze is also known as an ethylene glycol based coolant; summer coolant; coolant additive. It is purple coloured, viscous liquid, with a mild chemical odour, is soluble in water and harmful. It contains ethylene glycol, and diethylene glycol. Ethylene glycol is a potentially hazardous constituent.

The substance has a boiling point of 107° C, and a flash point of 121° C.

It is used as an engine coolant additive, and can be found in engine cooling systems, and head exchangers. Installers, operators and maintainers are likely to encounter this substance.

HAZARDOUS REACTIONS

Ethylene glycol is combustible when exposed to heat or flame and can react vigorously with oxidants. Moderate explosive hazard in form of vapour when exposed to heat or flame. Hazardous products resulting from combustion or decomposition include carbon monoxide, carbon dioxide and acrid smoke. Self-contained breathing apparatus must be worn in the event of fume build up.

Avoid strong oxidizing agents – incompatible with sulfuric acid, nitric acid, caustics and aliphatic amines.

It may cause neurological signs and symptoms, and kidney damage. It is also a skin and eye irritant.

Very toxic in particulate form upon inhalation. Harmful if swallowed, lethal dose for humans reported to be 100ml.

PROTECTIVE MEASURES

Refrain from eating, drinking or smoking when using the product. Adopt a high standard of personal hygiene. In case of skin contact, wash immediately with soap and water.

Ensure good ventilation and avoid heat sources. Avoid breathing mist, if there is a risk of vapour, or particulate, use a suitable organic vapour mask.

Eye protection, gloves, overalls, impervious apron should be used. Avoid contamination inside the gloves. If overalls become contaminated, discontinue use and clean thoroughly.

STORAGE/TRANSPORT

Store and transport only in correctly marked containers. Keep containers closed when not in use. Keep cool, out of sunlight, away from naked flames and strong acids, do not freeze. Store well away from food-stuffs and drinking water. Take special care to avoid discharge into drains, sewers and water-courses.

Contain leak/spill with sand, earth or non-combustible, absorbent material to prevent entry of substance into drainage/sewerage system, water-courses and land. Eliminate all ignition sources, use plastic shovel to transfer to suitable container and dispose of unwanted or absorbed substance through authorized contractor to a licensed site.

EMERGENCY ACTION

- Fire
Extinguishing media: CO₂, alcohol resistant foam, dry powder, or water spray.
Fire fighters to use self contained breathing apparatus. Keep fire exposed containers cool. Prevent run-off from entering waterways, drains and drinking water supplies.
- Ingestion
Toxic by ingestion. If swallowed induce vomiting only under the advice of a Doctor or poison control centre. Delayed treatment may result in fatality.
- Inhalation (of vapour)
Remove from further exposure. In case of irritation to lungs or throat, seek medical advice.
- Aspiration (inhalation of liquid)
Obtain immediate medical assistance.
- Eyes
Flush copiously with water or preferably eye-

wash solution for at least five minutes. Seek medical advice.

- Skin
Wash thoroughly with soap and water, and seek medical attention if irritation develops. Change clothing if necessary and wash before re-use.
- Spillage
Soak-up using an absorbent material and dispose of this as directed under Storage/Transport (Section 5.1.3)

GAS OIL

This product is also known as Red Diesel, Fuel Oil, and type A1 or A2. It can be pale red or a clear liquid with a characteristic mild odour. It contains catalytically cracked oil, petroleum distillates, quinizarin, and gas oil maker dye red. The catalytically cracked oil and petroleum distillates are potentially hazardous constituents.

The substance has an initial boiling point of 180°C, a flash point greater than 56°C, and a vapour pressure less than 0.7mm Hg at 20°C and has negligible solubility in water.

It is used as a fuel for off-road diesel powered vehicles and stationary engines, and can be found in fuel tanks, pipes and injection systems. The substance should not be used for any other purpose without contacting the manufacturer or supplier. Installers, operators and maintainers are likely to encounter this substance.

HAZARDOUS REACTIONS

This liquid is flammable. Avoid smoking, heat sources, such as welding and naked flames, sparks and static electricity build-up. Thermal decomposition products are hazardous, containing CO_x, NO_x and SO_x compounds.

The vapour is explosive. High vapour concentrations can cause respiratory irritation, dizziness, nausea, and loss of consciousness. Excessive and prolonged exposure to the mist can cause chronic inflammatory reaction of the lungs and form of pulmonary fibrosis.

Avoid strong oxidising agents, e.g. chlorates which may be use in agriculture.

Gas oil is slightly irritating to the skin and has a de-fatting action. Toxicity following single exposure to high level of gas oil is of low order. Prolonged, repeated skin contact may de-fat the skin resulting in possible skin irritation and dermatitis. In some cases warty, cancerous growths have occurred.

PROTECTIVE MEASURES

Ensure good ventilation and avoid heat sources. Observance of good housekeeping rules will ensure general safety. Do not smoke. Avoid breathing mist.

When working on, or testing, injection equipment, special care is required to avoid perforation of skin by high pressure fuel. Use eye protection in the event of suspected high pressure leak.

Adopt a high standard of personal hygiene. In the case of skin contact, wash well with soap and water.

Use glove and overalls, and eye protection goggles if there is a risk of splashing. Use oil impervious gloves and avoid contamination inside the gloves. If overalls become contaminated, discontinue use and clean thoroughly. Contaminated clothing should be removed, soaked with water, and laundered before re-use.

No special respiratory precautions are necessary in normal use.

DO NOT use as a solvent for removing dirt/grease etc, from skin.

STORAGE/TRANSPORT

Store and transport only in correctly marked containers. Keep containers closed when not in use. Keep cool, out of sunlight and away from naked flames. Electrical continuity is required between the transport and storage vessels during product transfer.

Contain leak/spill with sand, earth or other suitable material, and prevent entry of substance into drainage/sewerage system, water-courses and land. Dispose of unwanted or absorbed substance through an authorized contractor to a licensed site.

Inform local and fire authorities should the product reach waterways, drains etc.

EMERGENCY ACTION

- Fire
Extinguishing media:
Large fire – Foam/water fog. Never use water jet.
Small fire – foam/dry powder, AAAF, CO₂, sand, earth.
Avoid making sparks. Fire fighters to use self-contained breathing apparatus. Keep fire exposed containers cool, using water fog/spray. Prevent run-off from entering waterway, drains and drinking water supplies.
- Ingestion
Do not induce vomiting. Wash the mouth out with water, and send to hospital immediately.
- Inhalation (of vapour)
Remove from further exposure. Obtain medical assistance immediately.
- Aspiration (inhalation of liquid)
If, following ingestion of gas oil, vomiting occurs, there is danger of aspiration into the lungs. This would cause intense local irritation and chemical pneumonitis that can be fatal. Obtain immediate medical assistance.
- Eyes
Irrigate copiously with water or preferably eye-wash solution for at least five minutes. If irritation persists seek medical advice.
- Skin
Wash thoroughly with soap and water. Change clothing if necessary.
If high pressure injection has occurred prompt surgical attention is required.
- Spillage
Absorb using sand, earth or other suitable material. Dispose of unwanted or absorbed flammable material as directed under Storage/Transport (Section 5.7.3).

LUBRICATION OIL – PREMIUM BLUE E 15W40

Also known as oil, lube oil, sump oil, new oil is dark, viscous liquid with a slight, characteristic odour. The base oil contains: distillates (petroleum), solvent-dewaxed heavy paraffinic. It is not classified as dangerous according to Directive 1999/45/EC and its amendments, and is not classified according to the EU regulations.

It has a boiling point greater than 150°C, a flash point Open Cup of 220°C (Cleveland), and is insoluble in cold water.

It is used in engine lubricant oil systems, sump pan and filters, make-up tanks and piping systems as a lubrication oil for use in wide range of diesel engines operating under severe conditions. Installers, operators and maintainers are likely to encounter this product.

HAZARDOUS REACTIONS

This product is stable although slightly re-active with oxidising agents. Results of decomposition are carbon oxides (CO, CO₂) and water.

Although harmful if swallowed or aspirated (breathed in), repeated or prolonged exposure is not known to aggravate medical conditions.

Used oil may contain harmful combustion by-products and unburnt fuel that will cause skin reactions as detailed for fuel. Particular care must be taken if oil from a severely overheated engine is handled – use impervious gloves, lab coat and safety glasses.

Do not breathe vapour/spray.

PROTECTIVE MEASURES

Ensure good ventilation and avoid heat sources.

Adopt a high standard of personal hygiene. In case of skin contact, wash thoroughly with soap and water.

Use safety glasses, impervious gloves and lab coat. Avoid contamination inside the gloves. If overalls become contaminated, discontinue use and clean thoroughly.

No special respiratory precautions are necessary in normal use. Do not breathe vapour/spray when handling hot materials.

STORAGE/TRANSPORT

Store and transport only in correctly marked containers. Keep containers tightly sealed when not in use. Keep in a cool, well ventilated area, out of sunlight and away from naked flames. Store well away from food-stuffs and drinking water.

Wear splash goggles, full suit, boots and gloves. Absorb leak/spill with an inert material and dispose of unwanted or absorbed substance through an authorized contractor to a licensed site. Finish cleaning by spreading water on the contaminated surface and allow to evacuate through the sanitary system.







EMERGENCY ACTION

- Fire
Extinguishing media:
Large fire – Use water spray, fog or foam. Do not use water jet.
Small fire – Use dry chemical powder or CO₂
Fire-fighters to use self contained breathing apparatus and full turnout gear. Keep fire exposed containers cool.
- Ingestion
Do not induce vomiting, Obtain medical advice immediately.
- Inhalation (of vapour)
Remove from further exposure. Obtain medical attention.
- Aspiration (inhalation of liquid)
Obtain immediate medical assistance.
- Eyes
Flush copiously with water or preferably eye-wash solution for at least fifteen minutes. Obtain medical advice.
- Skin
Wash thoroughly with soap and water. Obtain medical advice if irritation develops. Change clothing if necessary and wash before re-use.
- Spillage
Absorb with an inert material and dispose of this as directed under Storage/Transport.



Generator Set Warning Labels

Warning signs are provided on the generator set at or near the point of risk. To avoid injury, always take the necessary precautions – as indicated on the sample signs shown below:

	Caution / Warning. Indicates a risk of personal injury.
	Caution / Warning of Temperature Hazard. Indicates a risk of personal injury from high temperature.
	Caution / Warning of High Voltage Hazard. Indicates a risk of personal injury from electric shock/electrocution.
	Caution / Warning. Indicates a risk of personal injury from equipment that may be subject to automatic starting or remote starting.
	Caution / Warning. Indicates to read Operator manual for additional information.
	Caution / Warning of Belt and Rotating Part Hazard. Indicates a risk of personal injury from entanglement in moving parts.
	Caution / Warning of Pressure Hazard. Indicates a risk of personal injury from pressurized fluids.

1.Introduction

ABOUT THIS MANUAL

This is the Operator Manual for the generator sets (gensets) listed on the front cover. Read and carefully observe all of the instructions and precautions in this manual. Keep this manual with the other vehicle manuals.

Operation, Periodic Maintenance and Troubleshooting provide the instructions necessary for operating the genset and maintaining it at top performance. The owner is responsible for performing maintenance in accordance with the PERIODIC MAINTENANCE SCHEDULE (Page 20).

⚠WARNING *This genset is not a life support system. It can stop without warning. Children, persons with physical or mental limitations, and pets could suffer personal injury or death. A personal attendant, redundant power or an alarm system must be used if genset operation is critical.*

⚠WARNING *This generator set is not “ignition protected” and shall not be used in a flammable vapor environment.*

⚠WARNING *Improper service or replacement of parts can lead to severe personal injury or death and to damage to equipment and property. Service personnel must be qualified to perform electrical and mechanical service.*

Unauthorized modifications or replacement of fuel, exhaust, air intake or speed control system components that affect engine emissions are prohibited by law in the State of California.

MODEL IDENTIFICATION

Be ready to provide the genset model and serial numbers on the nameplate when contacting Cummins Onan for parts, service or information. Figure 1 illustrates the nameplate and its location. The gray boxes illustrate where to look for the model and serial numbers.

Record these numbers in the figure that they are easy to find when needed. Each character in these numbers is significant. The last character of the model number is the specification letter, which is important for obtaining the right parts. Genuine Cummins Onan

replacement parts are recommended for best results. Refer to the genset Parts Catalog.

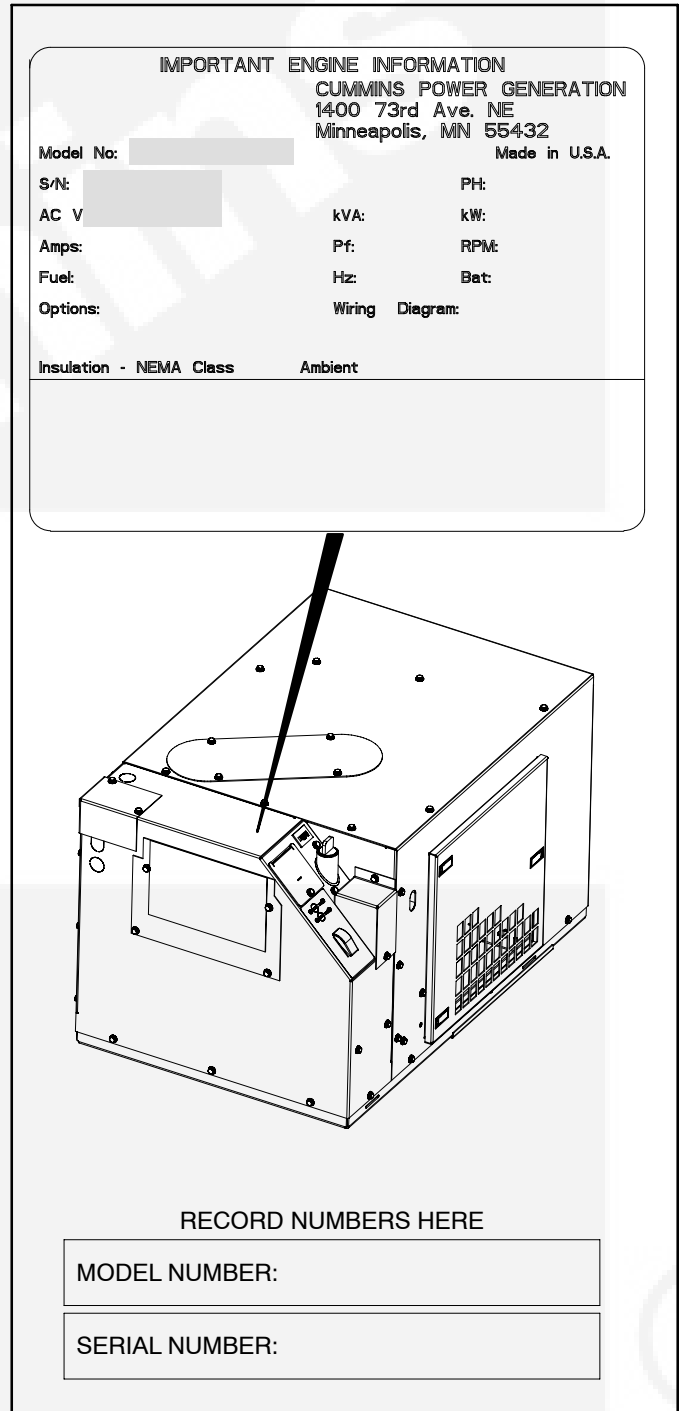

FIGURE 1. TYPICAL NAMEPLATE

NOISE

Generator sets emit noise. As noise level and time of exposure increase, risk of hearing damage increases. The Specifications page in the Operator manual states noise level for this generator set. Select and use personal hearing protection appropriate for your exposure to generator set noise.

Note for use in countries where compliance to the EU Noise directive is required: This generator set has not been evaluated and is not marked for use in open air. Install the generator set in accordance with the Installation manual. Obey local noise restrictions when you operate the generator set.

ELECTROMAGNETIC COMPATIBILITY

Generator sets emit and receive electromagnetic (radio frequency) energy. If the generator set affects operation of nearby devices, or nearby devices affect generator set operation, increase the distance between them.

Note for use in countries where compliance to the EMC directive is required: This generator set has been evaluated for use in residential, commercial, and light industrial environments.

ENGINE EMISSIONS COMPLIANCE

Labels that state compliance with applicable engine emissions regulations are located on the side of the engine valve cover and in the lower left hand corner on the front of the genset. Refer also to the FEDERAL EMISSION DESIGN AND DEFECT LIMITED WARRANTY FOR C. I. ENGINES (DIESELS) that was shipped in the same package as the Operator Manual.

FUEL RECOMMENDATIONS

⚠WARNING *Diesel fuel is combustible and can cause severe personal injury or death. Do not smoke near fuel tanks or fuel-burning equipment or in areas sharing ventilation with such equipment. Keep flames, sparks, pilot flames, electrical arcs and switches and all other sources of ignition well away. Keep a multi-class ABC fire extinguisher handy.*

High quality diesel fuel is necessary for good performance and long engine life.

- The specifications for the type and sulfur content (ppm, % weight) of the diesel fuel used must

comply with all emissions regulations applicable in the areas where the genset is to be operated.

- Diesel fuels meeting ASTM D975 or EN 590 specifications are recommended. Use Grade 1-D diesel fuel where ambient temperatures are below 14° F (–10° C). A minimum Fuel Cetane Rating of 45 is recommended. Where ambient temperatures are below –4 F (–20° C), or the elevation is above 5000 ft (1500 m), a minimum Cetane Rating of 50 is recommended.
- Current US EPA regulations for Non-Road engines limit diesel fuel sulfur content to a maximum of 500 ppm (0.05% weight). Therefore, use Grade 2-D S500 or 2-D S15 diesel fuel. Where ambient temperatures are below 14° F (–10° C), use Grade 1-D S500 or 1-D S15 diesel fuel. Note that beginning in year 2010, US EPA regulations for Non-Road engines will limit diesel fuel sulfur content to a maximum of 15 ppm (0.0015% weight).
- Do not use diesel fuel having a sulfur content greater than 10,000 ppm (1.0% weight).
- Diesel fuel must meet the ASTM D975 standard for lubricity and pass a minimum load level of 3100 grams as measured by ASTM D6078, or maximum scar diameter of 0.45 mm as measured by ASTM D6079 or ISO 12156–1.
- B5 Bio-Diesel fuel that meets industry specifications and quality is suitable for use with this genset.

ENGINE OIL RECOMMENDATIONS

Oil Performance Class

Use API (American Petroleum Institute) classified engine oils according to the following guidelines:

- **Emissions-Regulated Areas:** It is mandatory to use CF, CF–4, CG–4, CH–4 or CI–4 class oil with low sulfur fuel (sulfur content less than 500 ppm, 0.05% weight) or ultra low sulfur fuel (sulfur content less than 15 ppm, 0.0015% weight).
- **Non-Regulated Areas:** CF class oil is recommended when using high sulfur fuel—sulfur content between 500 ppm (0.05% weight) and 5000 ppm (0.5% weight). If CF–4, CG–4, CH–4 or CI–4 class oil is used, the oil and oil filter must be changed twice as often as specified in the PERIODIC MAINTENANCE SCHEDULE (Page 20).

- **Non-Regulated Areas:** Use CF, CF-4, CG-4, CH-4 or CI-4 class oil when using high sulfur fuel—sulfur content between 5000 ppm (0.5% weight) and 10,000 ppm (1.0% weight). The oil and oil filter must be changed twice as often as specified in the PERIODIC MAINTENANCE SCHEDULE (Page 20).

Oil Viscosity

Look for the SAE (Society of Automotive Engineers) viscosity grade. Referring to Figure 2, choose the viscosity grade appropriate for the ambient temperatures expected until the next scheduled oil change. Multi-grade oils such as SAE 15W-40 are recommended for year-round use.

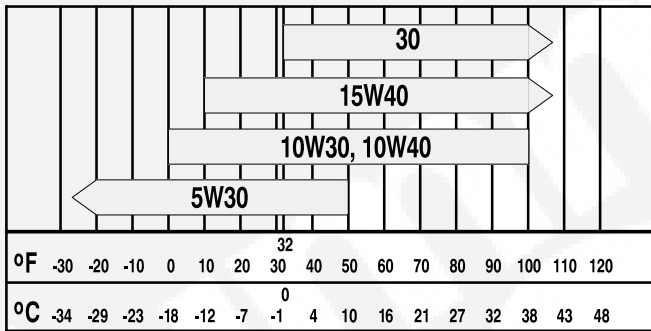

FIGURE 2. OIL VISCOSITY VS. TEMPERATURE

STARTING BATTERIES

The genset requires a 12 volt battery to power its control and starting circuits. Reliable genset starting and starter service life depend upon adequate battery system capacity and maintenance. See *Specifications* (Page 38) for battery requirements and **MAINTAINING THE BATTERY AND BATTERY CONNECTIONS** (Page 24) for battery care.

TYPICAL GENSET

Figure 3 illustrates a typical genset.

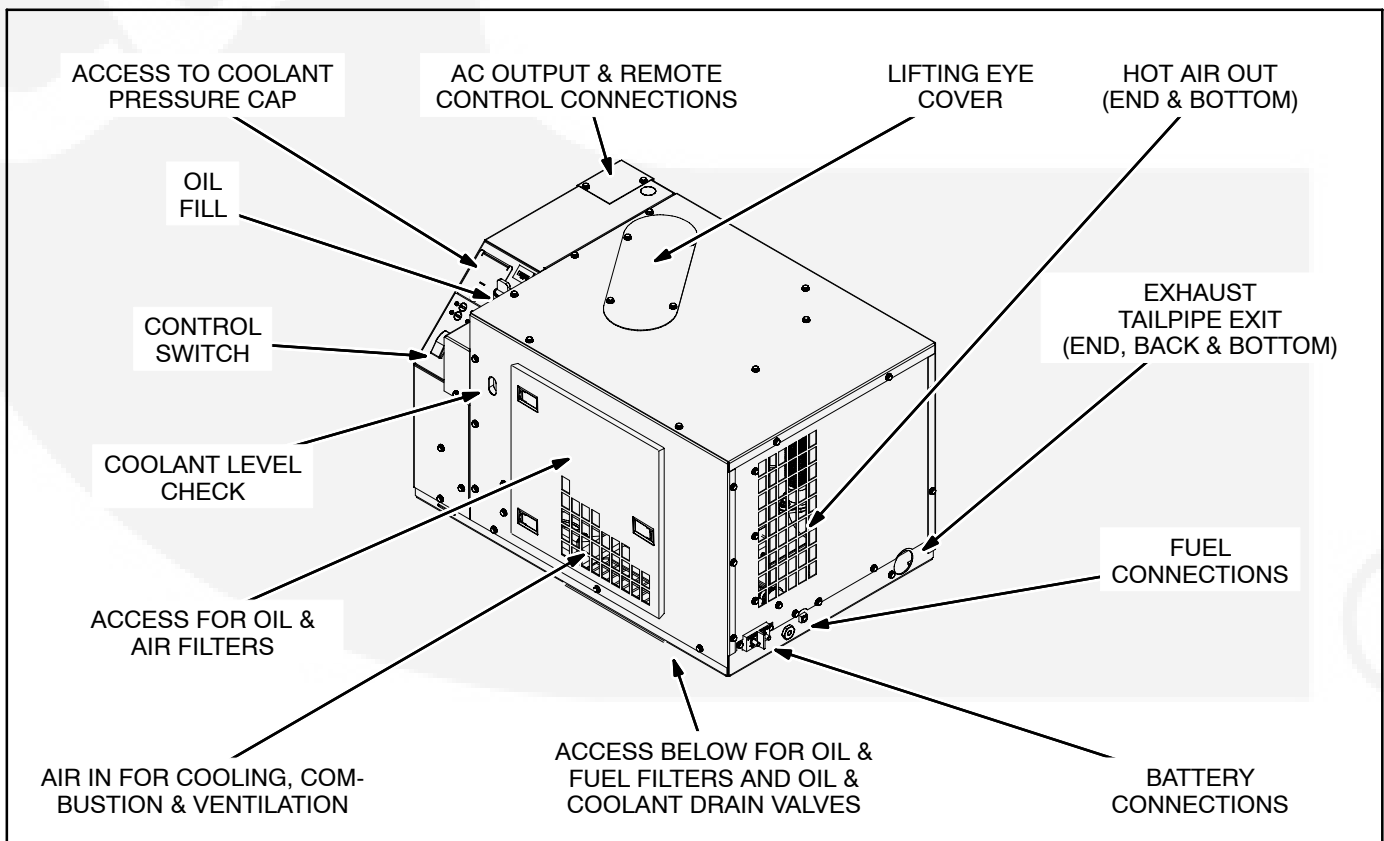

FIGURE 3. TYPICAL GENSET

OPERATOR CONSOLE

The console (Figure 4) has the following features:

Control Switch

This switch is used to start and stop the genset, prime the engine fuel system and restore the fault code (blinking status light).

Status Light

This is an LED (light emitting diode) in the control switch which blinks rapidly during preheat and cranking. After the genset starts up, this light stays on continuously, indicating that the genset is running and that the starter has disconnected. If the genset shuts down, this light blinks in coded fashion to indicate the nature of the fault shutdown (see *Troubleshooting*, Page 30).

(Rapid blinking before cranking starts indicates that the glow plugs are preheating the combustion chambers. The controller automatically varies the time based on engine temperature.)

Line Circuit Breakers

The line circuit breakers protect the AC power leads connected to the genset.

Coolant Pressure Cap

The coolant pressure cap is under the access plate. Fill coolant here when refilling the system.

Coolant Recovery Tank

The recovery tank is mounted inside the genset and provides for coolant expansion. The coolant level is visible through the sight hole on the front of the genset. The fill cap is under the access cover. Replenish the normal loss of coolant here.

Oil Fill Cap and Dipstick

Check and fill engine oil.

REMOTE CONTROL PANEL

The vehicle probably has a control panel inside the vehicle for remote control of the genset. Cummins Onan offers three remote control kits as follows:

- Remote switch / status lamp
- Remote switch / status lamp and hour meter
- Remote switch / status lamp and DC voltmeter

The DC voltmeter indicates whether voltage across the 12 VDC control system and battery is normal. If the indicator consistently stays above or below the normal zone, see **MAINTAINING THE BATTERY AND BATTERY CONNECTIONS** (Page 24).

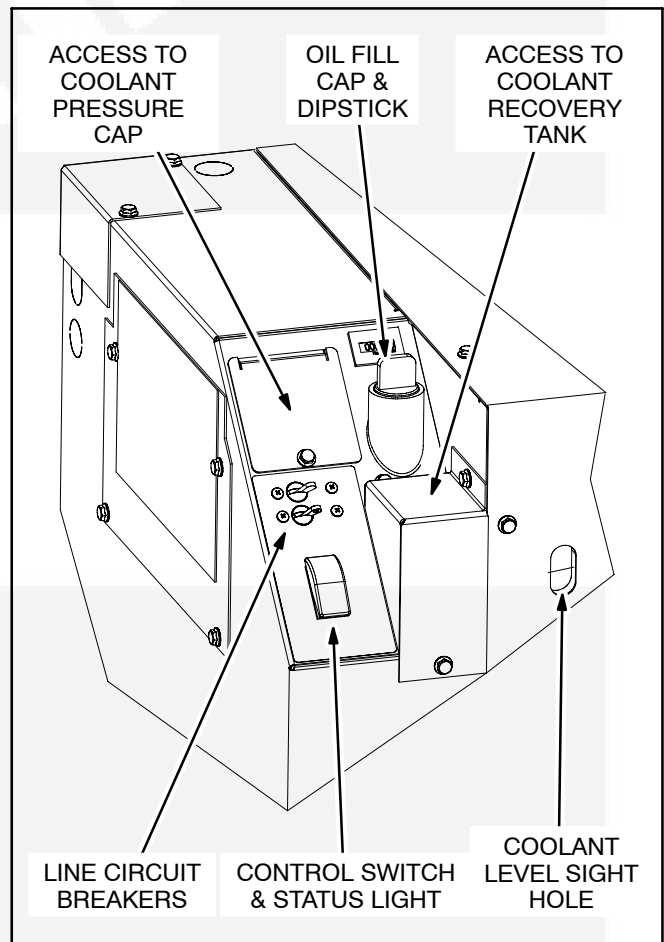

FIGURE 4. OPERATOR'S CONSOLE

BUILD STANDARDS

The generator set and its control system have been designed, constructed and tested generally in accordance with the following Standards where applicable refer to Table 1.

TABLE 1. BUILD STANDARDS

BS EN 1037:1995+A1:2008	Safety of machinery – Prevent of unexpected start up.
BS EN ISO 14121–1:2007	Safety of machinery. Risk assessment. Principles
BS EN ISO 13857:2008	Safety of machinery. Safety distance to prevent hazard zones being reached by upper and lower limbs.
BS EN 349:1993+a1:2008	Safety of machinery – Minimum gaps to avoid crushing parts on the human body.
BS EN 547–1: 1996+A1:2008	Safety of machinery – Human body dimensions – Part 1: Principles of determining the dimensions required for openings for whole body access into machinery.
BS EN 547–2:1996+A1:2008	Safety of machinery – Human body dimensions – Part 2: Principles for determining the dimensions required for access openings.
BS EN 547–3:1996+A1:2008	Safety of machinery – Human body dimensions – Part 3: Anthropomorphic data.
BS EN 60204–1:2006+A1:2009	Safety of machinery. Electrical equipment of machines. General requirements
BS EN 614–1:2006+A1:2009	Safety of machinery. Ergonomic design principles. Terminology and general principles
BS EN 953:1997+A1:2009	Safety of machinery – Guards – General requirements for the design and construction of fixed and movable guards.
BS EN ISO 12100–1:2003+A1:2009	Safety of machinery. Basic concepts, general principles for design. Basic terminology, methodology
BS EN ISO 12100–2:2003+A1:2009	Safety of machinery. Basic concepts, general principles for design. Technical principles
BS EN ISO 13732–1:2008	Ergonomics of the thermal environment. Methods for the assessment of human responses to contact with surfaces. Hot surfaces
BS EN ISO 13849–1:2008	Safety of machinery – Safety related parts of control systems
BS EN ISO 13850:2006	Safety of machinery – Emergency stop. Principles for design.
BS EN 61310–1:2008	Safety of machinery – Indication, marking and actuation – Part 1: Requirements for visual, auditory and tactile signals.
BS EN 61310–2:2008	Safety of machinery – Indication, marking and actuation – Part 2: Requirements for marking.
BS EN 61000–6–1:2007	Electromagnetic compatibility (EMC). Generic standards. Immunity standard for residential, commercial and light–industrial environments

BS EN 61000-6-3:2007	Electromagnetic compatibility (EMC). Generic standards. Emission standard for residential, commercial and light-industrial environments
BS EN 1299:1997+A1:2008	Mechanical vibration and shock – Vibration isolation of machines – Information for the application of source isolation
BS EN 1679-1:1998	Reciprocating internal combustion engines – Safety – Part 1: Compression ignition engines
BS EN 12601:2001	Reciprocating internal combustion engine driven generating sets – Safety



2. Operation

⚠WARNING *EXHAUST GAS IS DEADLY! All engine exhaust contains carbon monoxide; an odorless, colorless, poisonous gas that can cause unconsciousness and death. Symptoms of carbon monoxide poisoning include:*

- *Dizziness, Headache or Throbbing Temples*
- *Weakness or Muscular Twitching*
- *Sleepiness or Confusion*
- *Nausea or Vomiting*

⚠WARNING *IF YOU EXPERIENCE ANY OF THESE SYMPTOMS, GET INTO FRESH AIR IMMEDIATELY. If symptoms persist, seek medical attention. Shut down the genset and do not operate it until it has been inspected and repaired.*

⚠WARNING *Never sleep in the vehicle while the genset is running unless the vehicle has a working carbon monoxide detector. The exhaust system must be installed in accordance with the genset Installation Manual. Make sure there is ample fresh air when operating the genset in a confined area.*

PRE-START CHECKS

Before the first start of the day and after every eight hours of operation, inspect the genset as instructed under CONDUCTING GENERAL INSPECTIONS (Page 14). Keep a log of maintenance and the hours run and perform any maintenance that may be due. See Returning the Genset to Service (Page 18) if the vehicle has been in storage.

Before each start:

1. Make sure all vehicle CO detectors are working.
2. Check for signs of fuel and exhaust leaks and damage to the exhaust system.
3. To prevent overheating and to reduce fouling with dust and debris, make sure the genset's normal ground clearance is not being reduced by sloping ground, curbs, logs or other objects. Re-

park the vehicle if necessary and/or remove any objects blocking the air inlet or air outlet.

4. Turn off air conditioners and other large equipment.

PRIMING THE FUEL SYSTEM

The fuel system should be primed after replacing the fuel filter or running the genset out of fuel. To prime the fuel system hold the control switch down in its **Stop** position for at least 1 minute (starts in 2 seconds).

STARTING THE GENSET

Start the genset from the genset control panel or remote control panel inside the vehicle.

⚠CAUTION *Excessive cranking can overheat and damage the starter motor. Do not crank for more than 30 seconds at a time. Wait at least 2 minutes before trying again.*

1. Visually inspect for fuel, exhaust and coolant leaks. Do not start the genset if there is a fuel, exhaust or coolant leak and have it repaired.
2. Push and hold the switch at **START** until the genset starts. The status indicator light on the switch flashes during preheat and cranking. It will come on solid when the starter disconnects, indicating that the genset is running. (Depending on how cold it is, preheat can take up to 15 seconds, extending the time that the light blinks.)
3. See *Troubleshooting* (Page 30) if the genset does not start after several tries.
4. For top performance and engine life, especially in colder weather, let the engine warm up for two minutes before connecting loads.

STOPPING THE GENSET

Turn off air conditioners and other large loads and let the genset run for two minutes to cool down. Then push the switch to **STOP**.

AUTOMATIC STARTING AND STOPPING

The vehicle may be equipped with an inverter-charger or other automatic genset starting device (AGS). Always follow the instructions and safety precautions provided by the manufacturer of the automatic starting device when enabling automatic genset starting.

⚠WARNING **EXHAUST GAS is deadly. MOVING PARTS and ELECTRICITY can cause severe personal injury or death. To reduce exposure to these hazards, always disable automatic genset starting before:**

- **Sleeping, unless vehicle CO detector is enabled**
- **Parking vehicle in garage or confined space**
- **Parking vehicle for storage**
- **Servicing genset**
- **Servicing batteries**
- **Servicing electrical appliances**
- **Fueling vehicle**

LOADING THE GENSET

The genset can power AC motors, air conditioners, AC/DC converters and other loads. How much load* can be powered depends upon the genset power rating. The genset will shut down or its circuit breakers will trip if the sum of the loads exceeds genset power. See *Troubleshooting* (Page 30).

To avoid overloading the genset and causing shutdowns, compare the sum of the loads that are likely to be used at the same time to the power rating of the genset. ***It may be necessary to run fewer loads at the same time—the sum of the loads must not be greater than genset rating.***

Note that the genset may shut down due to overload when a large motor or air conditioner is started or

cycles off and then on again, even though the sum of the loads is less than genset rating. The reason for this is that a motor's startup load is much larger than its running load. ***It may be necessary to run fewer loads when large motors and air conditioners are cycling on and off.***

Note also that maximum power decreases as altitude increases because air density decreases. For every 1000-foot (305 m) increase in elevation you can expect power to decrease approximately 3 percent. Table 2 shows the results of typical calculations. ***It may be necessary to run fewer loads at higher altitudes.***

TABLE 2. POWER VS. ALTITUDE

Elevation above Sea Level	Maximum Power
at/below 500 ft (152 m)	5000 W (rated)
at 2500 ft (762 m)	4700 W
at 5500 ft (1676 m)	4250 W
above 5500 ft (1676 m)	4250 W minus 150 W every 1000 ft (305 m)

CONNECTING TO UTILITY POWER

A vehicle with provisions for connecting utility power must have an approved device to keep the genset and utility from being interconnected. See the genset Installation Manual for more information.

⚠WARNING ***Interconnecting the genset and the public utility (or any other power source) can lead to electrocution of utility line workers, equipment damage and fire. Use an approved switching device to prevent interconnections.***

* Equipment load and genset power are measured in terms of watts (W) or kilowatts (kW), where 1 kilowatt (kW) = 1000 watts (W).

RESETTING CIRCUIT BREAKERS

If a circuit breaker in the main power distribution panel of the vehicle or on the genset (Figure 5) trips, either a circuit shorted or too many loads were running. Note that the genset will continue to run after a circuit breaker trips.

If a circuit breaker trips, disconnect or turn off as many loads as possible and reset the circuit breaker. (Push the circuit breaker to **OFF** to reset it and then to **ON** to reconnect the circuit.) If the circuit breaker trips right away, either the electrical distribution system has a short or the circuit breaker is faulty. Call a qualified electrician.

If the circuit breaker does not trip, reconnect the loads, one by one, up to a total load that does not overload the genset or cause the circuit breaker to trip. If a circuit breaker trips right away when an appliance is connected, the load equipment probably has a short.

Electrical equipment and tools must be used and maintained properly and be properly grounded to cause the line circuit breakers to trip when short circuits occur.

⚠WARNING *Short circuits in electrical equipment and tools can cause fire and electrical shock*

leading to severe personal injury or death. Read and follow the equipment and tool manufacturer's instructions and warnings regarding use, maintenance and proper grounding.

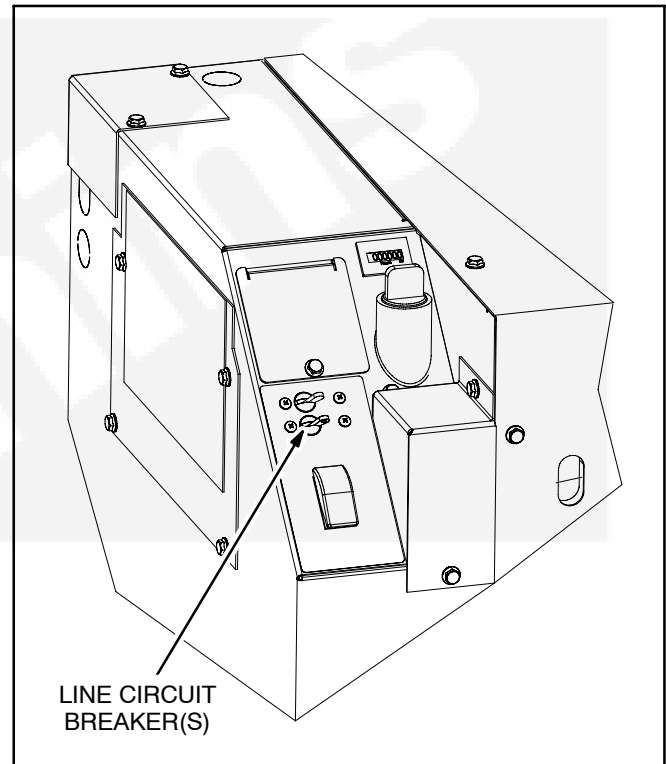

FIGURE 5. LINE CIRCUIT BREAKERS

OPERATING IN COLD WEATHER

Make sure the engine oil viscosity is appropriate for the cold weather temperatures. See ENGINE OIL RECOMMENDATIONS (Page 10). Be sure to change the oil if a sudden drop in temperature occurs.

OPERATING IN HOT WEATHER

Pay particular attention to the following items when operating the genset in hot weather:

1. Make sure nothing blocks airflow to and from the genset.
2. Make sure engine oil viscosity is appropriate for the ambient temperatures. See ENGINE OIL RECOMMENDATIONS (Page 9).
3. Keep the genset clean.
4. Perform maintenance due. See PERIODIC MAINTENANCE SCHEDULE (Page 20).

OPERATING AT HIGH ALTITUDE

For the effect of altitude on maximum power, see LOADING THE GENSET (Page 15).

OPERATING IN DUSTY ENVIRONMENTS

Pay particular attention to the following items when operating the genset in dusty environments:

1. Do not let dirt and debris accumulate inside the genset compartment. Keep the genset clean.
2. Perform air cleaner maintenance more often. See PERIODIC MAINTENANCE SCHEDULE (Page 20).

3. Change engine oil more often. See PERIODIC MAINTENANCE SCHEDULE (Page 20).
4. Keep containers of engine oil that have been opened tightly closed to keep out dust.

BREAKING IN A NEW ENGINE

Proper engine break-in on a new genset or on one with a rebuilt engine is essential for top engine performance and acceptable oil consumption. Run the genset at approximately 1/2 rated power for the first 2 hours and then at 3/4 rated power for 2 more hours.

Proper engine oil and oil level are especially critical during break-in because of the higher engine temperatures that can be expected. Change the oil if not appropriate for the ambient temperatures during break-in. See ENGINE OIL RECOMMENDATIONS (Page 9). Check oil level twice a day or every 4 hours during the first 24 hours of operation and change the oil and oil filter after the first 50 hours of operation.

EXERCISING THE GENSET

Exercise the genset at least 2 hours each month if use is infrequent. Run the genset at approximately 1/2 rated power. A single two hour exercise period is better than several shorter periods.

Exercising a genset drives off moisture, re-lubricates the engine, replaces stale fuel and removes oxides from electrical contacts. The result is better starting, more reliable operation and longer engine life.



STORING THE GENSET

Proper storage is essential for preserving top genset performance and reliability when the genset cannot be exercised regularly and will be idle for more than 120 days.

Storing the Genset

1. Push the genset line circuit breaker OFF (Page 16).
2. Change the engine oil and attach a tag indicating oil viscosity. See ENGINE OIL RECOMMENDATIONS (Page 9).
3. Disconnect the battery cables (negative [-] cable first) from the starting battery and store the battery according to the battery manufacturer's recommendations. See MAINTAINING THE BATTERY AND BATTERY CONNECTIONS (Page 24).
4. Plug the exhaust tail pipe to keep out dirt, moisture, bugs, etc.
5. Close the fuel supply valve (if so equipped).

Returning the Genset to Service

1. Check the oil tag on the genset and change the oil if the viscosity indicated is not appropriate for the temperatures expected. See ENGINE OIL RECOMMENDATIONS (Page 9).
2. Reconnect the starting battery (negative [-] cable last). See MAINTAINING THE BATTERY AND BATTERY CONNECTIONS (Page 24).
3. Remove the plug from the exhaust tailpipe.
4. Change the air filter element if it is dirty (Page 24).
5. Open the fuel supply valve (if so equipped).
6. Inspect the genset. See CONDUCTING GENERAL INSPECTIONS (Page 14).
7. Push the genset line circuit breaker ON (Page 16) when the genset is ready to power appliances.





This page is intentionally blank.



3.Periodic Maintenance

Periodic maintenance is essential for top performance and long genset life. Use Table 3 as a guide for normal periodic maintenance. In hot and dusty environments some maintenance procedures should be performed more frequently, as indicated by the footnotes in the table. Keeping a log of maintenance performed and hours run (Page 42) will help you keep

genset maintenance regular and provide a basis for supporting warranty claims.

Maintenance, replacement or repair of emission control devices and systems may be performed by any engine repair establishment or individual. However, warranty work must be completed by an authorized Cummins Onan dealer.

TABLE 3. PERIODIC MAINTENANCE SCHEDULE

MAINTENANCE OPERATION	MAINTENANCE FREQUENCY						Page
	Every Day	After First 50 Hours	Every Month	Every 150 Hours	Every 500 Hours	Every 1000 Hours	
General Inspection	•						21
Check Engine Oil Level	•						22
Check Engine Coolant Level	•						28
Clean and Check Battery			• ²				24
Clean Spark Arrestor				• ^{3, 7}			-
Change Engine Oil and Oil Filter		•		• ^{1, 2, 3, 4}			23
Replace Engine Air Filter					• ^{1, 3}		24
Replace Fuel Filter					• ³		25
Check Coolant Anti-Freeze Protection					• ³		21
Flush Coolant System						• ⁵	21
Replace Coolant Pressure Cap						• ⁵	21
Replace Engine V-belt (Coolant Pump)						• ^{6, 7}	-
Replace Coolant Hoses and Thermostat						• ^{6, 7}	-
Adjust Engine Valve Lash						• ^{6, 7}	-
Service Fuel Injectors						• ^{6, 7}	-
Check Generator Bearings, Drive Belt, Belt Tensioner & Drive Coupling						• ^{6, 7}	-

1 – Perform more often when operating in dusty conditions.

2 – Perform more often when operating in hot weather.

3 – Perform at least once a year.

4 – Perform every 75 hours when using high sulfur fuel. See ENGINE OIL RECOMMENDATIONS (Page 9).

5 – Perform at least once every two years.

6 – Perform at least once every five years.

7 – Must be performed by a qualified mechanic (authorized Cummins Onan dealer).

CONDUCTING GENERAL INSPECTIONS

Inspect the genset before the first start of the day and after every eight hours of operation.

Oil Level

Check engine oil level (Page 22).

Engine Coolant System

⚠ CAUTION *Operating the genset when coolant level is low can cause serious engine damage.*

Check the coolant level and look for coolant leaks around the bottom of the genset and on the ground below. Minor leaks that can be replenished by daily additions of coolant to the recovery tank should be repaired by a qualified service technician as soon as possible. Larger leaks are cause for shutting down the genset until it can be repaired.

Exhaust System

⚠ WARNING *EXHAUST GAS IS DEADLY! Do not operate the genset if there is an exhaust leak or any danger of exhaust gases entering or being drawn into the vehicle.*

Look and listen for exhaust system leaks while the genset is running. Shut down the genset if a leak is found and have it repaired before operating the genset again.

Look for openings or holes between the genset compartment and vehicle cab or living space if the genset engine sounds louder than usual. Have all such openings or holes closed off or sealed to prevent exhaust gases from entering the vehicle.

Replace dented, bent or severely rusted sections of the tailpipe and make sure the tailpipe extends at least 1 inch (25.4 mm) beyond the perimeter of the vehicle.

Check all CO monitors to assure proper operation.

⚠ WARNING *Do not park the vehicle in high grass or brush. Contact with the exhaust system can cause a fire.*

Park the vehicle so that the genset exhaust gases can disperse away from the vehicle. Barriers such as walls, snow banks, high grass and brush and other vehicles can cause exhaust gases to accumulate in and around the vehicle.

Do not operate power ventilators or exhaust fans while the vehicle is standing with the genset running. The ventilator or fan can draw exhaust gases into the vehicle.

Fuel System

Check for leaks at hose, tube and pipe fittings in the fuel supply system while the genset is running and while it is stopped. Check flexible fuel hose sections for cuts, cracks, and abrasions. Make sure the fuel line is not rubbing against other parts. Replace worn or damaged fuel line parts before leaks occur.

⚠ WARNING *Diesel fuel leaks can lead to fire. Do not operate the genset if operation causes fuel to leak.*

Prime the fuel system if the genset ran out of fuel.

Battery Connections

Check the battery terminals for clean, tight connections. Loose or corroded connections have high electrical resistance which makes starting harder. See MAINTAINING THE BATTERY AND BATTERY CONNECTIONS (Page 24).

Mechanical

Visually inspect genset for mechanical damage. For generator sets with a sound shield, install service doors before running the generator set to listen for unusual noises. Check the genset mounting bolts. Check to see that the generator set air inlet and outlet openings are not clogged with debris or blocked. Keep the generator set compartment clean.

To prevent overheating and to reduce fouling with dust and debris, make sure the genset's normal ground clearance is not being reduced by sloping ground, curbs, logs or other objects. Repark the vehicle if necessary and/or remove any objects blocking the air inlet or air outlet.

CHECKING ENGINE OIL LEVEL

Park the vehicle on level ground and shut off the genset before checking engine oil level.

⚠️WARNING *State and federal agencies have determined that contact with used engine oil can cause cancer or reproduce toxicity. Avoid skin contact and breathing of vapors. Use rubber gloves and wash exposed skin.*

⚠️WARNING *Crankcase pressure can blow hot engine oil out the fill opening causing severe burns. Always stop the genset before removing the oil fill plug or drain.*

⚠️CAUTION *Too much oil can cause high oil consumption. Too little oil can cause severe engine damage. Keep the oil level between the high and low beads on the dipstick.*

1. Pull the plug and dipstick out of the oil fill neck (Figure 6). The plug may be difficult to pull straight out. It is easier if you tilt the plug in its socket while pulling out. Wipe off the dipstick and thread it back into the fill neck and seat the plug, which snaps into its socket. Remove the plug and dipstick again and check the oil level on the dipstick.
2. Add or drain oil as necessary. See ENGINE OIL RECOMMENDATIONS (Page 9). Keep the oil level between the high and low beads on the end of the dipstick, as shown. It is not necessary to add oil between oil changes if the oil has not dropped more than 1/3 of the way between the high and low beads. Approximately 1 pint (0.4 liter) can be added if the oil level is at the lower bead.

3. Secure the oil fill plug, which snaps into its socket.

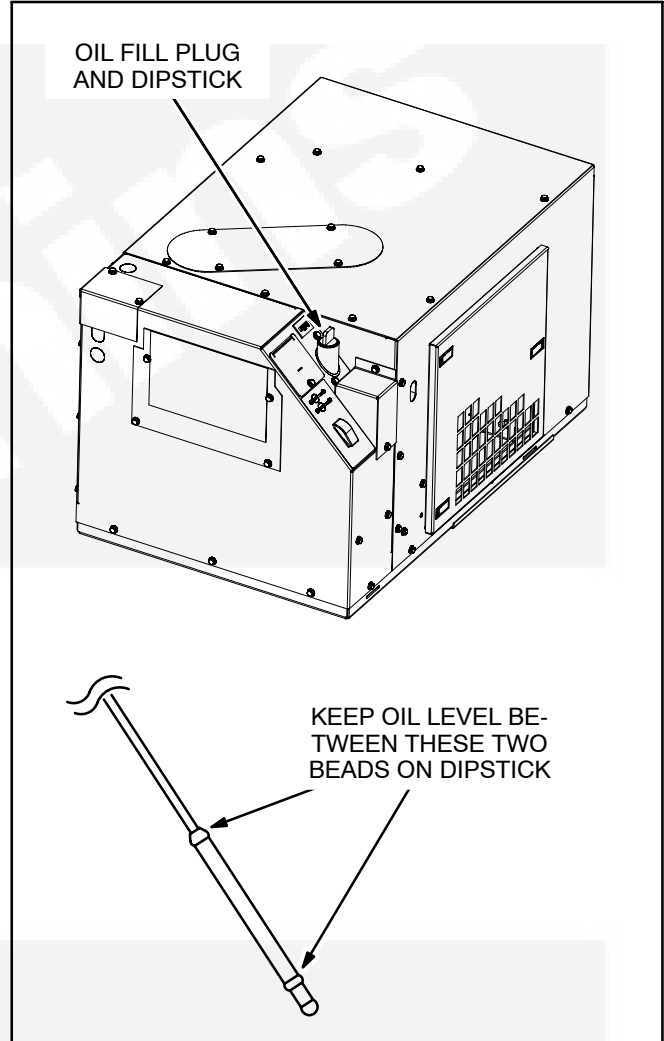

FIGURE 6. CHECKING ENGINE OIL LEVEL

CHANGING ENGINE OIL AND FILTER

Refer to Table 3 for scheduled engine oil change. Change oil more often in hot and dusty environments.

⚠WARNING State and federal agencies have determined that contact with used engine oil can cause cancer or reproductive toxicity. Avoid skin contact and breathing of vapors. Use rubber gloves and wash exposed skin.

⚠WARNING To prevent accidental or remote starting while working on the genset, disconnect the negative (-) battery cable at the battery.

⚠WARNING Do not run the genset with the maintenance access covers off. Contact with hazardous moving parts and hot exhaust manifolds can cause severe personal injury.

⚠WARNING Engine components (drains, filters, hoses, etc) will be hot and can cause severe burns. The use of protective gloves is recommended.

1. Run the genset until warm and shut it off.
2. Pull the oil dipstick (Page 22) out a couple of inches (50 mm) so that the oil will drain faster.
3. Remove the front and bottom access covers (Figures 7 and 8) and direct the end of the drain hose into a container.
4. Open the drain valve to drain all of the old oil.
5. **Close the drain valve.**
6. Spin off the oil filter and clean the filter mounting surface on the engine block. Remove the old gasket if it remains. (The oil filter is easier to remove through the front access opening.)
7. Make sure the gasket is in place on the new filter and apply a thin film of clean oil to the gasket. Spin the new filter on until the gasket just touches the block. Turn it an additional 1/2 to 3/4 turn. Do not over tighten.
8. Refill with 2 quarts (1.9 liters) of oil and check the level (Page 22).
9. Secure the maintenance access covers for proper engine cooling and for protection from hazardous moving parts and hot exhaust manifolds.

10. Dispose of the used oil and oil filter according to local environmental regulations.

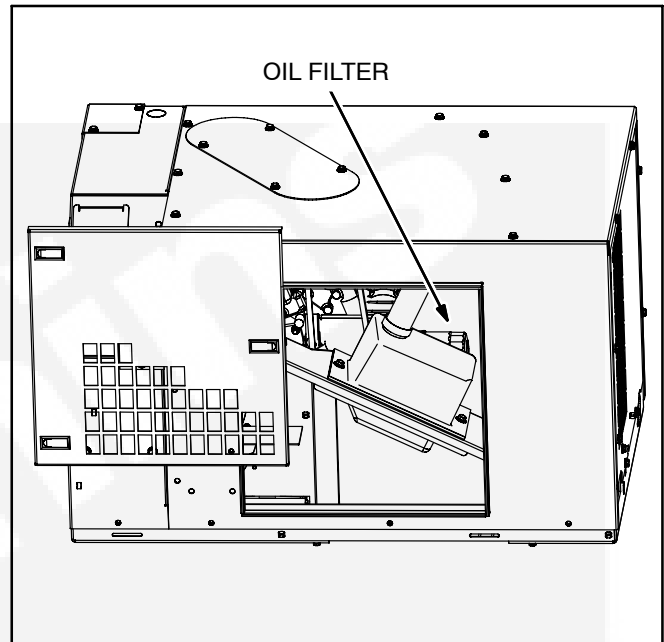

FIGURE 7. OIL FILTER ACCESS THROUGH FRONT

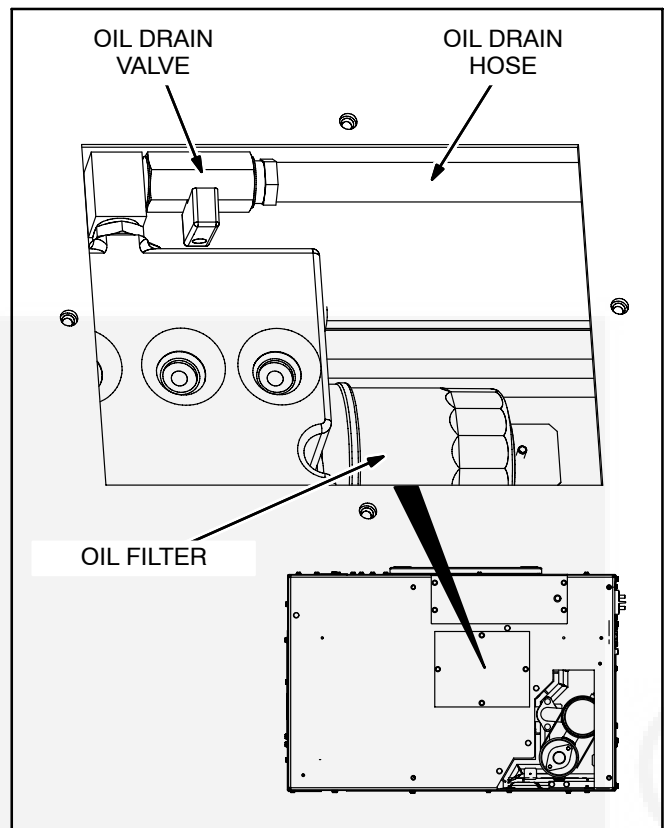

FIGURE 8. OIL DRAIN VALVE, DRAIN HOSE AND FILTER ACCESS THROUGH BOTTOM

MAINTAINING BATTERY AND BATTERY CONNECTIONS

Refer to Table 3 for scheduled battery maintenance, and follow the battery manufacturer's instructions. Have the battery charging system serviced if DC system voltage is consistently low or high. Always:

⚠WARNING *Arcing at battery terminals or in light switches or other equipment, and flames or sparks, can ignite battery gas causing severe personal injury. To prevent injury:*

- *Ventilate battery area before working on or near battery*
- *Wear safety glasses*
- *Do not smoke*
- *Switch work light ON or OFF away from battery*
- *Stop genset and disconnect charger before disconnecting battery cables*
- *Disconnect negative (-) cable first and reconnect it last.*

1. Keep the battery case and terminals clean and dry and the terminals tight.
2. Remove battery cables with a battery terminal puller.
3. Make sure which terminal is positive (+) and which is negative (-) before making battery con-

nections, always removing the negative (-) cable first and reconnecting it last to reduce arcing.

REPLACING AIR FILTER ELEMENT

Refer to Table 3 for scheduled air filter element replacement. In dusty environments the filter element should be inspected and changed more frequently.

⚠WARNING *To prevent accidental or remote starting while working on the genset, disconnect the negative (-) battery cable at the battery.*

⚠WARNING *Do not run the genset with the maintenance access covers off. Contact with hazardous moving parts and hot exhaust manifolds can cause severe personal injury.*

Remove the front access door, unscrew the 2 wing-nuts on the filter housing and pull away the filter housing and filter element (Figure 9).

When installing the new filter element, turn the wing-nuts hand tight.

Secure the maintenance access covers for proper engine cooling and for protection from hazardous moving parts and hot exhaust manifolds.

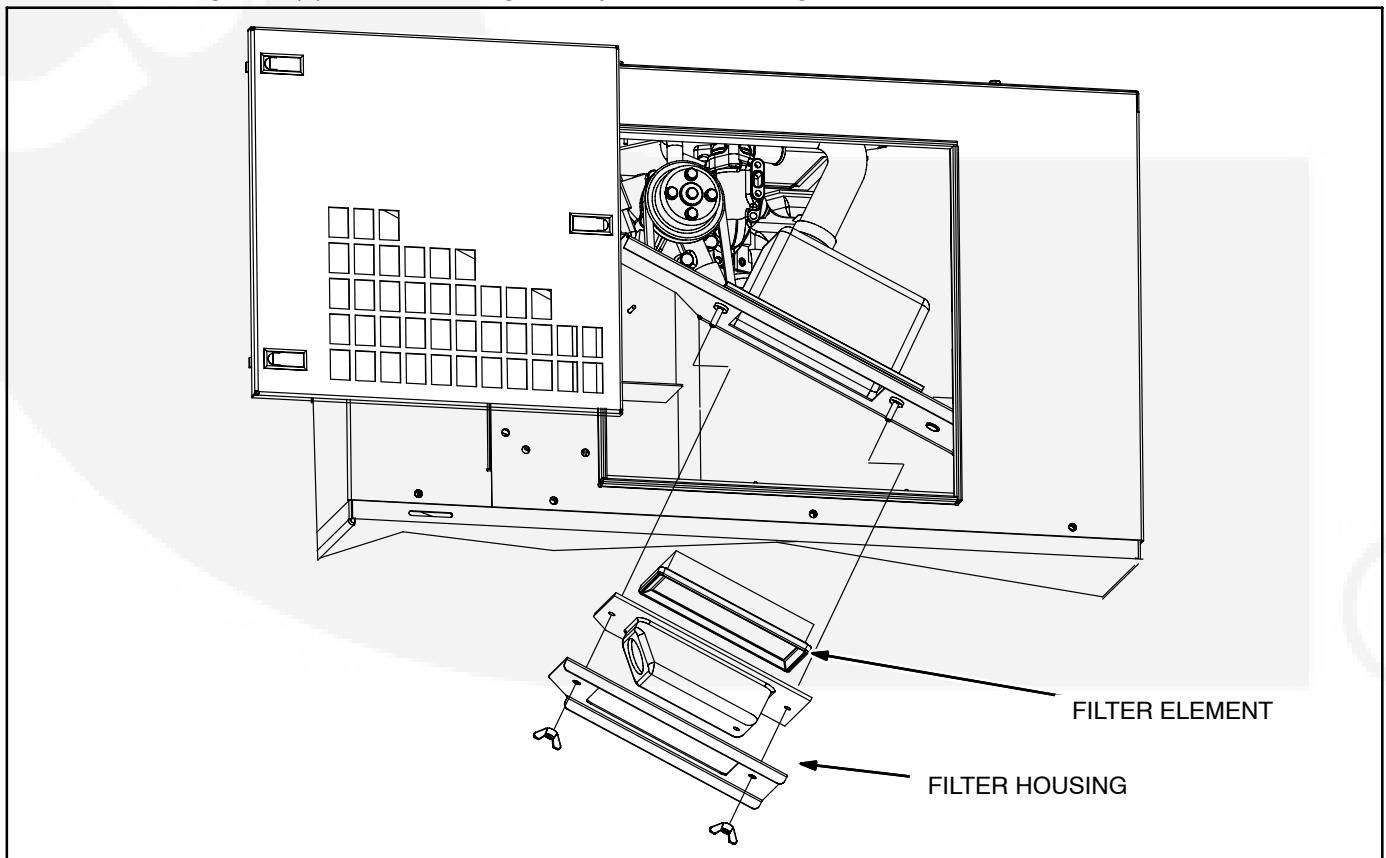

FIGURE 9. REPLACING THE AIR FILTER ELEMENT

REPLACING FUEL FILTER

See Table 3 for scheduled fuel filter replacement. A dirty fuel filter may be the cause of a failure to start. The fuel filter is accessible through the bottom access opening (Figure 10).

⚠WARNING *Diesel fuel is combustible and can cause severe personal injury or death. Do not smoke near diesel fuel tanks or equipment. Keep flames, sparks, pilot lights, electrical switches, arc-producing equipment and all other sources of ignition well away. Keep a type ABC fire extinguisher in the vehicle.*

⚠WARNING *To prevent accidental or remote starting while working on the genset, disconnect the negative (-) battery cable at the battery.*

⚠WARNING *Engine components (drains, filters, hoses, etc) will be hot and can cause severe burns. The use of protective gloves is recommended.*

⚠WARNING *Do not run the genset with the maintenance access covers off. Contact with hazardous moving parts and hot exhaust manifolds can cause severe personal injury.*

Removing the Fuel Filter

Take care to spill as little fuel as possible when disconnecting the filter from the fuel line. Close any shut off valve in the fuel line. Use paper towels to clean the two fuel line fittings and absorb any fuel that spills.

To remove the filter, disconnect the two fittings at the filter. *Use two flarenut wrenches on each fitting so as not to round the corners or stress the fittings.* Then remove the filter mounting nut and two (2) bracket mounting screws. Dispose of the fuel filter and paper towels according to local regulations.

Installing the Fuel Filter

Secure the bracket loosely to the new filter. The filter and its bracket fit properly only one way.

Loosely secure the filter and bracket to the base with the two mounting screws and re-connect the fuel fittings. Take care not to cross thread the fuel fittings. Thread them in by hand and tighten one flat past seating. Finally, tighten the bracket and bracket mounting screws.

Prime the fuel system by holding the control switch down in its **Stop** position for at least 1 minute. Priming is necessary to fill the new filter with fuel.

Secure the maintenance access covers for proper engine cooling and for protection from hazardous moving parts and hot exhaust manifolds.



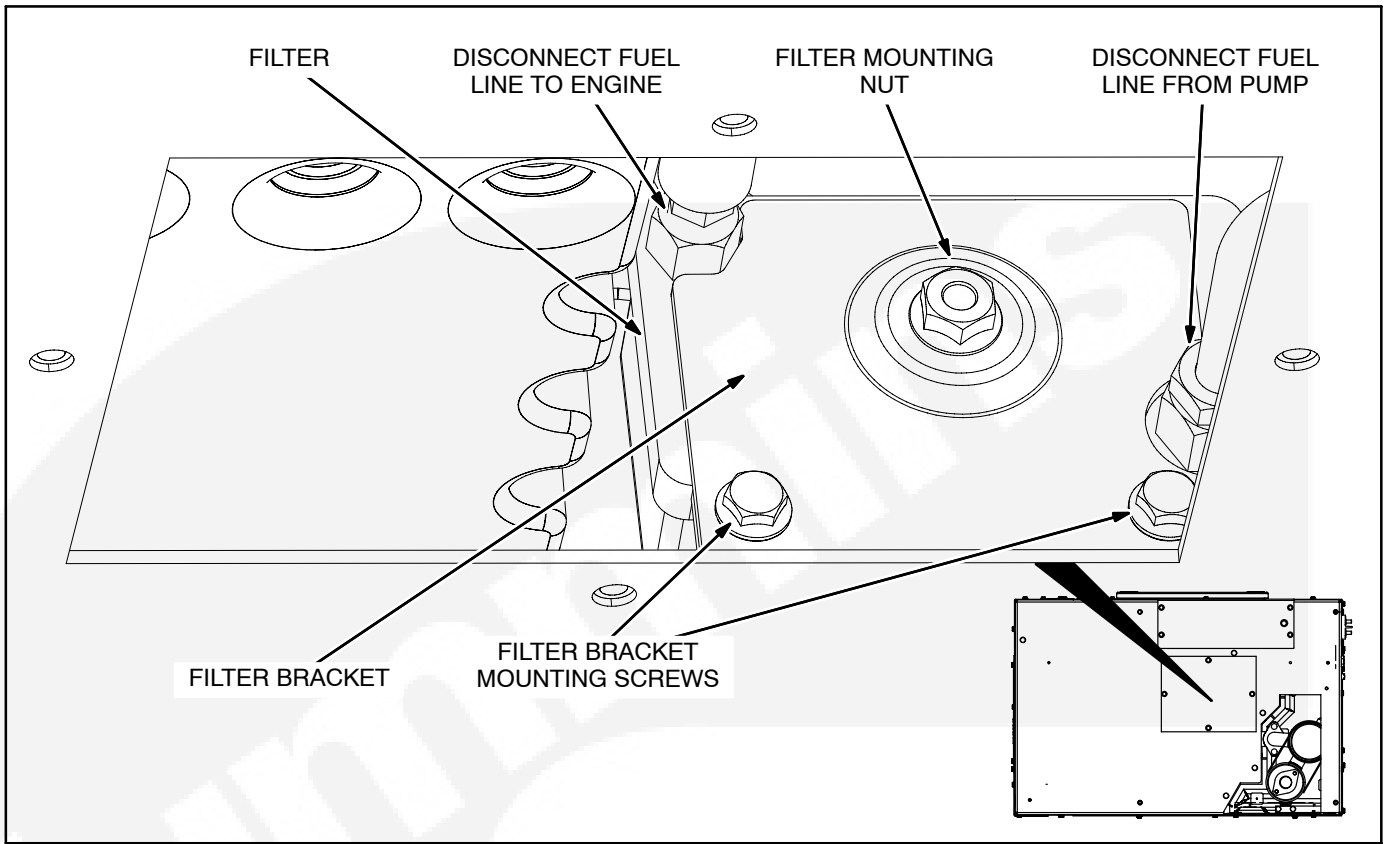

FIGURE 10. FUEL FILTER

CHANGING COOLANT

Refer to Table 3 for scheduled maintenance. The engine cooling system is filled with a 50/50 mixture of ethylene glycol and water at the factory, which is suitable for temperatures down to -34° F (-37° C).

Recommended Coolant Mixture

Use the best quality ethylene glycol antifreeze solution available. It should be fully formulated with rust inhibitors and coolant stabilizers. Use fresh water that is low in minerals and corrosive chemicals. Distilled water is best.

⚠WARNING *Hot coolant spray can cause severe burns. Let the engine cool before releasing the pressure cap or opening the drain cock.*

Replacing the Pressure Cap

Replace the pressure cap (Figure 12) every two years (seals deteriorate and leak). Proper cooling system pressure (14 psi) is essential for optimal engine cooling and minimal coolant loss.

Draining the Cooling System

⚠WARNING *To prevent accidental or remote starting while working on the genset, disconnect the negative (-) battery cable at the battery.*

⚠WARNING *Engine components (drains, filters, hoses, etc) will be hot and can cause severe burns. The use of protective gloves is recommended.*

Let the engine cool before removing the pressure cap. Relieve any remaining pressure by turning the pressure cap slowly, without pushing down. To remove the cap, push down and turn it the rest of the way. Then remove the bottom access cover (Figure 11), open the radiator drain cock and drain the coolant into a suitable container. Approximately 1.6 quarts (1.5 L) will drain.

⚠WARNING *Ethylene glycol antifreeze is considered toxic. Dispose of it according to local regulations for hazardous substances.*

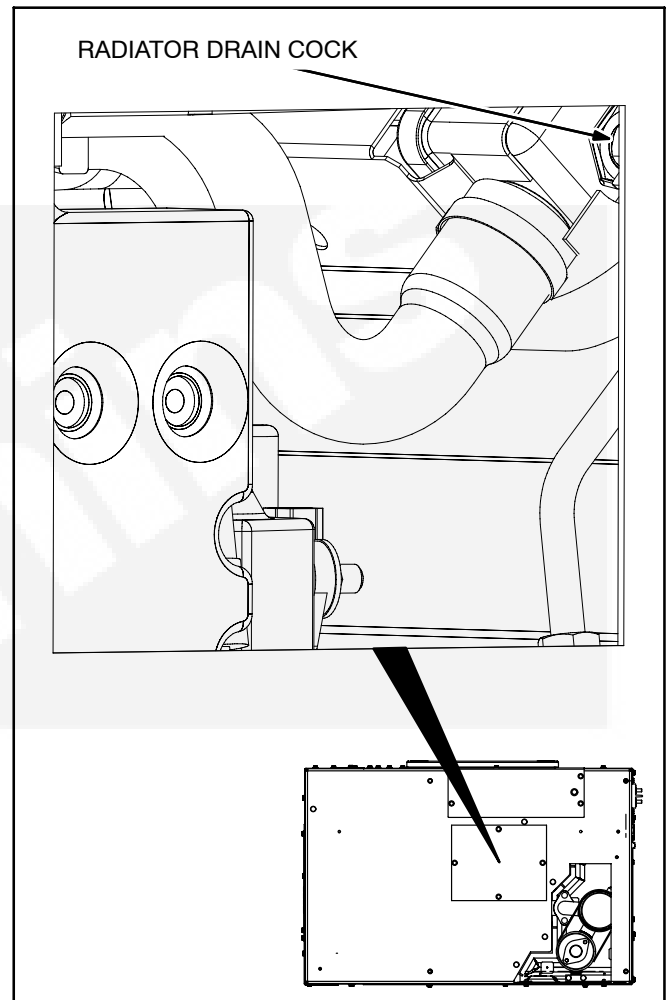

FIGURE 11. LOWER RADIATOR HOSE

Cleaning the Cooling System

Clean and flush the cooling system with radiator cleaning chemicals available at auto parts stores. Follow the instructions for cleaning and flushing that come with the cleaning solution.

Refilling the Cooling System

Close the radiator drain cock. Pull the hose connected to the pressure cap assembly out as far and as high as it will go (Figure 12). Remove the pressure cap and fill the system using a funnel inserted into the fill hose to prevent coolant from entering the vent hose and blocking the escape of air as the system fills. The system *will seem full when it actually is not* if the air cannot escape through the vent hose. If the vent hose does get blocked, pinch the overflow hose and blow the vent hose clear. Start and operate the genset for a few minutes while keeping the fill opening elevated to promote venting of air from the coolant. Shut down the genset and add coolant as neces-

sary. Secure the pressure cap and fill the recovery tank to the COLD mark.

⚠ CAUTION *Coolant trapped in the vent hose will prevent the system from filling to its capacity, which can lead to serious engine damage.*

Secure the maintenance access covers for proper engine cooling and for protection from hazardous moving parts and hot exhaust manifolds.

⚠ WARNING *Do not run the genset with the maintenance access covers off. Contact with hazardous moving parts and hot exhaust manifolds can cause severe personal injury.*

Fill the recovery tank with coolant mixture to the COLD mark.

Checking Coolant Level

Check coolant level in the recovery tank (Figure 12) before the first startup of each day and fill to the COLD mark if necessary.

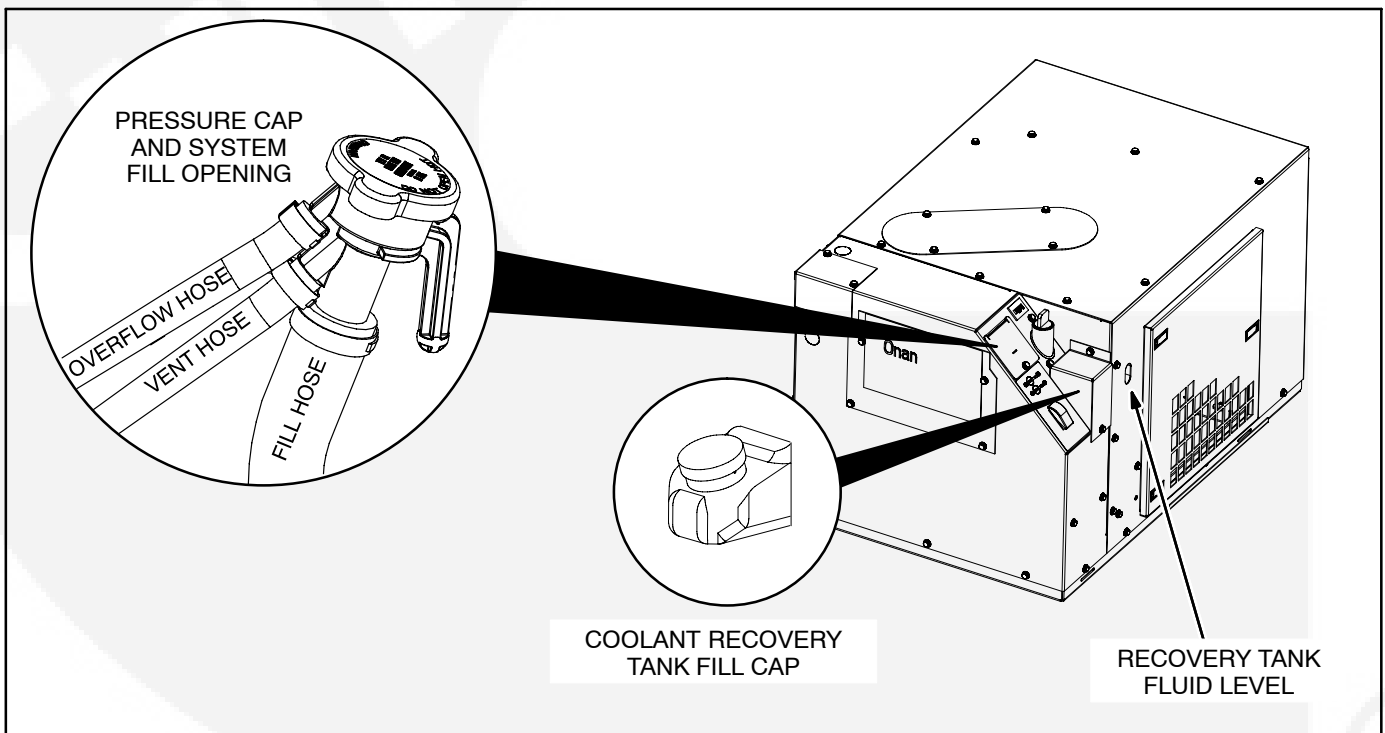

FIGURE 12. ENGINE COOLING SYSTEM PRESSURE CAP AND RECOVERY TANK



This page is intentionally blank.



4. Troubleshooting

TABLE 4. TROUBLESHOOTING lists the shutdown codes in numerical order along with step-by-step corrective actions. If you are unable to resolve the problem after taking the corrective actions suggested, contact an authorized Cummins Onan dealer. See *How to Obtain Service* (Page 40).

First note the following:

- Maintaining engine oil and coolant levels, keeping battery connections clean and tight, watching the fuel gauge, not overloading the genset, keeping the air inlet and outlet openings clear, etc. will prevent most shutdowns.
- When the genset and vehicle engine share a common fuel tank the fuel dip tubes are usually arranged so that the genset will run out of fuel first. Marking the genset empty point on the fuel gauge will make it easier to tell when to stop the genset before running it out of fuel.

SHUTDOWN CODES

The genset controller provides extensive diagnostics by causing the status indicator light on the Control Switch to blink in a coded fashion. Following a fault shutdown, the indicator light will repeatedly blink 1, 2, 3 or 4 blinks at a time.

- **One blink** indicates shut down due to high temperature.

- **Two blinks** indicate shutdown due to a loss of engine oil pressure.

- **Three blinks** indicate a service fault. Press **Stop** once to cause the two-digit, second-level shutdown code to blink. (Pressing **Stop** again will stop the blinking.) The two-digit code consists of 1, 2, 3, 4 or 5 blinks, a brief pause, and then 1 to 9 blinks. The first set of blinks represents the tens digit and the second set of blinks the units digit of the shutdown code number. For example, **shutdown code No. 36** appears as:

blink-blink-blink—*pause*—blink-blink-blink-blink-blink-blink—*long pause*—repeat

- **Four blinks** indicate that cranking exceeded a preset time (20 seconds if ambient temperature is above 32° F[0° C], 30 seconds if below) without starting.
- **Note: shutdown code Nos. 3 and 4 are first level faults. Avoid interpreting them as second-level shutdown code Nos. 33 and 44, which have not been assigned as shutdown codes.**

Restoring Shutdown Code Blinking – The shutdown code stops blinking after five minutes. Press **Stop** three times within three seconds to restore blinking. **Note that the last fault logged will blink, even after the condition that caused the shutdown has been corrected.**



TABLE 4. TROUBLESHOOTING

⚠ WARNING *Some genset service procedures present hazards that can result in severe personal injury or death. Only trained and experienced service personnel with knowledge of fuels, electricity, and machinery hazards should perform genset service. See Safety Precautions.*

NO RESPONSE—DEAD STATUS INDICATOR LIGHT

(Poor connections, faulty wiring or dead battery)

Corrective Action:

1. Try starting the genset at the operator's console if it does not start at the remote panel.
2. Clean and tighten the battery cable connections at the battery and at the genset.
3. Recharge or replace the battery. Refer to the battery manufacturer's recommendations.

THE STARTING BATTERIES DO NOT MAINTAIN A CHARGE

(The battery, battery connections or charging system are in marginal condition)

Corrective Action:

1. Clean and tighten the battery cable connections at the battery and at the genset.
2. Recharge or replace the battery. Refer to the battery manufacturer's recommendations.

THE STARTER ENGAGES AND DISENGAGES

(Cranking voltage dips below 6 volts because of low battery charge or poor connections)

Corrective Action:

1. Have the vehicle propulsion engine running while trying to start the genset. (The battery charging alternator may be able to maintain starting voltage high enough to get the genset started.)
2. Clean and tighten the battery cable connections at the battery and at the genset.
3. Recharge or replace the battery. Refer to the battery manufacturer's recommendations.

THERE IS NO POWER WHEN THE GENSET IS RUNNING

(A line circuit breaker is OFF, tripped or malfunctioning)

Corrective Action:

1. Reset or turn ON the line circuit breaker on the genset (Page 16).
2. Reset or turn ON any other circuit breaker in the power supply system.

THE GENSET WILL NOT STOP RUNNING (THE RUN LIGHT IS OFF)

(The governor mechanism is stuck or binding)

Corrective Action: Close the fuel supply valve, if provided, or squeeze off the fuel supply line and see an authorized Cummins Onan dealer.

TABLE 4. TROUBLESHOOTING (CONT.)

⚠ WARNING *Some genset service procedures present hazards that can result in severe personal injury or death. Only trained and experienced service personnel with knowledge of fuels, electricity, and machinery hazards should perform genset service. See Safety Precautions.*

HIGH TEMPERATURE FAULT—CODE NO. 1

(First-level fault code—engine coolant temperature exceeded 230° F [110° C])

Corrective Action:

1. Check the engine coolant level and add coolant as necessary (Page 28).
2. Check for and remove any objects blocking the air inlet or outlet openings in the bottom and sides of the genset.
3. Flush the coolant system to remove coolant passage fouling (Page 27).

LOW OIL PRESSURE FAULT—CODE NO. 2

(First-level fault code—the low oil pressure cutoff switch is open)

Corrective Action:

1. Check the engine oil level and add oil as necessary (Page 22).
2. Drain the excess oil if the oil level is above the Full mark on the dipstick. (The oil will foam if the level is too high and result in possible loss of oil pressure.)

SERVICE CHECK—CODE NO. 3

(First-level fault code—a second-level fault occurred)

Corrective Action: Check the second-level fault code by momentarily pressing Stop. The second-level fault will be one of the following in this table.

OVERCRANK FAULT—CODE NO. 4

(First-level fault code—Cranking without starting exceeded 20 to 30 seconds, depending on ambient)

Corrective Action:

1. Check the fuel level and refill as necessary. (Note: The genset fuel pickup is probably higher than the vehicle engine fuel pickup.)
2. Check for fuel (air) leaks at all fuel fittings and tighten as necessary. Prime the engine fuel system by holding the control switch at **Stop** for one minute.
3. Check the engine air filter (Page 24) and remove any blockage.
4. Check for mechanical damage.
5. Replace the fuel filter (Page 26).

OVERVOLTAGE FAULT—CODE NO. 12

(The controller is not able to regulate to rated voltage)

Corrective Action: See an authorized Cummins Onan dealer.

TABLE 4. TROUBLESHOOTING (CONT.)

⚠ WARNING *Some genset service procedures present hazards that can result in severe personal injury or death. Only trained and experienced service personnel with knowledge of fuels, electricity, and machinery hazards should perform genset service. See Safety Precautions.*

UNDERVOLTAGE FAULT—CODE NO. 13

(The controller is not able to regulate to rated voltage)

Corrective Action: Turn OFF the line circuit breaker on the operator's console. If the genset now runs, run it with fewer connected loads.

OVERFREQUENCY FAULT—CODE NO. 14

(The controller is not able to regulate to rated frequency)

Corrective Action:

1. Check for a tripped genset circuit breaker, reset it if necessary, and run with fewer connected loads. (A breaker tripping under load can cause frequency to overshoot.)
2. Check for fuel (air) leaks at all fuel fittings and tighten as necessary. Prime the engine fuel system by holding the control switch at **Stop** for one minute. (Air bubbles can disrupt frequency.)

UNDERFREQUENCY FAULT—CODE NO. 15

(The controller is not able to regulate to rated frequency)

Corrective Action:

1. Turn OFF the line circuit breaker. If the genset now runs, run it with fewer connected loads, especially those with high motor starting loads such as air conditioners.
2. Check the fuel level and refill as necessary. (Note: The genset fuel pickup is probably higher than the vehicle engine fuel pickup.)
3. Check for fuel (air) leaks at all fuel fittings and tighten as necessary. Prime the engine fuel system by holding the control switch at **Stop** for one minute. (Air bubbles can disrupt frequency.)
4. Check the engine air filter (Page 24) and remove any blockage.
5. Check for mechanical damage.
6. Replace the fuel filter (Page 26).

GOVERNOR ACTUATOR FAULT—CODE NO. 19

(The controller sensed that the actuator circuit is either open or shorted)

Corrective Action: See an authorized Cummins Onan dealer.

TABLE 4. TROUBLESHOOTING (CONT.)

⚠ WARNING *Some genset service procedures present hazards that can result in severe personal injury or death. Only trained and experienced service personnel with knowledge of fuels, electricity, and machinery hazards should perform genset service. See Safety Precautions.*

GOVERNOR OVERLOAD FAULT—CODE NO. 22

(The duration of operation at or near full-duty cycle was beyond the design limit)

Corrective Action:

1. Reduce the number of appliances running at the same time, especially those with high motor starting loads such as air conditioners.
2. Check for fuel (air) leaks at all fuel fittings and tighten as necessary. Prime the engine fuel system by holding the control switch at **Stop** for one minute.
3. Replace the engine air filter (Page 24) .
4. Replace the fuel filter (Page 26).

TEMPERATURE SENDER FAULT—CODE NO. 24

(The controller sensed that the sender circuit is either open or shorted)

Corrective Action: See an authorized Cummins Onan dealer.

AC VOLTAGE SENSE FAULT—CODE NO. 27

(The controller was unable to sense output voltage)

Corrective Action: See an authorized Cummins Onan dealer.

HIGH BATTERY VOLTAGE FAULT—CODE NO. 29

(The controller sensed battery system voltage greater than 19 volts)

Corrective Action:

1. Check battery bank connections and reconnect, if necessary, so that the 12 volt batteries serving the genset are connected in parallel (12 volt) rather than in series (24 volt).
2. Select a lower battery booster charge rate.

LOW CRANKING SPEED FAULT—CODE NO. 32

(Cranking speed less than 100 rpm [2.5 Hz, generator] for more than 12 seconds)

Corrective Action:

1. Have the vehicle propulsion engine running while trying to start the genset. (The battery charging alternator may be able to maintain starting voltage high enough to get the genset started.)
2. Clean and tighten the battery cable connections at the battery and at the genset.
3. Recharge or replace the battery. Refer to the battery manufacturer's recommendations.
4. Replace engine oil with oil of proper viscosity for ambient temperatures. (High oil viscosity can slow down cranking speed.)

TABLE 4. TROUBLESHOOTING (CONT.)

⚠ WARNING *Some genset service procedures present hazards that can result in severe personal injury or death. Only trained and experienced service personnel with knowledge of fuels, electricity, and machinery hazards should perform genset service. See Safety Precautions.*

CONTROL CARD FAULT—CODE NO. 35
(Microprocessor EEPROM error during self-test)

Corrective Action: See an authorized Cummins Onan dealer.

ENGINE STOPPED FAULT—CODE NO. 36
(The genset stopped without a command from the controller)

Corrective Action:

1. Check the fuel level and refill as necessary. (Note: The genset fuel pickup is probably higher than the vehicle engine fuel pickup.)
2. Check for fuel (air) leaks at all fuel fittings and tighten as necessary. Prime the engine fuel system by holding the control switch at **Stop** for one minute.
3. Check the engine air filter (Page 24) and remove any blockage.
4. Check for mechanical damage.
5. Replace the fuel filter (Page 26).

FIELD OVERLOAD FAULT—CODE NO. 38
(Field voltage exceeded 150 VDC)

Corrective Action:

1. Reduce the number of air conditioners running at the same time (and other appliances that cause low power factor).
2. Have the air conditioners and other appliances checked for proper operation. (A locked compressor rotor can cause very low power factor.)

SHORTED ROTOR FAULT—CODE NO. 41
(The rotor circuit is shorted to ground)

Corrective Action: See an authorized Cummins Onan dealer.

PROCESSOR FAULT—CODE NO. 42
(Microprocessor ROM error during self-test)

Corrective Action: See an authorized Cummins Onan dealer.

PROCESSOR FAULT—CODE NO. 43
(Microprocessor RAM error during self-test)

Corrective Action: See an authorized Cummins Onan dealer.

TABLE 4. TROUBLESHOOTING (CONT.)

⚠ WARNING *Some genset service procedures present hazards that can result in severe personal injury or death. Only trained and experienced service personnel with knowledge of fuels, electricity, and machinery hazards should perform genset service. See Safety Precautions.*

SPEED SENSE FAULT—CODE NO. 45
(Controller unable to sense quadrature frequency)

Corrective Action: Check the fuel level and fill as necessary. Then prime the engine fuel system by holding the control switch at **Stop** for one minute and try restarting.

OVERPRIME FAULT—CODE NO. 57
(Prime mode exceeded 3 minutes)

Corrective Action: Check for and remove any object that may be holding either control switch (remote or local) in the prime (stop) position.



This page is intentionally blank.



5. Specifications

	HDKBB	HDKBC
GENSET CONTROLLER: Integrated Microprocessor Based Engine and Generator Controller		
GENERATOR: Two-Bearing, Two-Pole Rotating Field, "Poly-Vee" Belt Drive		
Power (@1.0 PF)	4800 W	5000 W
RPM	3000	3600
Frequency	50 Hz	60 Hz
Voltage	230V 1-Ph	120V 1-Ph, 120/240V 1-Ph, or 120/240V 3-Ph
Current	21 A	41.7/20.8 A or 12 A (3-Ph)
Circuit Breakers	2-pole 25 A (1 pole used)	2-pole 25 A (1-Ph) or 3-pole 15 A (3-Ph)
FUEL CONSUMPTION:		
No-load	0.20 gph (0.74 lph)	0.25 gph (0.95 lph)
Half-load	0.32 gph (1.23 lph)	0.39 gph (1.47 lph)
Full-load	0.54 gph (2.04 lph)	0.60 gph (2.27 lph)
ENGINE: 2-Cylinder In-Line, Water-Cooled, Indirect-Injection, 4-Stroke Cycle Diesel		
RPM	2880	2880
Bore	2.64 in (67 mm)	2.64 in (67 mm)
Stroke	2.68 in (68 mm)	2.68 in (68 mm)
Displacement	29.23 in ³ (479 cc)	29.23 in ³ (479 cc)
Compression Ratio	23 : 1	23 : 1
Injection Order	1-2	1-2
Engine Timing	18.25° to 19.75° BTDC	18.25° to 19.75° BTDC
Fuel Nozzle Injection Pressure	1991 psi (13.73 mPa)	1991 psi (13.73 mPa)
Valve Lash: Intake & Exhaust (cold)	0.0057 – 0.0073 inch (0.145 – 0.185 mm)	0.0057 – 0.0073 inch (0.145 – 0.185 mm)
Oil Capacity (with filter)	2 quart (1.9 liter)	2 quart (1.9 liter)
Cooling System Capacity	3.0 quart (2.8 liter)	3.0 quart (2.8 liter)
DC SYSTEM:		
Nominal Battery Voltage	12 volts	12 volts
Minimum Battery Capacity CCA (Cold Cranking Amps)	475 amps down to 0° F (-17° C) 650 amps down to -20° F (-29° C)	475 amps down to 0° F (-17° C) 650 amps down to -20° F (-29° C)
Fuse F1 (control, start and glow plug circuits)	30 amp mini-bayonet	30 amp mini-bayonet
WEIGHT: 400 lbs (181 kg)		
SIZE (L x W x H): 34.5 x 22.9 x 20.3 in (876 x 581.2 x 514.4 mm)		
SOUND LEVEL: 68 dB(A) @ 10 ft (3m) before installation and @ 1/2-load		



This page is intentionally blank.



6. How to Obtain Service

When you call for service, parts, or product literature (such as the Service Manual or Parts Catalog) for your genset, contact the nearest authorized Cummins Onan distributor. Cummins Onan has factory-trained representatives to handle your requests for genset parts and service. For information for contacting our distributors worldwide, go to internet site www.cumminsonan.com.

In North America

Call 1-800-888-6626 to contact the nearest Cummins Onan distributor in the United States or Canada. (This automated service utilizes touch-tone phones only). Select OPTION 1 (press 1) to be automatically connected to the distributor nearest to you.

If you are unable to contact a distributor using the automated service, consult the Yellow Pages. Typically, our distributors are listed under:

GENERATORS – ELECTRIC,
ENGINES – GASOLINE OR DIESEL, or

RECREATIONAL VEHICLES – EQUIPMENT,
PARTS AND SERVICE.

If you have difficulty in arranging service or resolving a problem, please contact the Service Manager at the nearest Cummins Onan distributor for assistance.

Outside North America

If you are outside North America, call Cummins Onan at 1-763-574-5000 from 7:30 AM to 4:00 PM, Central Standard Time, Monday through Friday, or fax 1-763-528-7229.

Information to Have Ready

Before calling for service, have the following information available:

1. *The complete genset model number and serial number. See Model Identification (Page 4).*
2. *The date of purchase*
3. *The nature of the problem. See Troubleshooting (Page 30).*





This page is intentionally blank.



7. Maintenance Record

Record all periodic and unscheduled maintenance and service. See *Periodic Maintenance* (Page 20).

DATE	HOUR METER READING	MAINTENANCE OR SERVICE PERFORMED

Record the name, address, and phone number of your authorized Cummins Onan service center.



This page is intentionally blank.



Cummins **Onan**

Cummins Power Generation

1400 73rd Ave. NE
Minneapolis, MN 55432 USA

Phone 1 763 574 5000

Toll-free 1 800 888 6626

Fax 1 763 574 5298

Email www.cumminsonan.com/contact

www.cumminsonan.com

Cummins®, Onan®, the "C" logo, and "Performance you rely on." are trademarks of Cummins Inc.

©2010 Cummins Power Generation, Inc. All rights reserved.



HW-MY35 FLUID SYSTEM

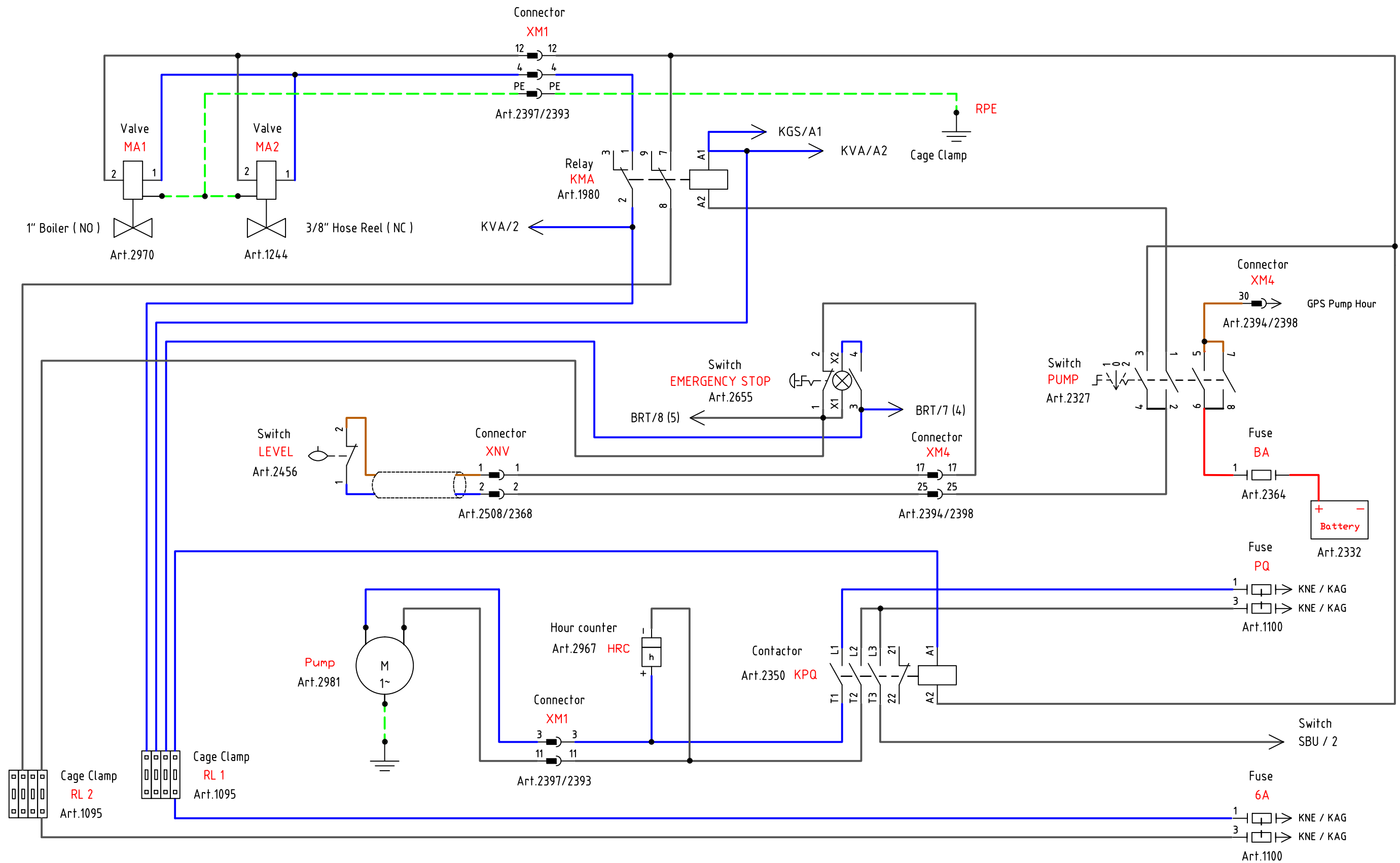



Tecnical Support Phone : +47 488 93 271
Heatwork Office Phone : +47 769 65 890

DRAWING REV

HW-MY35 BOILER SYSTEM

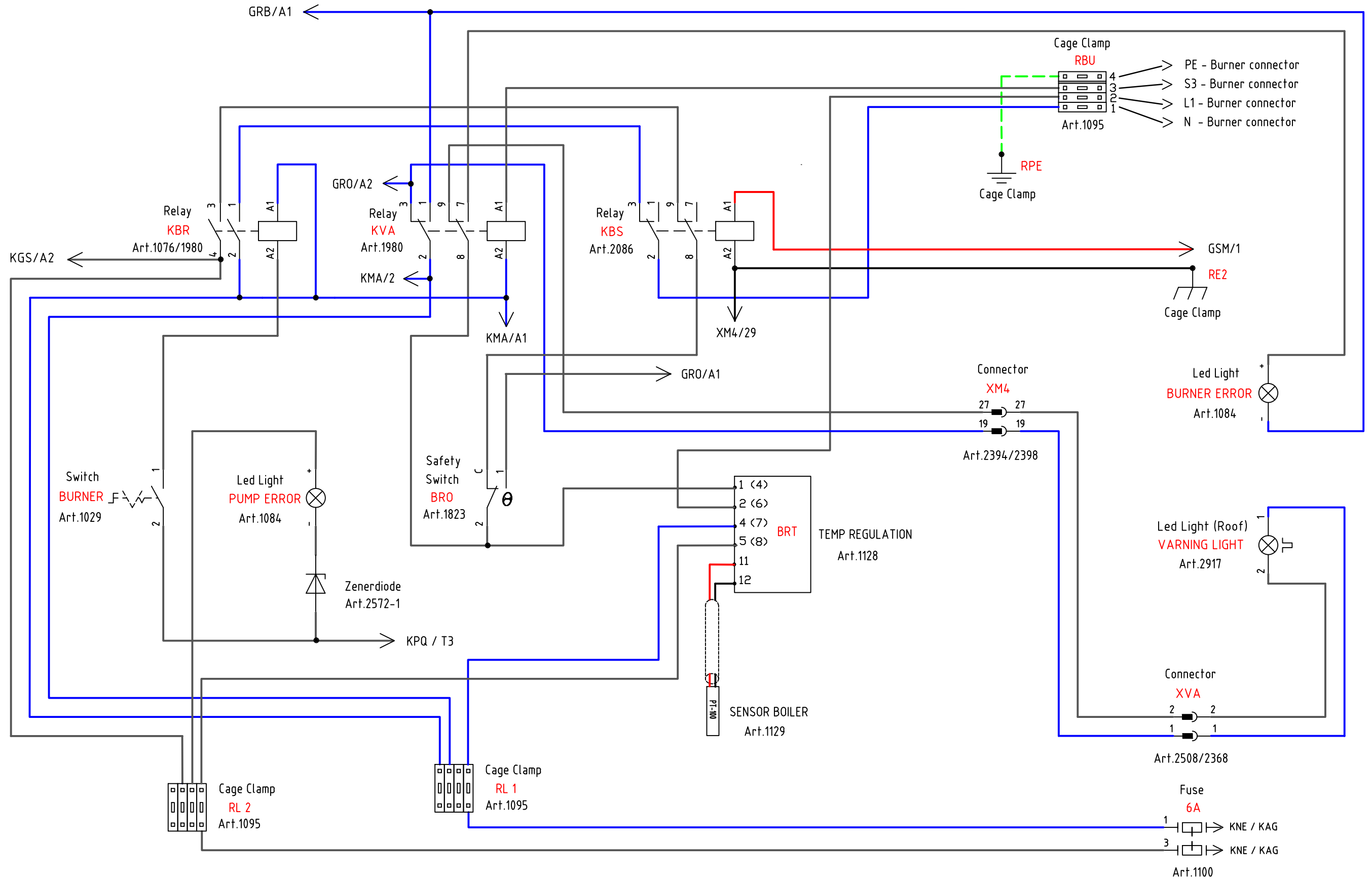

HW-MY35 AUTOSTART SYSTEM

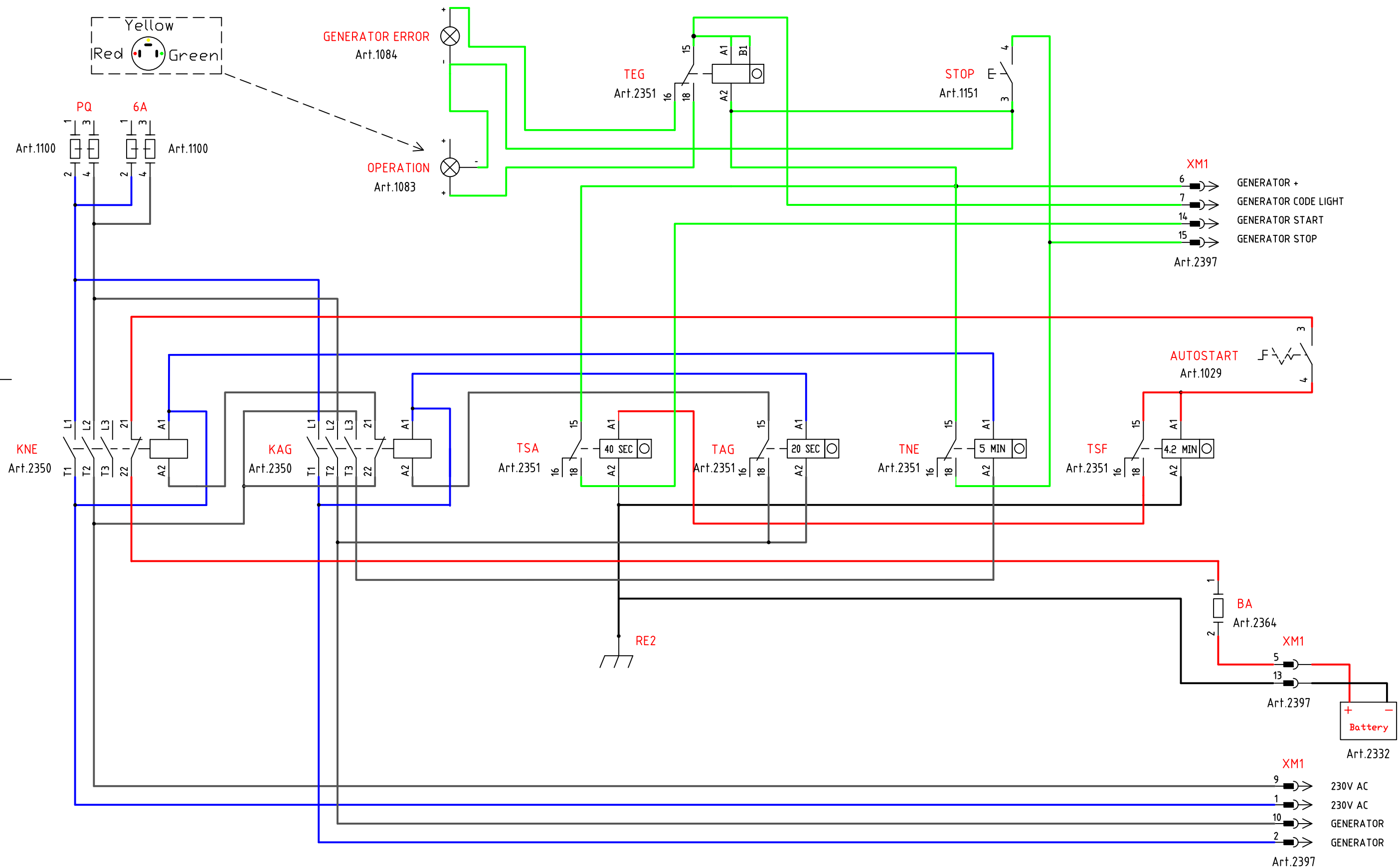

HW-1800/3600 FLUID SYSTEM

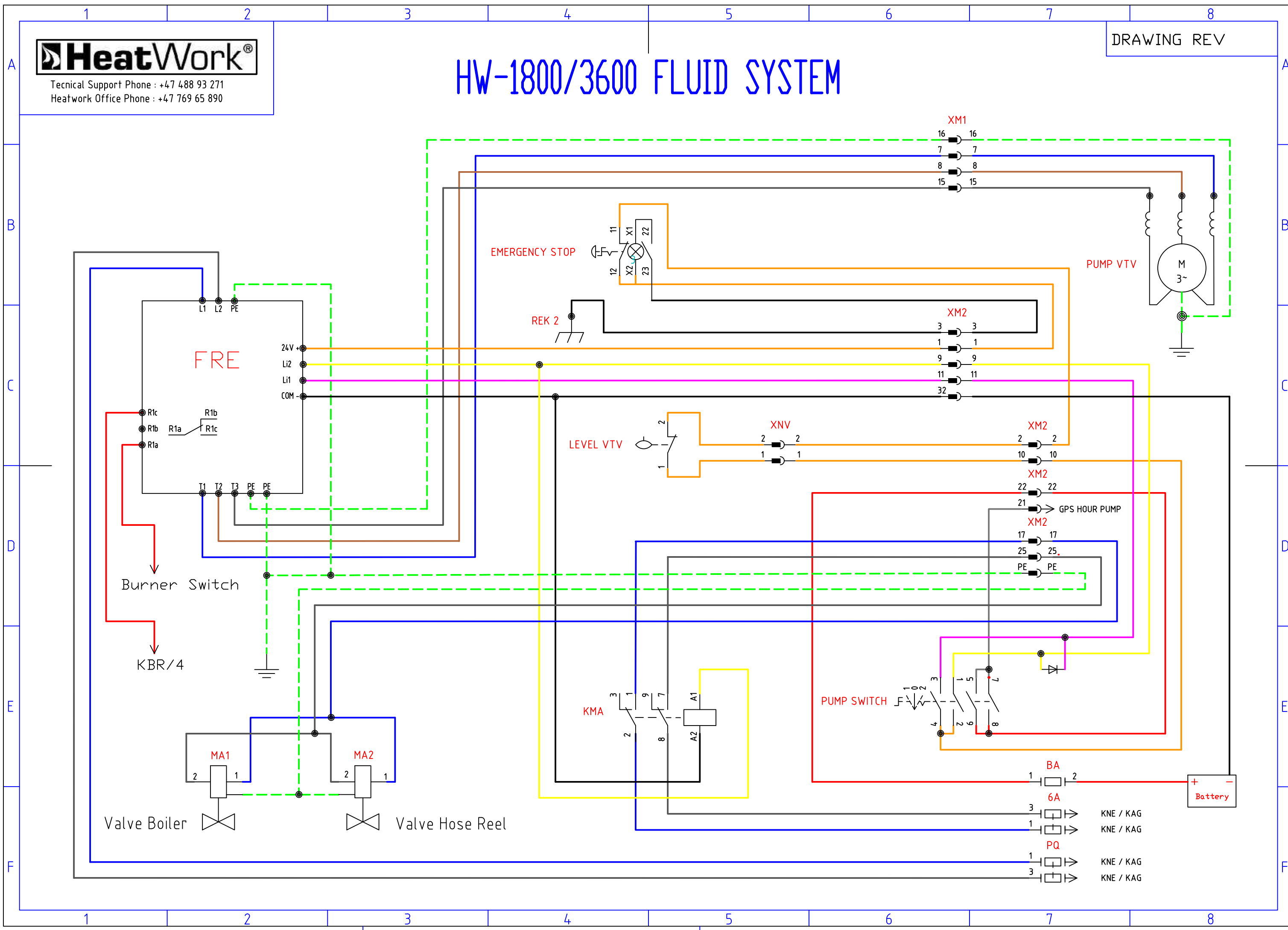

- BA 1 2
- 6A 3 1
- PQ 1 3
- KNE / KAG 1 3
- KNE / KAG 1 3

HW-1800/3600 BOILER SYSTEM

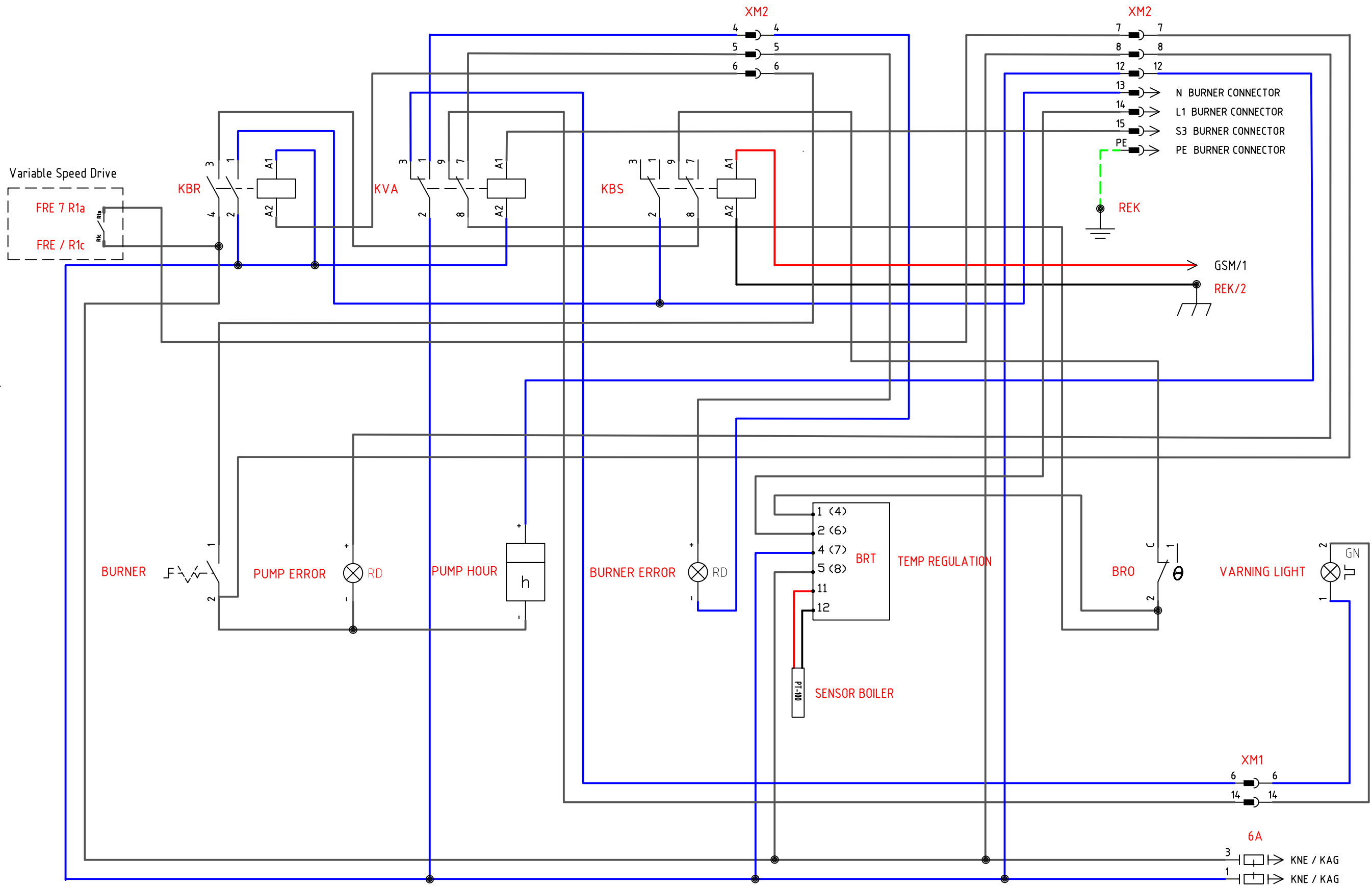



Technical Support Phone : +47 488 93 271
Heatwork Office Phone : +47 769 65 890

HW-1800/3600 AUTOSTART SYSTEM

DRAWING REV

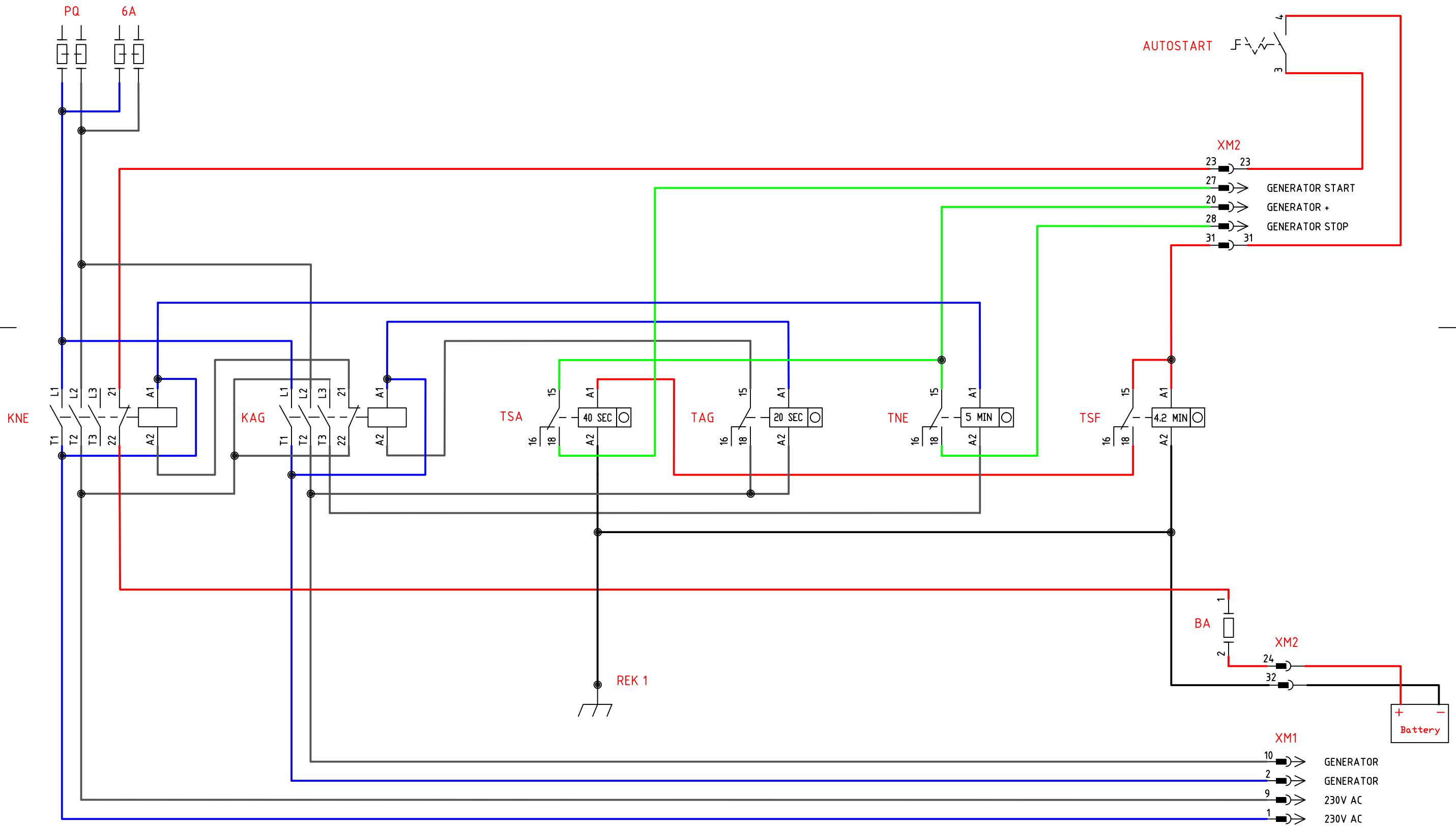



www.heatwork.com



Skarvenesveien 6
P.O. Box 353
N-8501 Narvik
NORWAY

post@heatwork.com

Telephone: (+47) 76 96 58 90

Service: (+47) 488 93 271