

DINO[®] 105_{TL}

OPERATING INSTRUCTIONS



Manufacturer:

DINOLift
UP TO THE JOB

Raikkolantie 145

FI-32210 LOIMAA

Tel. +358 20 1772 400

info@dinolift.com

www.dinolift.com

Dealer:



ORIGINAL OPERATING INSTRUCTIONS

Valid from serial number 10004 →

TABLE OF CONTENTS

OPERATING AND SAFETY INSTRUCTIONS	6
1 EU DECLARATION OF CONFORMITY	6
2 REACH DIAGRAM	7
3 DIMENSION DRAWING	8
4 TECHNICAL SPECIFICATION	9
4.1 EXAMPLE OF THE MACHINE'S NAMEPLATE	9
4.2 GENERAL DESCRIPTION OF THE MACHINE.....	10
4.3 DESCRIPTION OF THE MACHINE'S INTENDED USE	11
5 GENERAL SAFETY REGULATIONS	11
5.1 INSTRUCTIONS FOR SAFE OPERATION!	14
6 INSPECTIONS	15
7 WORKSITE INSPECTION	16
8 OPERATION OF THE SAFETY DEVICES	17
9 OPERATING CONTROLS	18
9.1 OPERATING CONTROLS IN THE CHASSIS CONTROL CENTRE.....	18
9.2 OPERATING CONTROLS OF OUTRIGGERS	19
9.3 OPERATING CONTROLS IN THE PLATFORM CONTROL CENTRE UCB.....	20
10 MEASURES TO BE TAKEN IN THE CASE OF EMERGENCY/IF THE LIFT IS AT RISK OF LOSING ITS STABILITY	21
11 STARTING UP	22
11.1 DRIVING FROM THE LCB CENTRE (CHASSIS CONTROL CENTRE).....	25
11.2 DRIVING FROM THE UCB CENTRE (PLATFORM CONTROL CENTRE).....	26
12 EMERGENCY DESCENT SYSTEM	29
13 DRIVING DEVICE (OPTION) VIRHE. KIRJANMERKKIÄ EI OLE MÄÄRITETTY.	
13.1 USING THE DRIVING DEVICE (OPTION) . VIRHE. KIRJANMERKKIÄ EI OLE MÄÄRITETTY.	
14 SPECIAL INSTRUCTIONS FOR WINTER USE	32
15 MEASURES TO BE TAKEN AT THE END OF THE WORKING DAY	32
16 PREPARING THE LIFT FOR TRANSPORT	32
17 CONNECTION TO THE TOWING VEHICLE	33
INSTRUCTIONS FOR SERVICE AND MAINTENANCE	34
18 GENERAL SERVICE INSTRUCTIONS	34
18.1 LIFTING.....	34
18.2 SERVICE AND INSPECTION INSTRUCTIONS.....	35

18.3	LUBRICATION PLAN.....	36
18.4	LONG-TERM STORAGE	37
18.5	LOAD HOLDING AND LOAD REGULATION VALVES	38
18.6	WHEEL BRAKES AND BEARINGS	40
18.7	LEVELLING SYSTEM OF THE PLATFORM.....	41
18.8	REGULAR SERVICING	42
18.9	SCHEDULE FOR REGULAR SERVICING.....	42
18.9.1	Clean the lift thoroughly before the service.....	42
18.9.2	Change the hydraulic oil and replace the filter	43
18.9.3	Check the hydraulic hoses and pipes	43
18.9.4	Check the operation of the swing limiter	44
18.9.5	Inspect joints of the support outrigger	44
18.9.6	Inspect the cylinders, and lubricate the joint bearings.....	45
18.9.7	Inspecting the boom and the frame	45
18.9.8	Check the overrun.....	46
18.9.9	Inspection of the axle and the suspension	46
18.9.10	Inspecting the safety devices	46
18.9.11	Operation of the safety devices while they are controlled from the chassis control panel	47
18.9.12	Measuring pressure of the hydraulic system.....	47
18.9.13	Check the operating controls on the platform	48
18.9.14	Warning stickers and adhesive tapes	48
18.9.15	Inspect the brakes and the driving device.....	48
18.9.16	Traffic lighting.....	48
18.9.17	Anti-corrosion treatment.....	48
18.9.18	Test-run	49
18.9.19	Draw up an inspection protocol.....	49
19	INSPECTION INSTRUCTIONS.....	50
19.1	FIRST INSPECTION.....	50
19.1.1	SAMPLE OF INSPECTION PROTOCOL FOR THE ACCESS PLATFORM... 51	51
19.2	DAILY INSPECTION (START-UP INSPECTION)	53
19.3	MONTHLY INSPECTION (MAINTENANCE INSPECTION).....	54
19.4	ANNUAL INSPECTION (REGULAR INSPECTION).....	54
19.5	EXTRAORDINARY INSPECTION	58
19.6	TEST LOADING INSTRUCTIONS FOR REGULAR INSPECTION	59
20	FAULT FINDING	60
21	GENERAL INFORMATION OF HYDRAULICS.....	66
21.1	NOTES	67
22	ELECTRIC COMPONENTS 105TL 10001 →	68
22.1	CHASSIS CONTROL CENTRE (LCB), RELAYS	68
22.2	CHASSIS CONTROL CENTRE (LCB), SWITCHES.....	68
22.3	CHASSIS CONTROL CENTRE (LCB), OTHER ITEMS	69
22.4	PLATFORM CONTROL CENTRE (UCB), SWITCHES	69
22.5	PLATFORM CONTROL CENTRE (UCB), OTHER ITEMS.....	70
22.6	LIMIT SWITCHES.....	70
22.7	OTHER MARKINGS	70
23	ELECTRIC DIAGRAM 105TL 10001 →.....	71
24	HYDRAULIC DIAGRAM 10001→.....	78



24.1 NOTES 79

OPERATING AND SAFETY INSTRUCTIONS

1 EU Declaration of Conformity

EU Declaration of Conformity

Manufacturer:

**Dinolift Oy
Raikkolantie 145
FI-32210 Loimaa,**

which has authorised the Chief Engineer Mr. Seppo Kopu, Dinolift Oy, Raikkolantie 145, 32210 Loimaa, FINLAND, to draw up the Technical Construction File,

declares that

DINO 105TL Access Platform no YGC 265RXT X X XXXXX

complies with the provisions of the Machine Directive **2006/42/EC** and its amendments as well as the national decree (**VNA 400/2008**), through which they have been brought into effect as well as the regulations of the Low Voltage Directive **2000/14/EC** and the EMC Directive **2004/108/EC**.

To the assessment procedure of conformity has been applied: 2000/14/EC, Annex V: Internal control of production.

Notified body no. 0537,

VTT
P.O.Box 1300
FI-33101 Tampere
FINLAND

has granted the certificate no. VTT XXX / XX / XX

In designing the machine, the following harmonised standards have been applied:

SFS-EN 280/A1+A2; SFS-EN 60204-1/A1

Loimaa
(place)

21.10.2014
(date)

(signature)

Seppo Kopu
Chief Engineer

(name in block letters, position)



2 REACH DIAGRAM

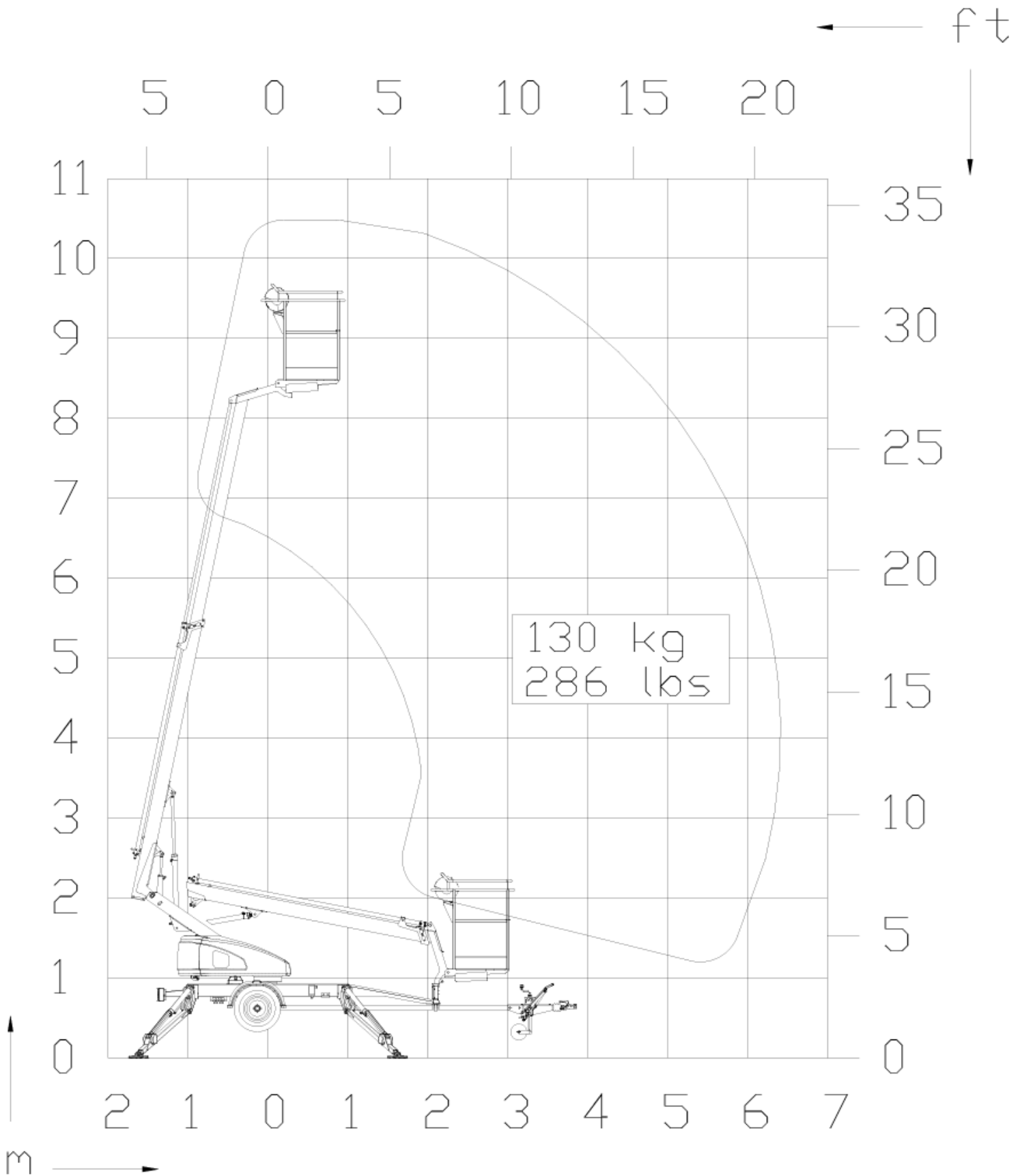

3 DIMENSION DRAWING

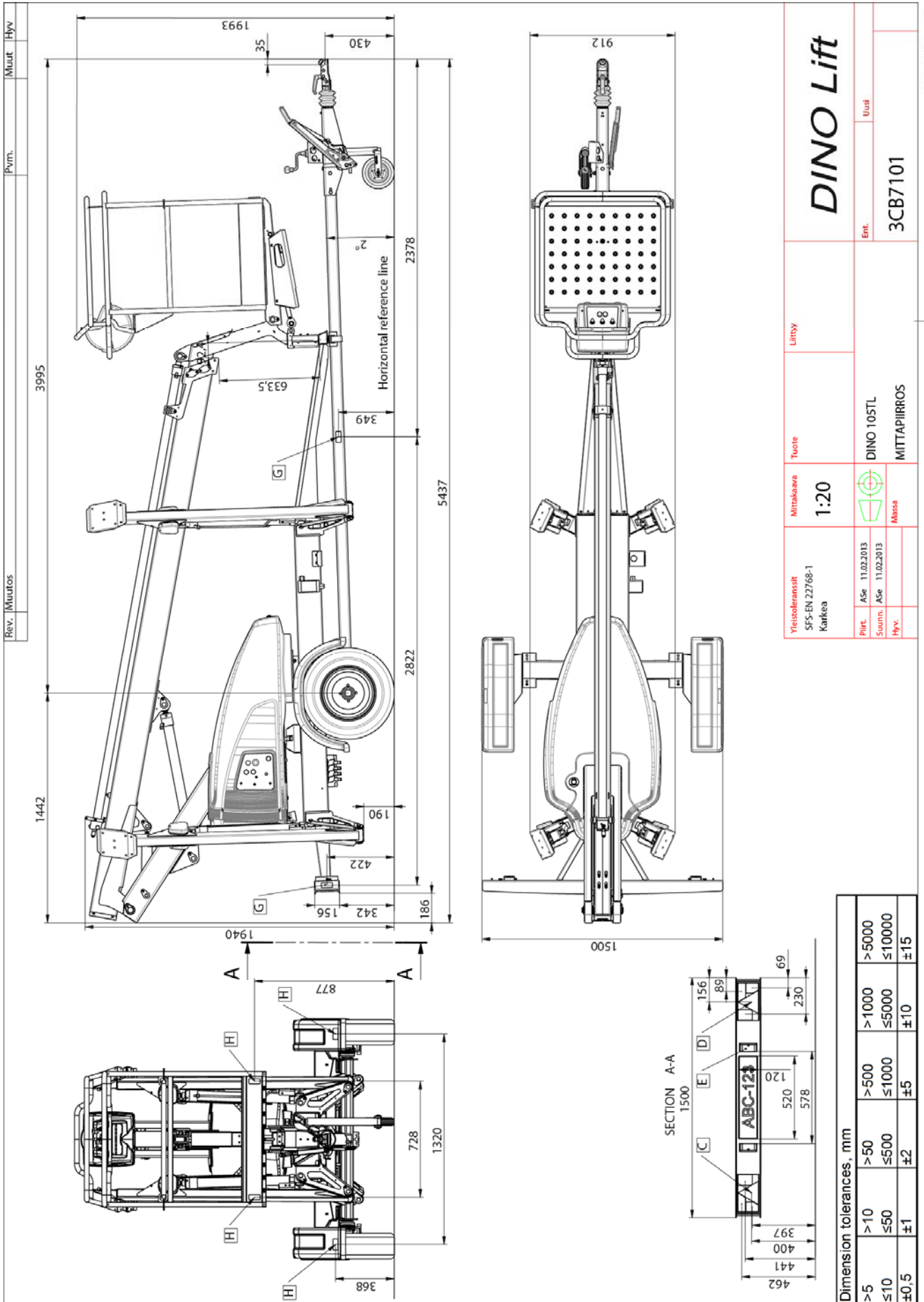

4 TECHNICAL SPECIFICATION

Max. working height	10.5 m
Max. platform height	8.5 m
Max. outreach	6.5 m
Boom rotation	+/- 355°
Turn area diagram	refer to the reach
Support width	3.57 m
Transport width	1.5 m
Transport length	5.44 m
Transport height	1.99 m
Weight	950 kg
Max. allowed load on platform	130 kg
Max. number of persons + additional load	1 person + 50 kg
Max. allowed sideways load (caused by persons)	200 N
Max. lateral inclination (chassis)	±0,3°
Max. wind speed during operation	12,5 m/s
Min. ambient temperature when working	-20 °C
Max. support force on the outriggers	7500 N
Platform size	0.85 m x 0.7 m
Gradeability using the driving device (optional)	15 %
Power supply:	230V/ 50Hz/ 10A
Sound pressure level	Under 70 dB
Socket outlets on the platform	2 x 230V/ 50Hz/ 10A

4.1 Example of the machine's nameplate

Type	DINO	Manufacturer	DINO Lift®
Year of manufacture		Address of manufacturer	Raikkolantie 145 32210 Loimaa FINLAND
Number of manufacture			
Weight kg		Max. load	130 kg
Max. load of persons	1	Additional load	50 kg
Max. side force	200 N	Max. inclination of chassis	0,3°
Voltage	230 V	Frequency	50 Hz
Min. operating temperature	-20 °C	Max. wind force	12,5 m/s

54.1329

CE



4.2 General description of the machine

The denominations of the machine's essential parts and concepts, which are used later in these instructions, are described on this page.

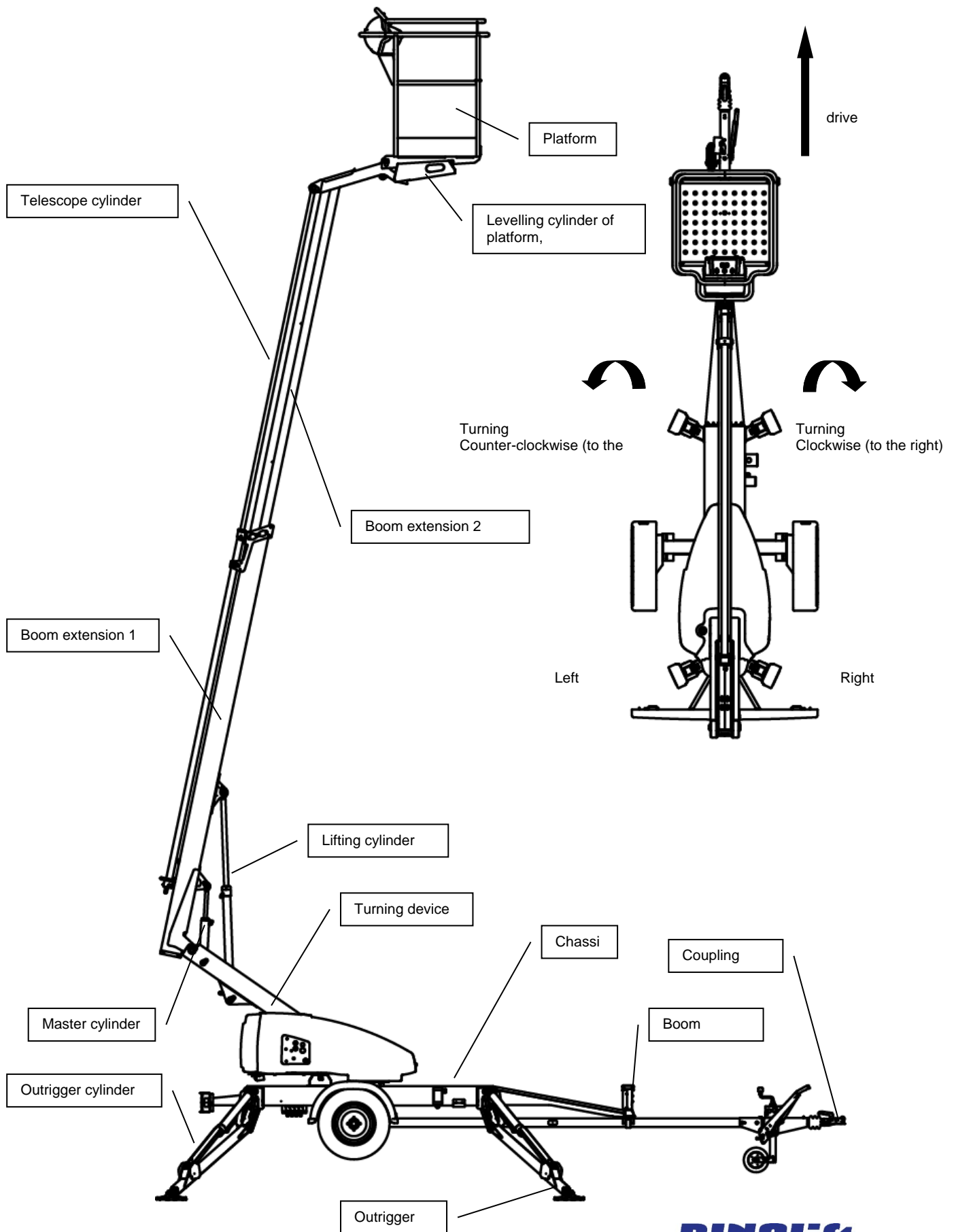

4.3 Description of the machine's intended use

The Access Platform is exclusively intended for transferring people and tools, as well as for acting as a work platform to the limit of its load-bearing capacity and reach (refer to the table of Technical Specifications and Reach Diagram).

The intended use also covers:

- Following all the instructions in the Operating Instructions.
- Performance of the inspections and maintenance operations.

5 GENERAL SAFETY REGULATIONS



Make yourself familiar with these operating instructions before using the lift!

- Keep these operating instructions in the place reserved for them.
- Make sure that all users of the lift are familiar with these instructions.
- Advise new users and strictly follow all instructions given by the manufacturer.
- Make sure you clearly understand all instructions relating to the operational safety of the lift.

Always use chocks under the wheels when disconnecting the lift from the car.

Only specially trained personnel with authorisation in writing from their employer and who have good familiarity with the device and are at least 18-years old are allowed to operate the lift

- The max. allowed load on the platform is one (1) person and at maximum fifty (50) kg of additional load, however, the total load must not exceed one hundred thirty (130) kg.
- The platform may only be operated when the chassis is well supported and the wheels are off the ground.
- The load-bearing capacity and the gradient of the ground must be taken into account when supporting the chassis.
- Additional support plates of adequate size must be used under the outriggers when working on soft ground. Only use such additional support plates on which the metallic outriggers will not slide.

The lift may only be moved in the transport position. No persons or load are allowed on the platform during the transportation.

The weather conditions, such as wind, visibility and rain, must always be taken into account so that these factors will not adversely affect the safe performance of the lifting operations.

The lift must not be used if the temperature drops below -20°C or the wind speed exceeds 12.5 m/s



USE THE SAFETY HARNESS!



Connecting points for the safety harness.

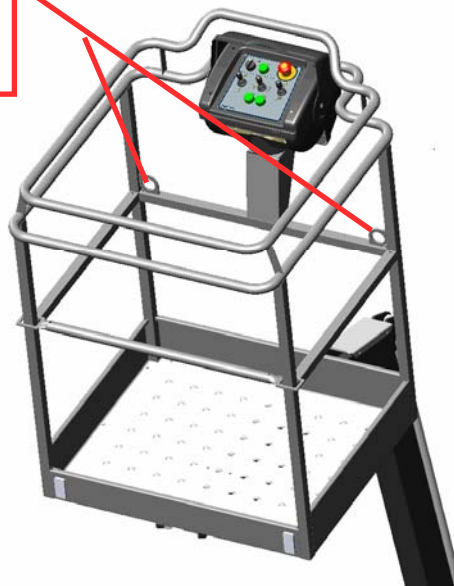

Do not use ladders, steps or other similar equipment on the platform.

Never throw any objects from the platform.

The lift must not be used for transferring goods or persons between different floors or working levels.

Always make sure before lowering the platform that the area on the underside is clear of any obstructions.

Avoid damaging the platform by lowering it on the ground or bringing it in contact with any structures.

When working in busy areas the operating range of the lift must be clearly marked by using either warning lights or fencing.

Also observe the regulations of the Road Traffic Act.

Beware of the live aerial power lines in the area – observe the minimum safety distances:



Keep the lift free of any dirt which may impair safe operation and impede the inspection of the structures.

The device must be serviced and inspected regularly.

Only skilled persons familiar with servicing and repair instructions are allowed to carry out servicing and repair work.

It is strictly prohibited to use a lift which is out of order.

The operator must be given instructions and consent from the manufacturer for all such specific work methods or conditions that the manufacturer has not explicitly defined.



Voltage	Min. distance below (m)	Min. distance at the side (m)
100 – 400 V hanging spiral cable	0.5	0.5
100 – 400 V open-wire cable	2	2
6 – 45 kV	2	3
110 kV	3	5
220 kV	4	5

The device must neither be altered without the manufacturer's consent nor be used under conditions which do not meet the requirements set by the manufacturer.



5.1

5.1 Instructions for safe operation!



- Use a safety harness while on the platform.
- Never load the platform while in the upper position.
- The lift must not be used when the temperature is below -20°C and the wind speed exceeds 12.5 m/s.
- Beware of live power lines within the work area.
- The lift **MUST NOT** be used as a crane.
- Always ensure the load-bearing capacity of the ground.
- Ensure the unobstructed range of movement before operating the outriggers.
- While in the support position, ensure that the wheels are off the ground.
- Always verify the horizontal position of the machine.
- Ensure that the outriggers cannot slide while on a gradient.
- Always ensure that the work area is clear of outsiders. Danger of getting squeezed between rotating and fixed structures.
- Stepping on or off the platform in motion is prohibited.
- The maximum-allowed gradient during transfers is 5°. During transfer in rough terrain, try to stay above the machine.
- While operating the boom from the control panel on the turning device, beware of getting pressed against the outriggers or other structures that do not turn with the boom.
- When the boom is in its lowest positions, make sure it cannot clash during rotation with structures that do not turn with the boom.
- Before operating, always ensure that the safety devices and the emergency descent system are in working order.
- Do not take tools/material of large surface area onto the platform. The increase in wind load may jeopardize the stability of the device.
- Always keep the lift free from dirt, snow and ice.
- Ensure that the lift is inspected and serviced, before use.
- Never use a defective lift.

- **Never use a lift alone. Make sure that there is always someone on the ground, who can call for help in case of an emergency.**

6 INSPECTIONS

The lift must be subjected to a **start-up inspection** before it is used for the first time and before starting it up the first time after a major repair or modification work.

The lift must be subjected to a thorough **periodic inspection with related test drive** at intervals of year.

The lift must be subjected to a thorough **periodic inspection with test drive** at intervals of four years.

In connection with the periodic inspection the lift must be subjected to a **non-destructive inspection/inspection disassembled** in general at intervals of ten (10) years from the start-up date.

In addition, the lift must be **inspected** to the extent applicable after any exceptional situation

For the inspection must be assigned an **expert inspection body** with documented evidence of competence or an **expert with documented evidence** of competence.

A **protocol** must be drawn up of the executed inspections. The protocols of the start-up and periodic inspections must be kept with the lift or its immediate proximity for at least five years.

Carry out the inspections regularly basis throughout the service life of the lift.

The inspection must be carried out within twelve (12) months off the first or previous inspection.

If the lift is used under extreme conditions, intervals between the inspections shall be reduced.

The overall operating condition of the lift as well as the condition of the safety-related control devices shall be established in the regular inspections. Particular attention shall be paid to changes which affect the operational safety.

In connection with the regular inspection, it shall be established to what extent the lessons and practical experience gained from the previous inspection can be implemented for even better safety.

Regular inspections and service measures are described more thoroughly in the chapter "Service- and maintenance".

7 WORKSITE INSPECTION

1. General information

- Is the lift suited for the intended job?
- Is the performance of the lift sufficient for the job? (reach, loadability etc.)
- Is the position of the lift safe?
- Is the lighting on the worksite sufficient?

2. Documents

- Are the Operation and Service Instructions for this lift present? (Manufacturer's instructions)
- Are inspections and servicing carried out in accordance with the instructions and have the defects affecting the safety been checked as repaired? (Inspection protocols)

3. Structure (Visual inspection and operational test)

- General condition of the lift
- Operation and protection of the controls
- Emergency stop, signal horn and limit switches
- Electrical appliances and wiring
- Oil leaks
- Load markings and signs

4. Operator

- Is the operator old enough?
- Has the operator received the required training?

5. Special issues on the worksite

- Are there any additional regulations relevant to the worksite or the work?



8 OPERATION OF THE SAFETY DEVICES

1. Outriggers

The safety limit switch **RK3** prevents the operation of the outriggers and the driving device when the boom does not rest on the transport support. The switch is located on the tow-bar at the transport support.

2. Lifting of the boom

All the lift's support outriggers must be in the support position before the boom is lifted. Make sure that the wheels are off the ground. The safety limit switches **RK11**, **RK12**, **RK13** and **RK14** are located on the support outriggers.

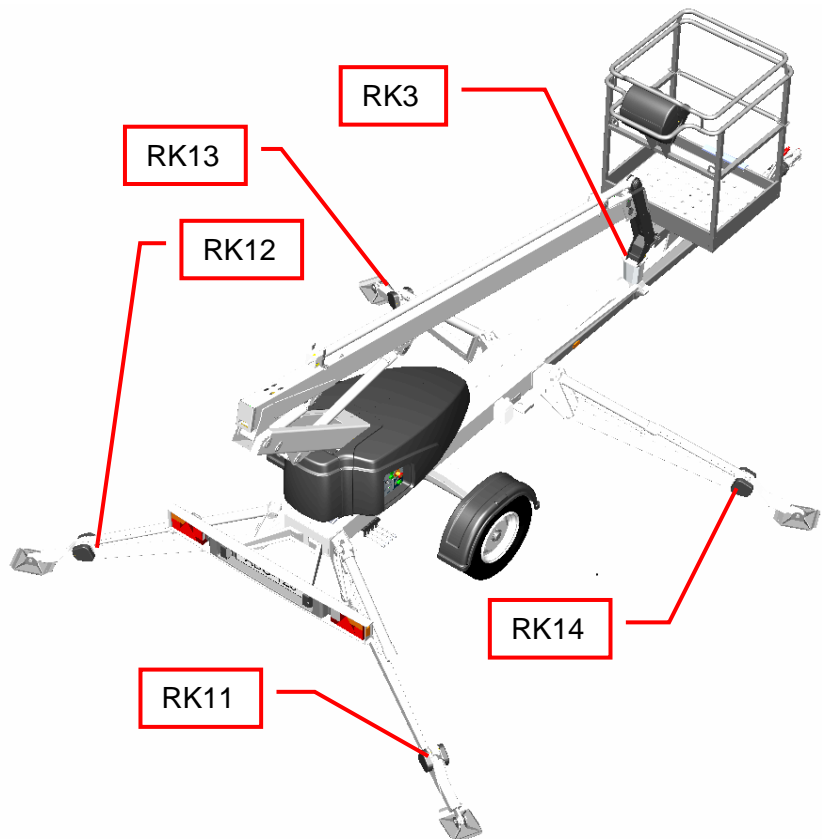

3. As the emergency stop button is depressed all movements stop and the power unit is turned off. The emergency stop pushbutton must be pulled up before starting the power unit.

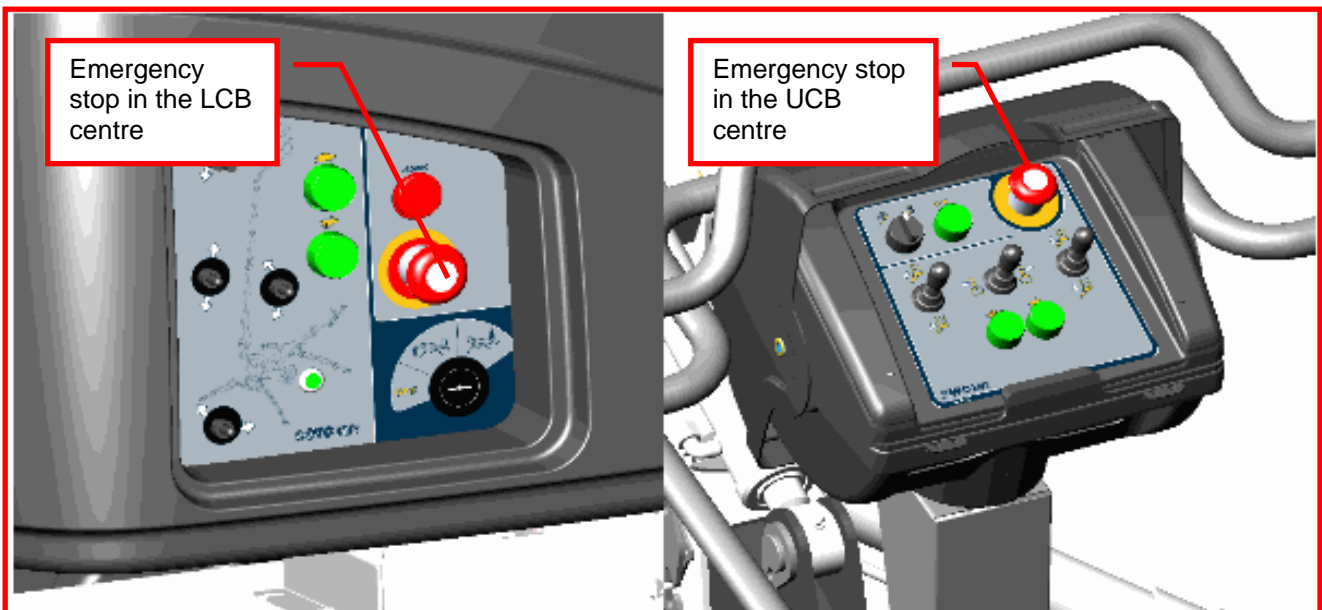

Check operation of the safety devices.





9 OPERATING CONTROLS

9.1 OPERATING CONTROLS IN THE CHASSIS CONTROL CENTRE

Q1.Selector switch	S3. High speed selection/start
Q1.1 OFF – power off	H3.Signal light for the limit switches for outriggers
Q1.2 LCB control centre – outriggers	S16. Lever for turning the boom system
Q1.3 UCB platform control centre	S17. Lever for lifting the boom system
S1. Emergency stop	S18. Lever for telescope movement
Vi. Power on – signal light	S20. Lever for platform inclination
S2.Low speed selection/start	

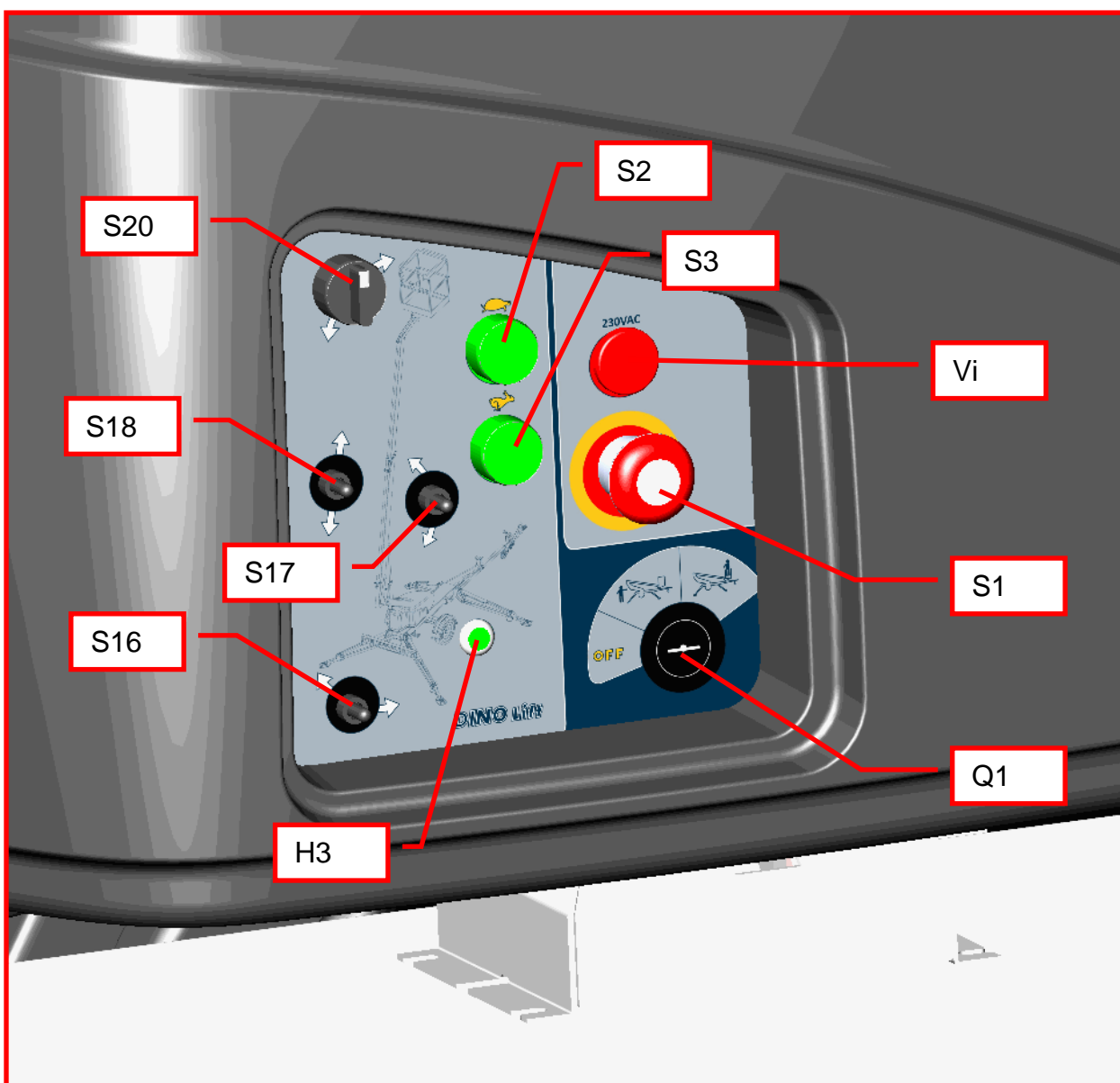

9.2 OPERATING CONTROLS OF OUTRIGGERS

1. Rear outrigger, right
2. Rear outrigger, left
3. Front outrigger, left
4. Front outrigger, right
5. Position indicator of chassis (water level)

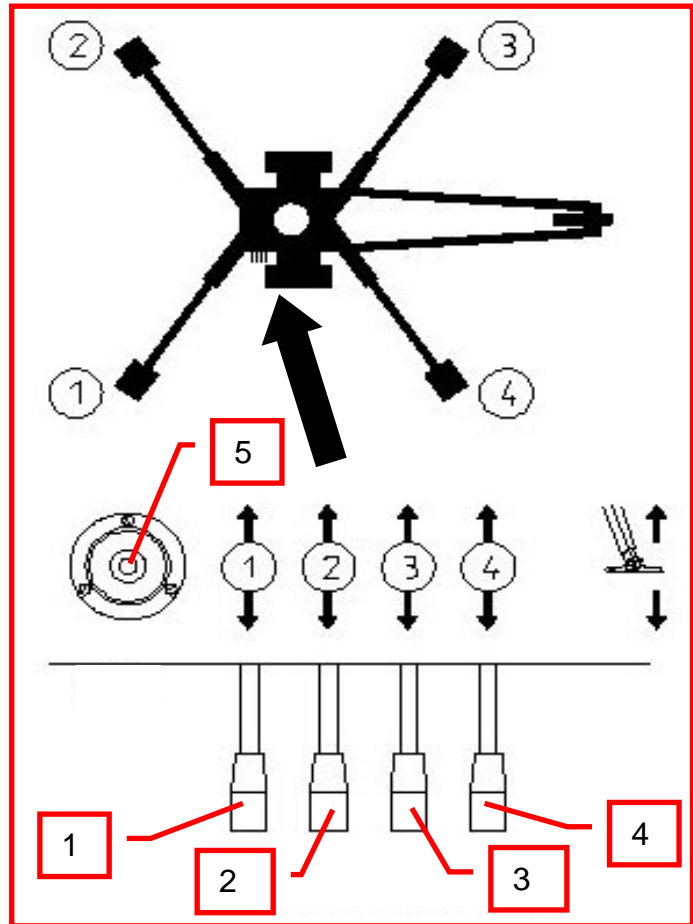



9.3 OPERATING CONTROLS IN THE PLATFORM CONTROL CENTRE UCB

S4. Emergency stop	S8. Lever for lifting the boom system
S5. Low speed selection/start	S9. Lever for telescope movement
S6. High speed selection/start	S10. Sound signal
S7. Lever for turning the boom system	S12. Lever for levelling the platform

Take away the key from the selector switch Q1 before you start operating the lift from the platform control centre UCB

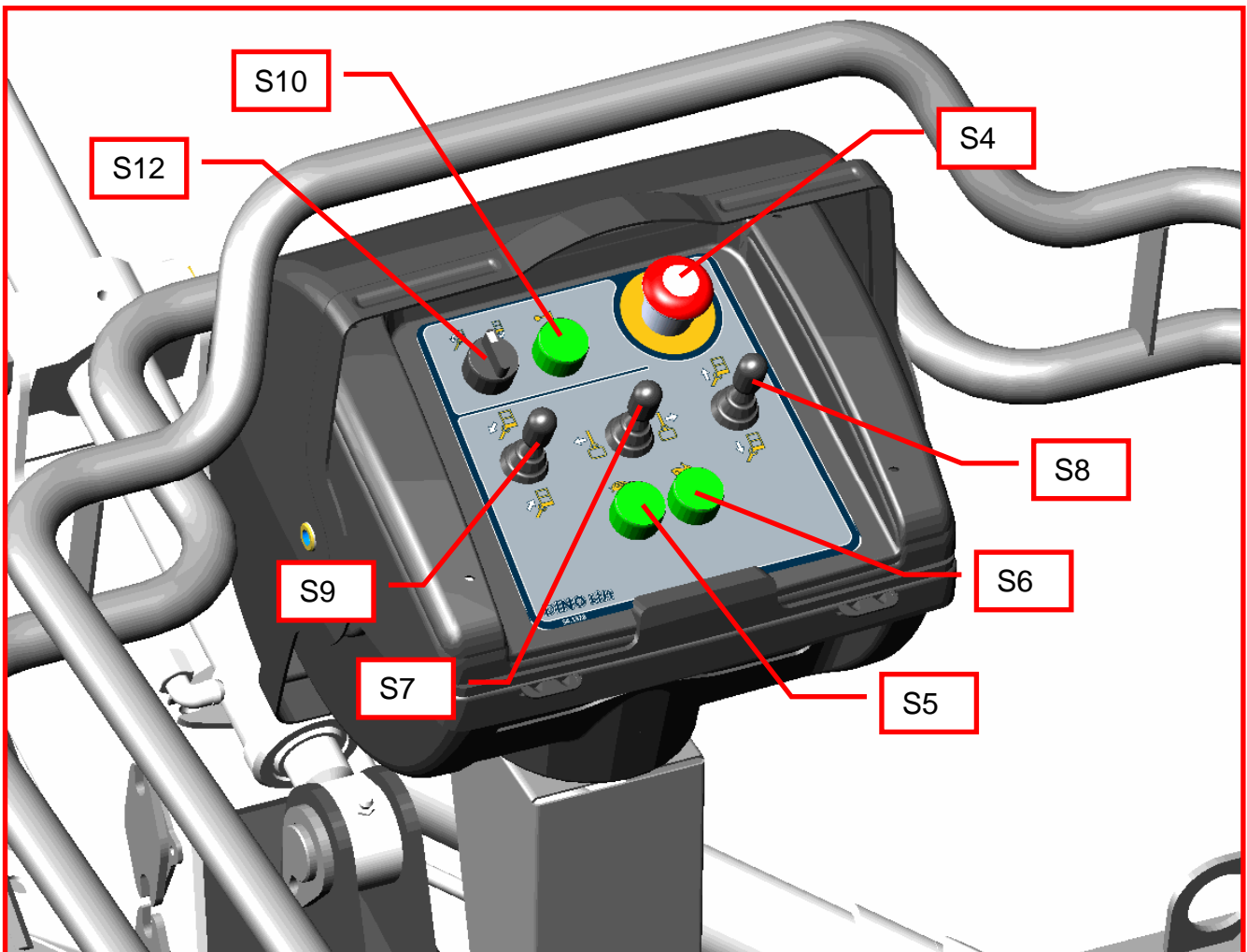

10 MEASURES TO BE TAKEN IN THE CASE OF EMERGENCY/IF THE LIFT IS AT RISK OF LOSING ITS STABILITY

Reduced stability can be caused by a fault in the lift, the wind or other lateral force, collapse of the standing base or negligence in providing sufficient support. In most cases one sign of reduced stability is the inclination of the lift.



WHEN AT RISK OF LOSING THE STABILITY

1. If there is time, try to find out the reason for the reduced stability and the direction of its effect. Warn other people on the worksite using the alarm signal.
2. If possible, reduce the load from the platform in a safe manner.
3. Reduce the outreach to the side by retracting the telescope. Avoid abrupt movements.
4. Turn the boom away from the danger zone, i.e. to a position where the stability of the lift is normal.
5. Lower the boom.

If the stability has been lost as a result of a fault in the lift, repair such a fault immediately.

Do not use the lift until the fault has been repaired and the condition of the lift has been verified.

IN CASE OF OVERLOADING

1. If there is time, try to find out the reason for the reduced stability and the direction of its effect. Warn other people on the worksite using the alarm signal.
2. If possible, reduce the load from the platform in a safe manner.
3. Reduce the outreach to the side by retracting the telescope.

IN CASE THE POWER SUPPLY IS INTERRUPTED (electric motor)

1. Lower the boom using the emergency descent system (see point “Emergency descent system”)
2. Establish the reason why the energy supply was interrupted.

IN CASE OF MALFUNCTION, WHEN EVEN THE EMERGENCY DESCENT SYSTEM IS NOT OPERATIONAL

1. If the emergency descent system does not operate, try to warn other personnel present on the site or call for help so that the power supply required for normal operation can be resumed or the lift can be made operational by some other means so that the person on the platform can be lowered safely down.

11 STARTING UP

1. Ground stability

- make sure that the ground is even and hard enough to support the lift in a steady level position.

Soil material	Density	Max. ground pressure P kg/cm ²
Gravel	High density	6
	Medium density	4
	Loose	2
Sand	High density	5
	Medium density	3
	Loose	1,5
Fine sand	High density	4
	Medium density	2
	Loose	1
Sand/ mud	High density (very hard to work)	1.00
	Medium density (hard to work)	0.50
	Loose (easily worked)	0.25

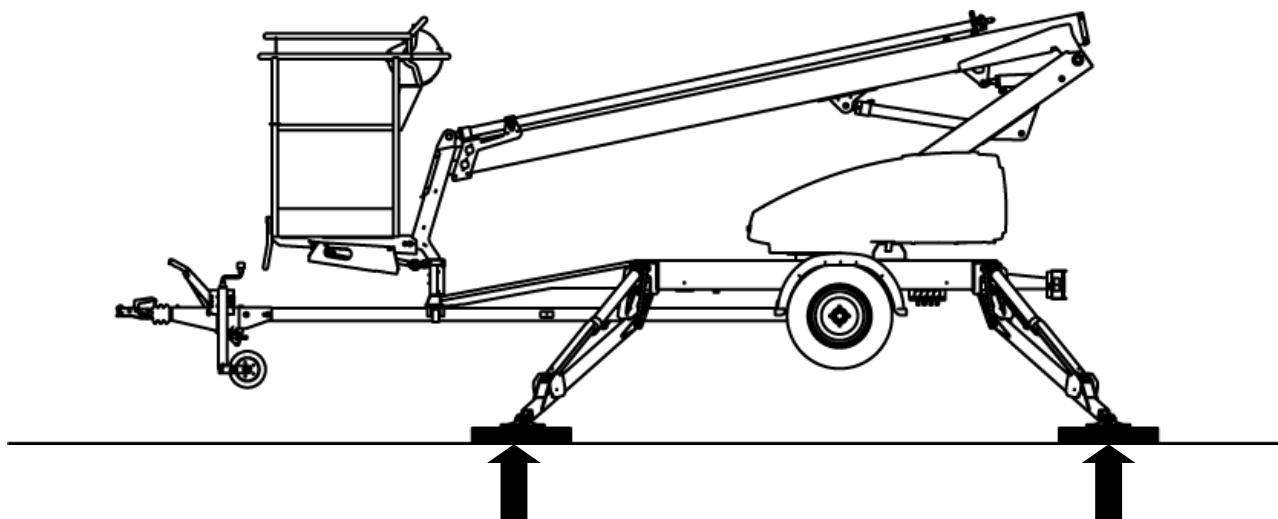

- if the ground is soft, use sufficiently large and sturdy additional plates under the support outriggers
- observe the effect of ice, possible rain and inclination of the surface on the support (the support outriggers must not slip on the surface)
- the operation is prohibited if the lift is not properly supported and in a level position (<math><0,3^\circ</math>)



2. Drive the lift to the inspected lifting site

- apply the parking brake
- disconnect the lift from the towing vehicle

3. Connection of power supply to the lift

- connect the mains cable to the power supply
- for maximum out of the electric motor the voltage must 230 VAC (-10 % +6 %), the frequency must be 50 Hz and rating of the fuse 10A (the length of the connecting cable has some effect)

4. Turn the selector switch (Q1) to position LCB – chassis centre

5. Start the engine from the pushbutton S2 or S3

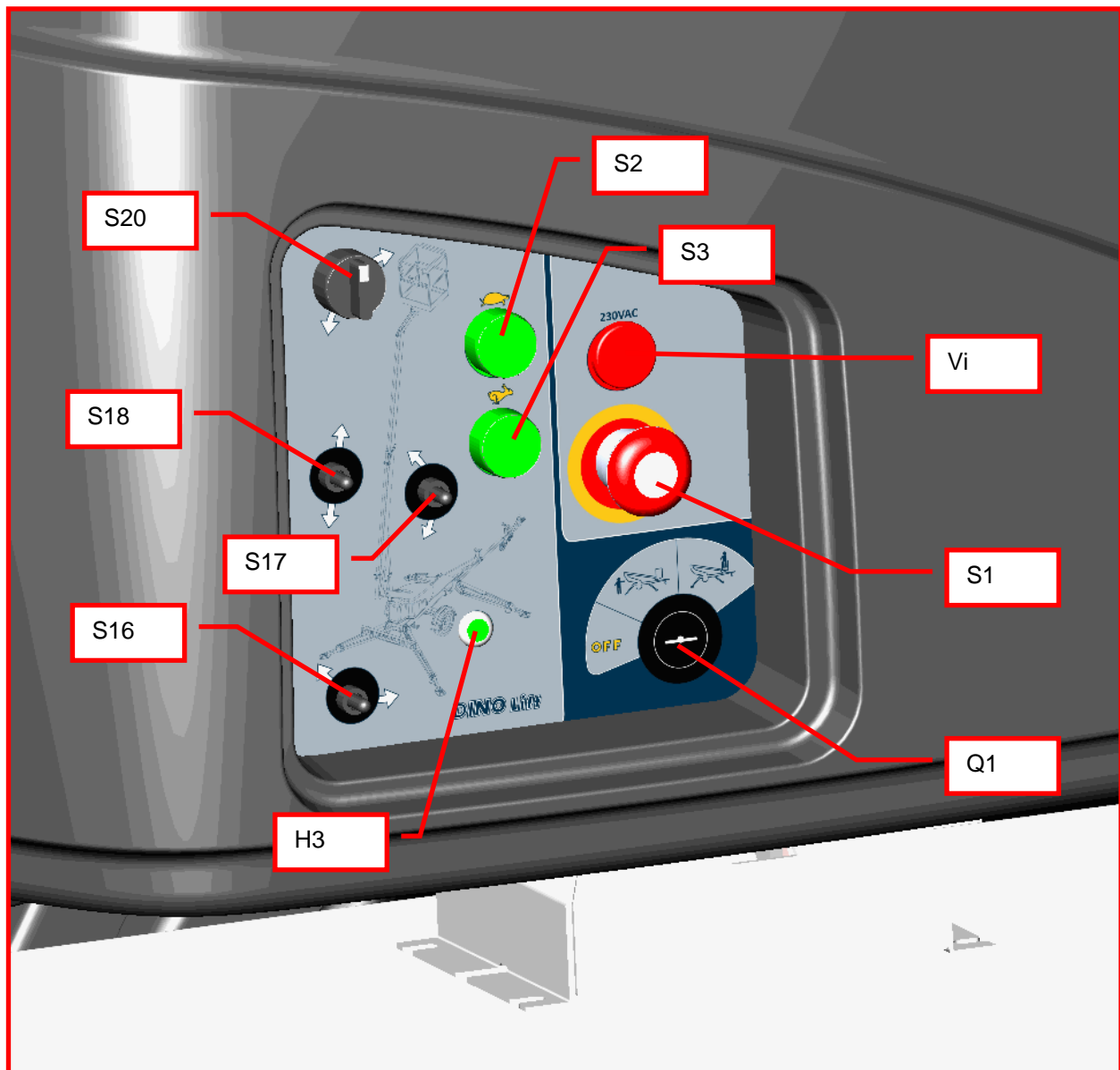



7. Lower the front outriggers 3 and 4 (on the tow-bar side) on the ground

8. Lower the rear outriggers 1 and 2

9. Level the chassis using the outriggers in accordance with the level gauge.

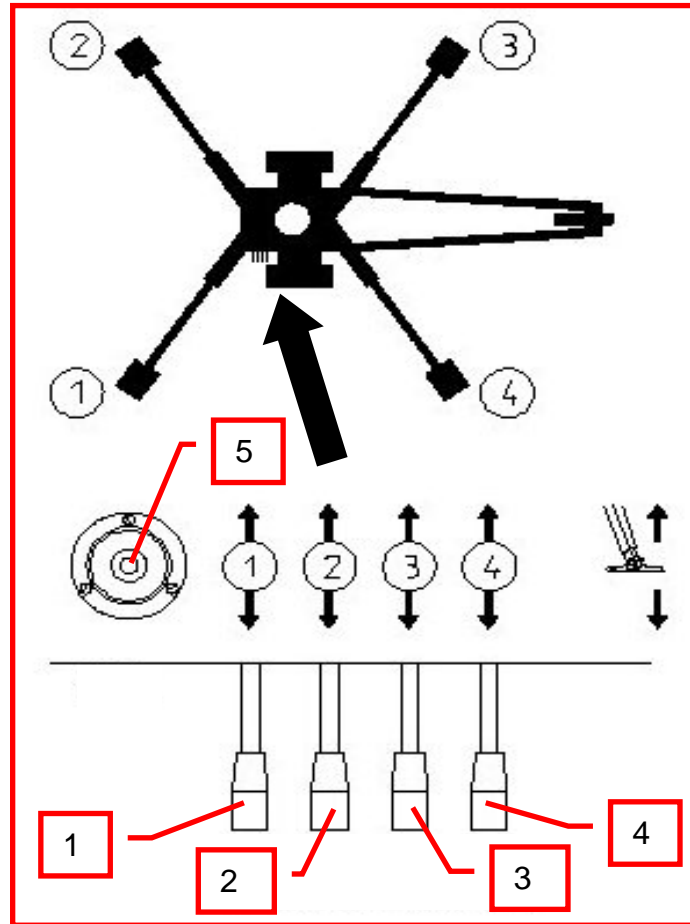

DO NOT LOAD THE TOW-BAR JOCKEY WHEEL



MAKE SURE THAT THE WHEELS ARE CLEARLY OFF THE GROUND

- the (green) signal light H3 on the chassis control centre LCB comes on when all the outriggers are in the support position, and the outrigger limit switch circuit is connected.
- make sure all outriggers are firmly supported on the ground

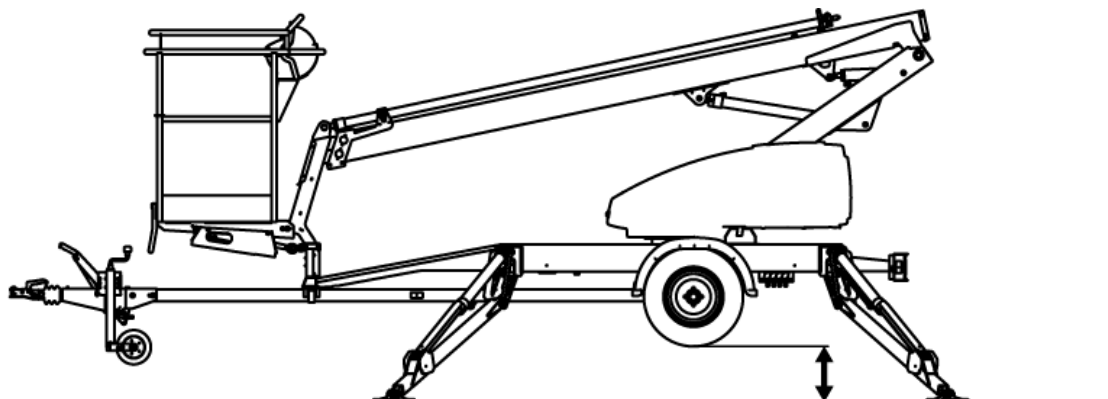

11.1 DRIVING FROM THE LCB CENTRE (CHASSIS CONTROL CENTRE)

10. Turn the selector switch (Q1) to position "LCB control centre"

- After having levelled the chassis, and brought the outriggers into the support position, you can operate the boom from the control levers S16, S17, S18 and the work platform from the lever S20. To operate the boom movements, you need to keep either the button S2 or S3 simultaneously depressed (selection of speed low/high).

Test the operation of the emergency descent system as follows:



1. Lift first the boom about 1–2 metres (lever S17) and then extend the telescope 1–2 metres (lever 8) keeping the emergency stop button depressed. The movement should now stop.
2. To retract the telescope, turn the selector lever to the left and pump with the hand pump until the telescope is fully retracted. The extension arm for the hand pump is under the bottom plate of the turning device (see picture below).
3. To lower the boom, turn the selector lever to the right and pump with the hand pump until the boom lowers onto the ground.
4. Pull up the emergency stop button.

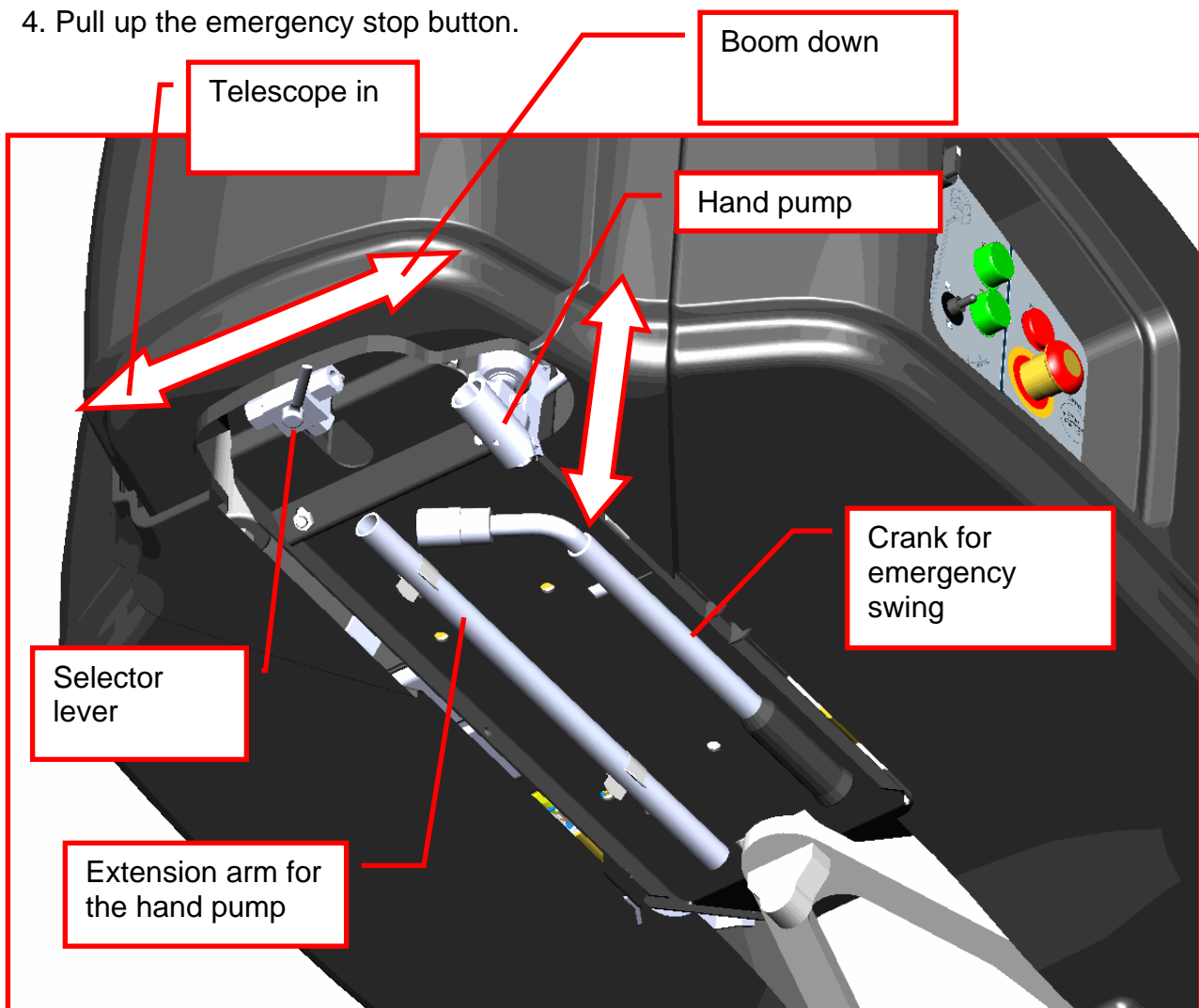

11.2 DRIVING FROM THE UCB CENTRE (PLATFORM CONTROL CENTRE)

11. Turn the selector switch (Q1) to position UCB (operating from the platform) and take away the key (see point "Operating controls in the chassis control panel LCB").

After having levelled the chassis, and brought all the outriggers correctly into the support position, you can operate the boom from the control levers S7, S8, S9 and the work platform from the lever S12.

To operate the boom movements, you need to keep either the button S5 or S6 simultaneously depressed (selection of speed low/high).

Only use the button S6 (high speed) with short boom and at low platform height.

Whenever possible, keep the boom short while lifting and lowering the platform.

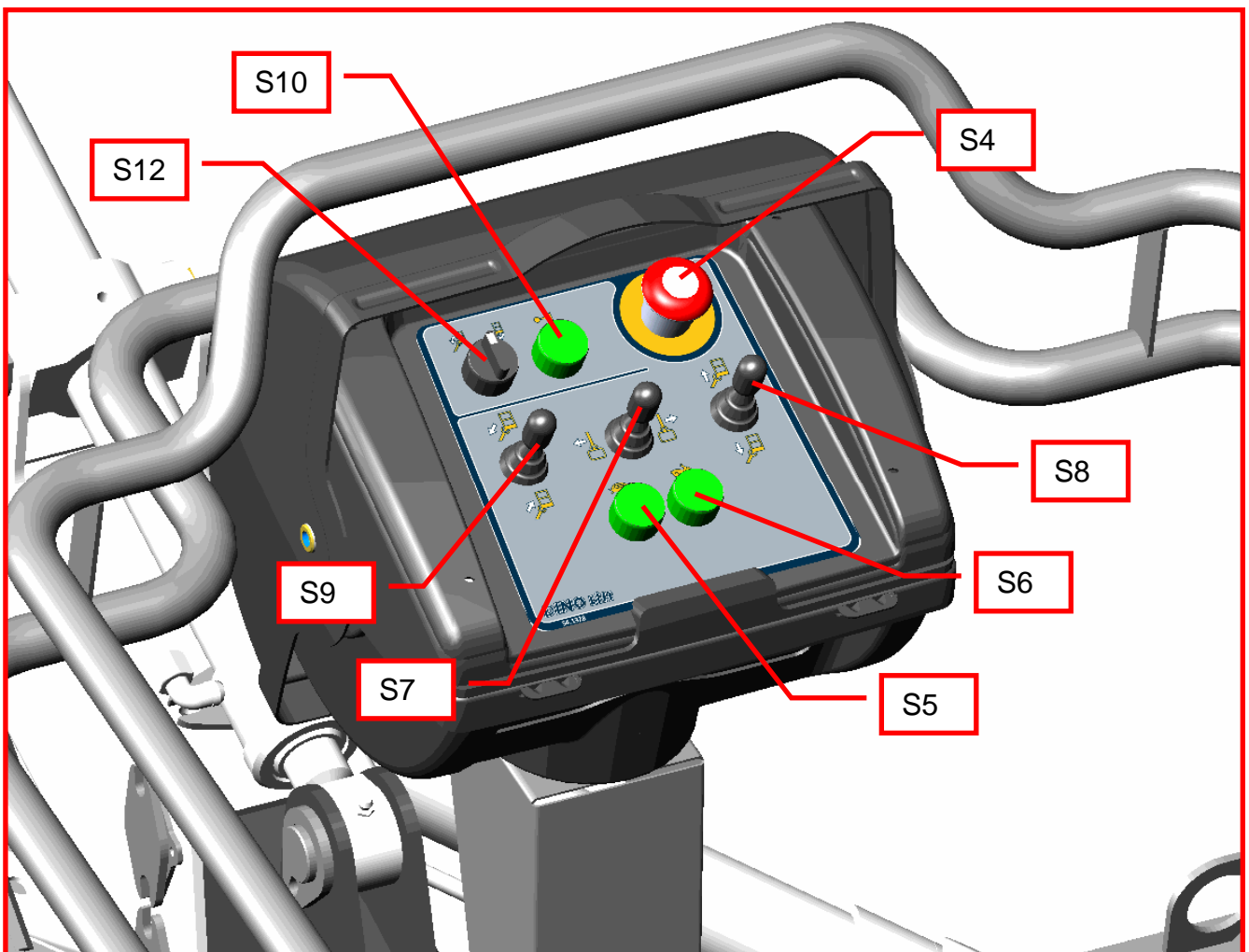

DO NOT DAMAGE THE TOW-BAR JOCKEY WHEEL

IF THE SAFETY DEVICES OR THE EMERGENCY DESCENT SYSTEM ARE NOT WORKING, HAVE THEM REPAIRED BEFORE OPERATING THE LIFT.



12. Refer to the item “Daily inspections” in the task list for servicing.

13. With the boom slightly lifted and the telescope extended, make sure that the platform does not lower by itself while the operating controls are not being used.

14. When working under cold weather conditions, let the engine run for a while without load to increase the hydraulic oil temperature. Start the operations by driving the movements carefully without load back and forth from the chassis control panel.

15. Move the platform to the work object

If several control levers are operated simultaneously, only the movement with the least resistance will operate.

NOTE!

Lowering the platform to transport position: Always retract the telescope completely before lowering the boom onto the transport support.



DO NOT TAKE ADDITIONAL LOAD IN THE UPPER POSITION!

16. When moving the platform, remember the following

- be careful of the high voltage power lines
- do not exceed the max. allowed lateral force (200N)
- do not touch open electric wires
- do not throw objects from the platform
- do not damage the lift
- do not take additional load in the upper position
- do not damage other devices
- do not load the platform vertically more than what is allowed

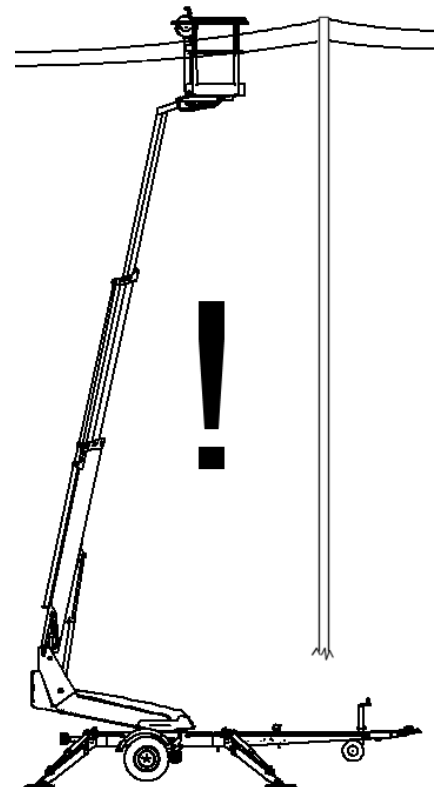

17. When leaving the lift

- drive the lift to a safe position, preferably to the transport position
- switch off the power unit

18. Adjustment of the platform position

From the chassis control panel LCB:

Carry out the levelling of the platform while the lift is in the support position (the outriggers on the ground). Adjust the platform position with the boom on a level. No persons allowed on the platform during adjustment.

The platform may be levelled from the chassis control centre LCB in the following way:

Turn the selector switch (Q1) to the position LCB – chassis centre. Depress the button (S2/S3), and simultaneously select the desired direction for the correction movement using the control lever (S20).

From the platform control panel UCB:

The platform may also be levelled from the platform control centre UCB in the following way:

Turn the selector switch (Q1) to the position UCB – platform centre. Depress the button (S5/S6), and simultaneously select the desired direction for the correction movement using the control lever (S12).

12 EMERGENCY DESCENT SYSTEM

Start by retracting the telescope completely, continue by lowering the boom and finally turn boom system.



the

Operation:

1. Retracting the telescope

To retract the telescope, turn the selector lever to the left and pump with the hand pump until the telescope is fully retracted. The extension arm for the hand pump is under the bottom plate of the turning device (see picture below).

2. Lowering the boom

To lower the boom, turn the selector lever to the right and pump with the hand pump until the boom lowers onto the ground.

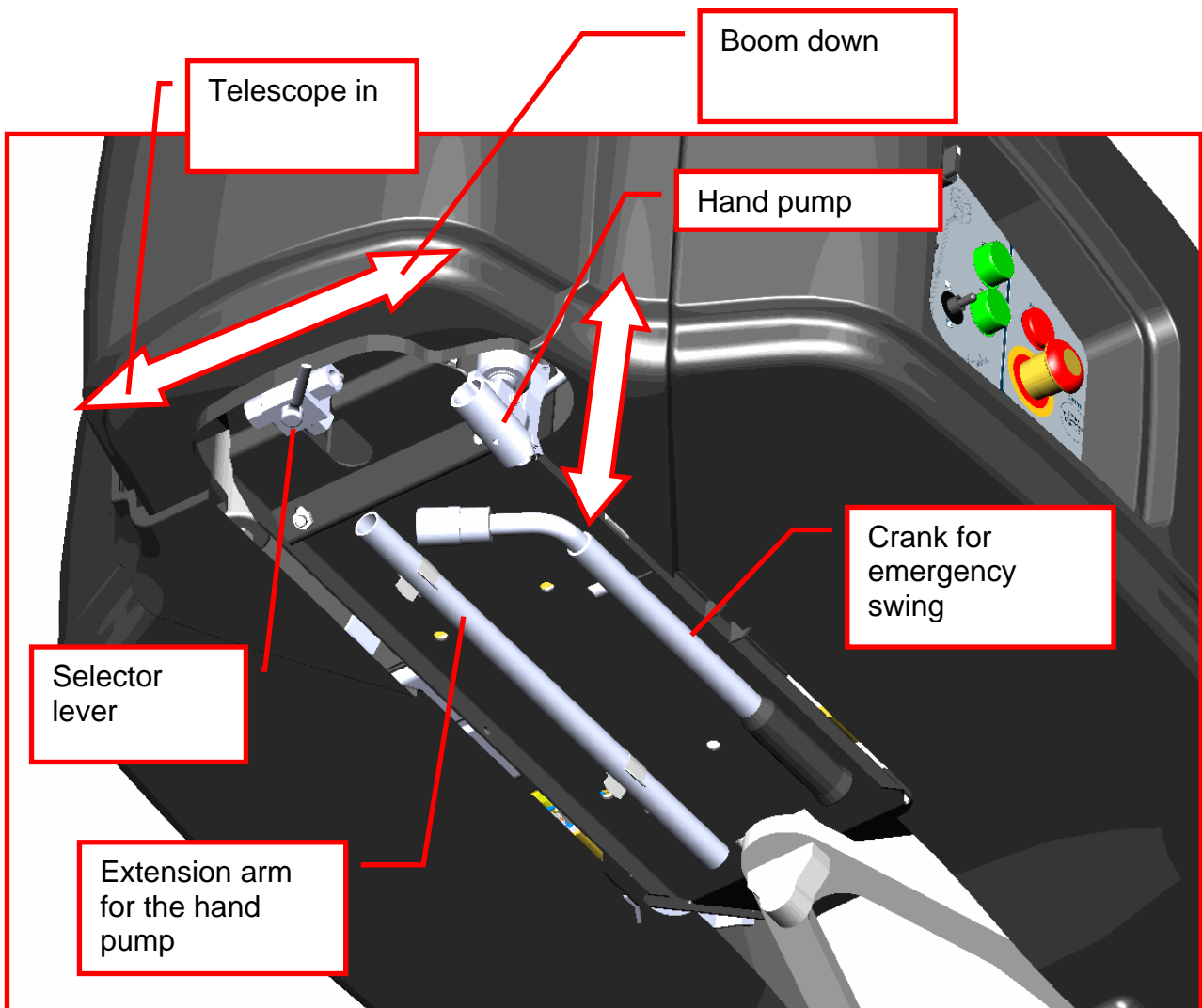

3. The boom can be turned by placing a crank on the worm gear shaft in the opening in the plastic cover of the turning device, and by turning it without haste in the desired direction. The crank is at the bottom of the turning device.

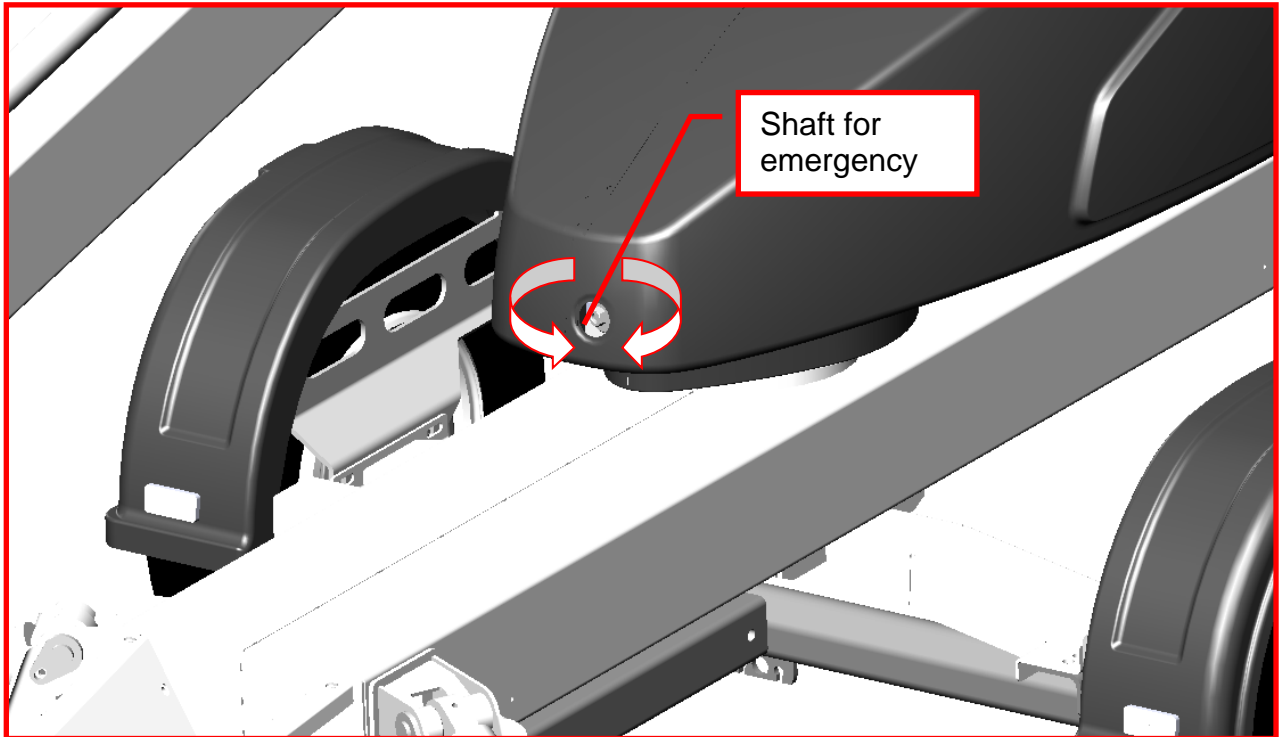



13 DRIVING DEVICE (option)

The hydraulic driving device is intended for moving the lift within the work area if the towing vehicle cannot be used.

1. Do not drive up or down the hill using the driving device if the gradient is greater than 5 per cent, i.e., more than 1/20 (corresponding to a descent of 0.5 m over a distance of 10 m). If the surface gradient is greater than this, you may lose control of the device. 
2. When driving on a slope, the tow-bar must always point towards the descent. Never drive with the driving device with the tow-bar pointing towards the ascent.
3. Always chock the wheels before disconnecting the unit from the towing vehicle.
4. Always apply the handbrake before disconnecting the unit from the towing vehicle. Only use the handbrake as a parking brake or for emergency stopping.
5. Never leave the lift on a slope being supported only by the self-braking action of the driving device.
6. When transferring the lift using the driving device:
 - **take care not to allow the wheel to roll over your foot**
 - **look out for sudden sideways movements of the tow-bar**
 - **be careful not to cause danger to other people and the environment**
7. Do not move the device on a slope using only hand-power. You may lose control over it and cause an injury.
8. Never park a vehicle combination on a slope.

14 USING THE DRIVING DEVICE (Option)

The hydraulic driving device is intended for moving the lift within the work area if the towing vehicle cannot be used.

1. Turn the selector switch (Q1) to position LCB – chassis centre.
2. Make sure that the platform is in the transport position and the outriggers are lifted in their upper positions
3. Make sure that the mains cable is long enough to cover the whole travel distance
4. Press the driving device against the wheel on both sides
5. Release the handbrake.
6. Drive the unit by turning the levers of the manual directional valve in the desired driving direction. Use the right-hand lever to drive the right wheel, and the left-hand lever to drive the left wheel.
7. Do not drive the jockey wheel into obstacles or potholes.
8. After the driving, apply the parking brake.
9. Disconnect the driving device from the tyre.

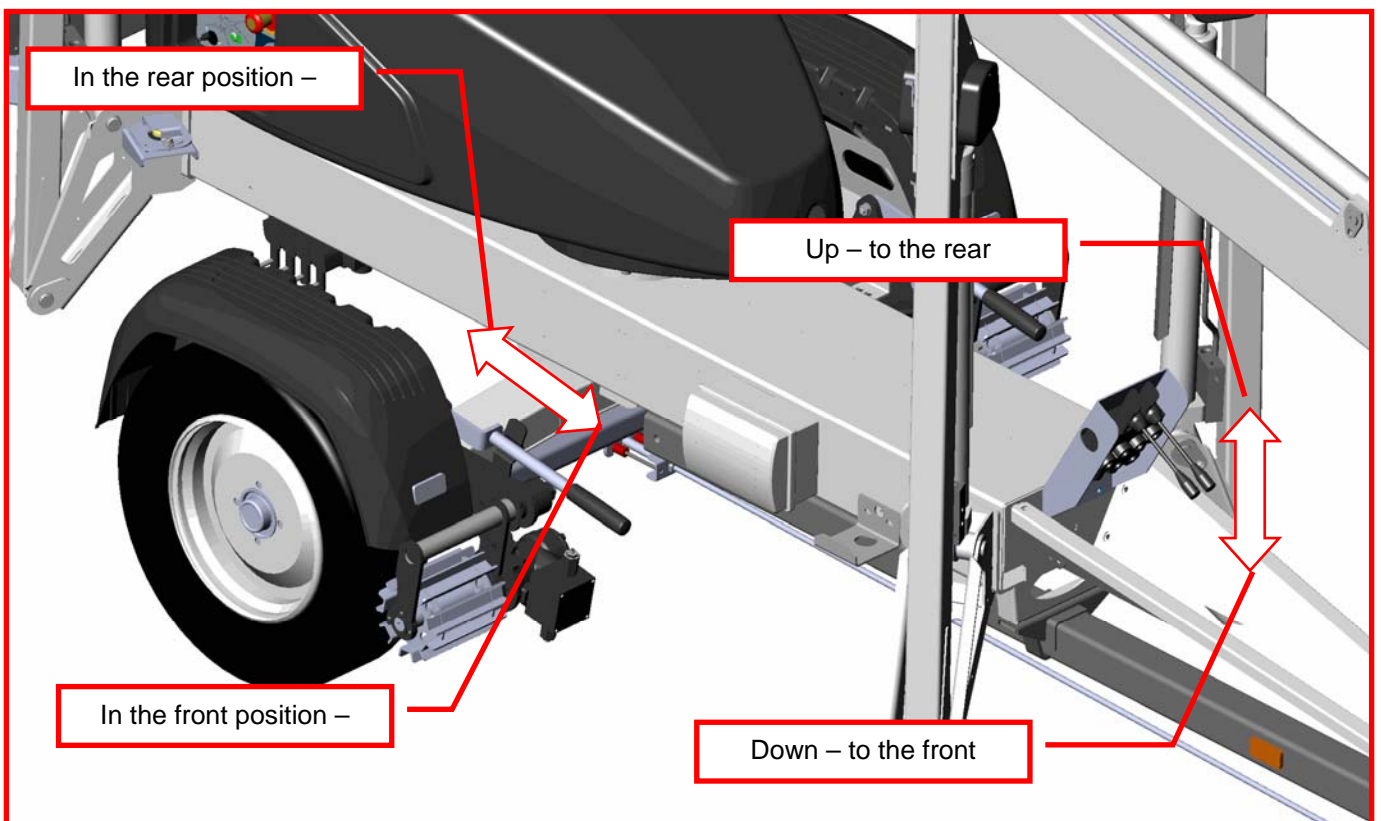

Note!

Be careful not to damage the tow-bar jockey wheel shaft by extending it too much. The jockey wheel must, however, be able to turn around freely.



15 SPECIAL INSTRUCTIONS FOR WINTER USE

- the lowest allowed operating temperature of the lift is -20 °C.
- if the temperature is below zero, let the power unit run for a few minutes before starting the movements
- start with a few movements to warm-up oil in the cylinders and to ensure proper operation of the valves
- check that the limit switches and the emergency descent devices are operational and clean (from dirt, snow, ice, etc.)
- protect the control panel and the platform from snow and ice whenever they are not in use

ALWAYS KEEP THE LIFT FREE FROM DIRT, SNOW ETC.

16 MEASURES TO BE TAKEN AT THE END OF THE WORKING DAY

1. Retract the telescope boom completely.
2. Check that the platform is perpendicular to the boom.
3. Lower the boom/platform onto the support on the tow-bar.
 1. if the platform is not in its lowest position, the limit switch on the transport support prevents the operation of the support outriggers
4. Close the control centre cover on the work platform.
5. Turn the selector switch Q1 to position OFF.
6. Disconnect the lift from the power supply.
7. Always take the selector switch key with you, when you leave the lift.

17 PREPARING THE LIFT FOR TRANSPORT

1. Fully retract the telescopic boom.
2. Check that the platform is perpendicular to the boom.
3. Lower the boom/platform onto the support on the tow-bar.
 - if the platform is not in its lowest position, the limit switch on the transport support prevents the operation of the support outriggers

4. Close the control centre cover on the work platform.
5. Turn the selector switch Q1 to the position OFF and disconnect the lift from the power supply.
6. Lift the support outriggers.
 - at first the rear support outriggers (do not damage the rear lights)
 - then the front support outriggers (do not damage the jockey wheel)
7. Apply the parking brake.
8. Make sure that the driving device is disconnected.

18 CONNECTION TO THE TOWING VEHICLE

1. Lift up and push forward the ball-coupling handle (in the driving direction). Now the ball-coupling is released.
2. Press the ball-coupling onto the towball using only a little force. The connection and locking take place automatically.
 - Clean and lubricate the ball-coupling regularly.
3. Connect the emergency stop wires and light plug to the vehicle. Check the cable for chafing and the proper operation of the wire.
4. Carefully release the parking brake and make sure that its locking is in order and that its handle stays in the lower position.
5. Lift up the jockey wheel to the transport position.

No load allowed on the platform during towing of the lift.



In particular, if you are parking or disconnecting the lift from the towing vehicle on a slope, apply the parking brake as firmly as possible. After having applied the parking brake, push the lift backward to make the reverse automatics release the brake shoes. The spring cylinder pulls the parking brake tighter. Thus the brakes of the vehicle are again properly on. If you leave the lift standing for a longer period of time, for example over the winter, we recommend propping it up to release any load from the wheels.

NOTE!

- **Always ensure before towing:**

- **transport position of the outriggers**
- **locking of the ball-coupling**
- **operation of the lights**
- **parking brake**
- **condition and pressure of the tyres**
 - rear axle **270 kPa (2.7 bar)**
- **safety wire**
- **locking of the brakes after transportation**
- **attachment of the jockey wheel in its upper position**
- **that the driving device is disconnected from the wheel**



INSTRUCTIONS FOR SERVICE AND MAINTENANCE

19 GENERAL SERVICE INSTRUCTIONS

- carry out the servicing and inspection of the lift in accordance with the instructions
- when it comes to more demanding repair works turn to a specialist or contact the distributor or the manufacturer of the lift
- do not modify the lift without written consent from the manufacturer
- any such faults which may affect the operational safety of the unit must be repaired before the lift is next used
- do not let oil spill on the ground
- keep the lift clean, especially the platform
- clean up the lift before service and inspection
- use genuine spare parts
- support the platform, boom system and support outriggers in a position in which the load does not rest on the structure under repair or cause any other danger (e.g. transport position or use of supporting structures)

19.1 LIFTING

- the device may be lifted with two slings, each with a load-carrying capacity of at least 1,000 kg, by the four lifting lugs (see picture)

Be careful not to damage the device during the lifting!
Only use lifting gear that are explicitly intended for this purpose

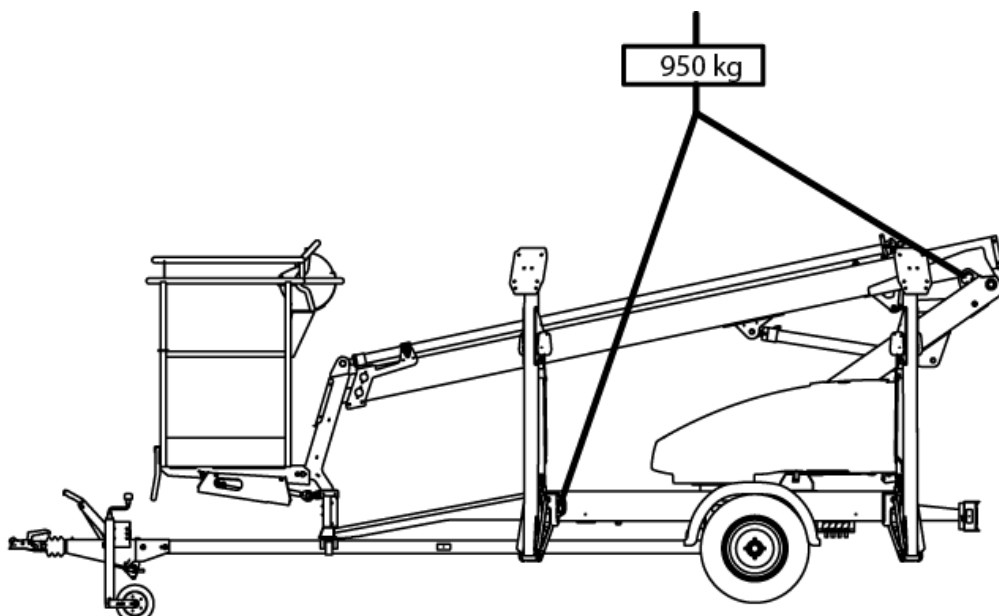

19.2 SERVICE AND INSPECTION INSTRUCTIONS

1. The first service after 20 hours of operation

- change the pressure filter element for the hydraulic oil
- adjust the brakes according to the instructions in point "Wheel brakes and bearings"
- check the wheel bolts for tightness (90 Nm) after about 100 km of driving

2. Daily service

- check the oil level in the hydraulics, top up if necessary
- check the hydraulic connections
- check the structure of the unit visually
- check the operation of the emergency descent and emergency stop functions
- check the operation of the safety devices (see point "Operation of the safety devices")

3. Weekly service

- check the tyre pressure (270 kPa, 2.7 kPa)
- lubricate the joint pins (see point "Lubrication plan")
- check the sliding surfaces of the telescope and apply teflon on them if necessary
- check the clearance between the slide pads and surfaces and adjust the pads if necessary

Check the operation of the swing limiters, and the condition of the hoses and electric wires routed to the chassis. The swing limiters should allow the boom to be turned at maximum 355° in both directions from the boom support.



4. Service every six months

- check the condition of the brakes
- check the the wheel bolts for tightness (90 Nm)
- grease the gear ring of the turning device

5. Periodic service every 12 months in accordance with the instructions for regular servicing below in this manual



IF THE LIFT IS OPERATED UNDER DEMANDING CONDITIONS (IN EXCEPTIONALLY HUMID OR DUSTY ENVIRONMENT, CORROSIVE CLIMATE, ETC.), THE INTERVALS BETWEEN THE OIL CHANGES AND THE OTHER INSPECTIONS SHALL BE SHORTENED TO MEET THE PREVAILING CONDITIONS IN ORDER TO MAINTAIN THE OPERATIONAL SAFETY AND RELIABILITY OF THE LIFT.

THE PERFORMANCE OF THE PERIODIC SERVICING AND THE INSPECTIONS IS ABSOLUTELY MANDATORY, BECAUSE THEIR NEGLIGENCE MAY IMPAIR THE OPERATIONAL SAFETY OF THE LIFT.

THE GUARANTEE WILL NOT REMAIN VALID, IF THE SERVICING AND THE PERIODIC INSPECTIONS ARE NOT PERFORMED.





19.3 LUBRICATION PLAN

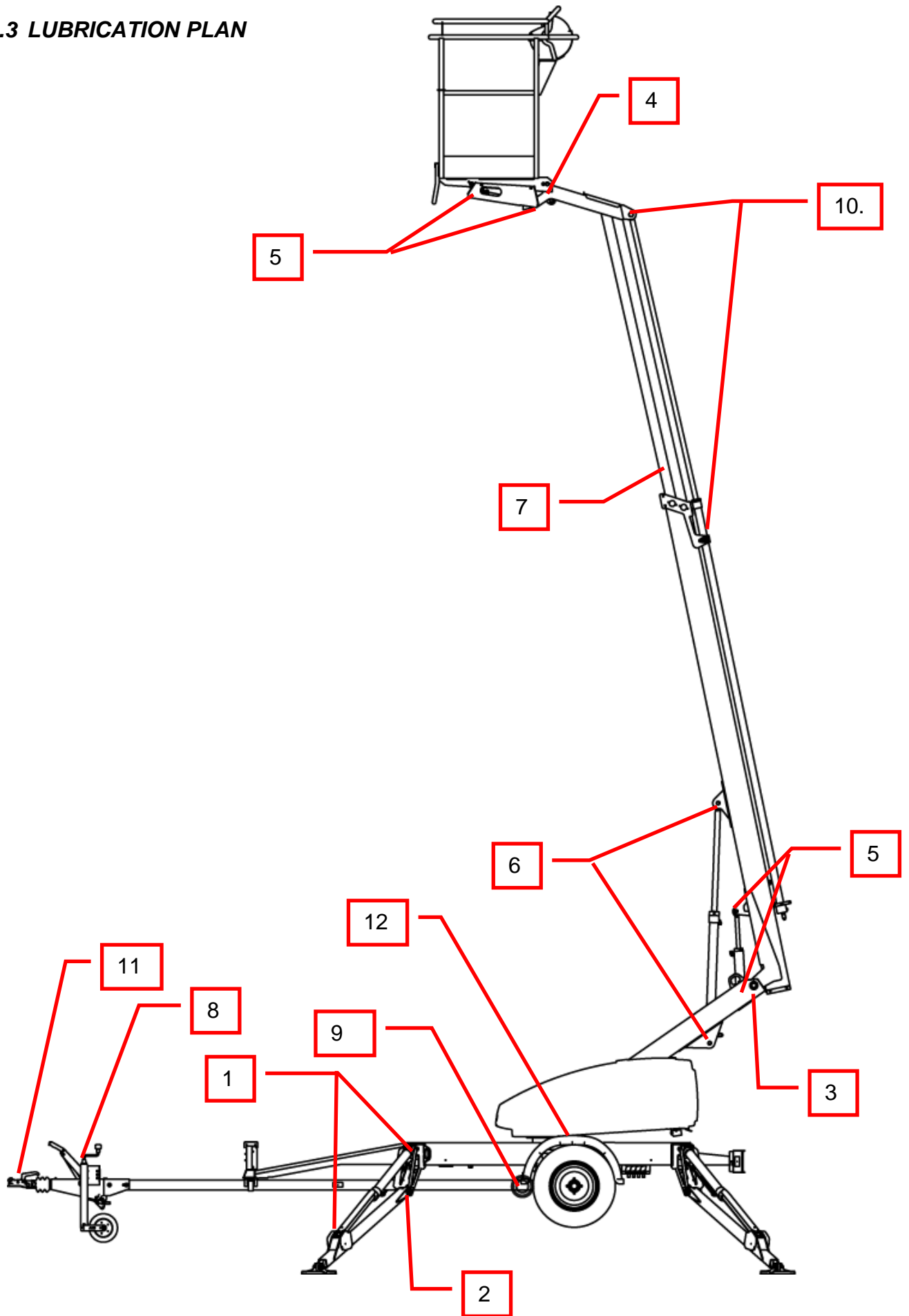

EVERY 50 HOURS

1. Bearings of the outrigger cylinders
2. Bearings of the outriggers
3. Bearings of the boom
4. Bearings of the platform
5. Bearings of the levelling cylinders
6. Bearings of the lifting cylinder
7. Sliding surfaces of the telescope
8. Jockey wheel slide and threads
9. Plain bearings of the driving device

TWICE A YEAR

10. Bearings of the telescope cylinder
11. Overrun brake - overrun
12. Turning device bearings and gear ring
NOTE! Greasing the turning bearing: 2 strokes/nipple

Lubricant Esso Beacon EP2 or equivalent

Moving parts of the mechanism of the outrigger limit switch system must be lubricated every 50 hours.

If necessary, apply a thin grease film on moving parts of the ball coupling.

Always lubricate the lift and apply a protective grease film immediately after the washing.

19.4 LONG-TERM STORAGE

Clean the machine carefully, lubricate it and apply protective grease to it before putting it into storage for a longer period of time. Repeat the cleaning and lubrication procedures while resuming the operation.

The periodic inspections must be executed following the steps described in the instructions.

19.5 LOAD HOLDING AND LOAD REGULATION VALVES

Check of operation

1. To check the load holding valves of the outrigger cylinders for tightness, measure the height of the chassis from the floor separately at each outrigger, and observe the height in a few minute's time.
2. To check the tightness of the lifting cylinder's load regulation valve, drive the boom to a position where its location can be reliably measured. Observe the possible movement of the boom in a few minute's time.
3. To check the load regulation valve of the telescope cylinder for tightness, extend the telescope and stop the movement at any position, measure the stroke and observe in a few minutes time that the stroke does not change. (Note! Drive the boom to an almost vertical position).
4. To check the load regulation valve in the levelling system of the platform for tightness, put a load of about 100 kg onto the platform and measure the distance from the rear edge of the platform to the floor. Observe in a few minutes time that the height position does not change.

Service instructions

1. Remove and clean the valve.
2. Check the O-rings and replace them if necessary.
3. Put the valves carefully in place.
4. If necessary, replace the valve.
5. Do not change the pre-set values of the valves.

Support the platform, the boom system and the outriggers in a position, where the load does not rest on the structure to be repaired. Ensure that there is no residual pressure left in the cylinders.



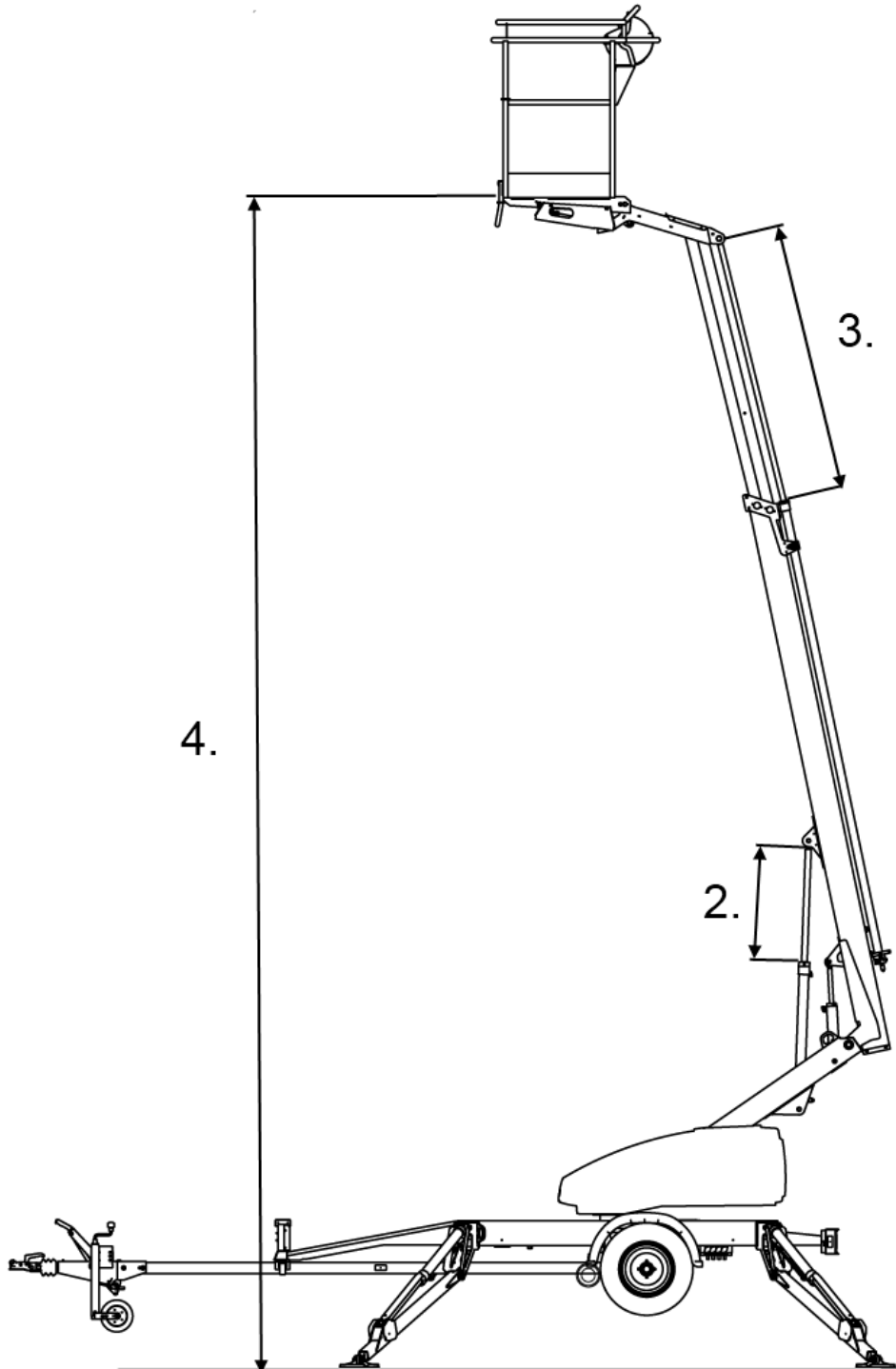
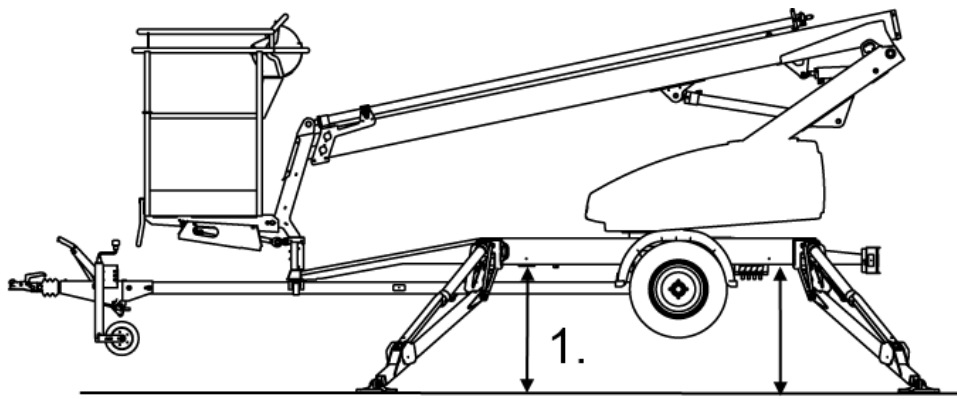

19.6 WHEEL BRAKES AND BEARINGS

Adjusting the brakes

1. Raise the lift's wheels off the ground, and support the lift in this position.
2. Make sure that the wheels can rotate freely.
3. The brake rods must be slack (with the handbrake released).
4. Check the attachment of the extension sleeves for the brake rods.
5. Turn the adjustment wheel behind the hole shown by the arrow until the wheel can no longer be turned by hand.
6. Turn the bolt until the wheel again can be turned freely.

If you tighten the brake system too much, the brakes overheat during transportation and the force required from the driving device will increase.

We recommend performing a test run after the adjustment. To ensure flawless operation, apply the brake 2–3 times in the course of the test run.

Adjustment of the bearing clearance

The wheel bearings are lubricated for life and do not require any service.
(The bearings need no additional lubrication, and they neither need nor can be re-adjusted).

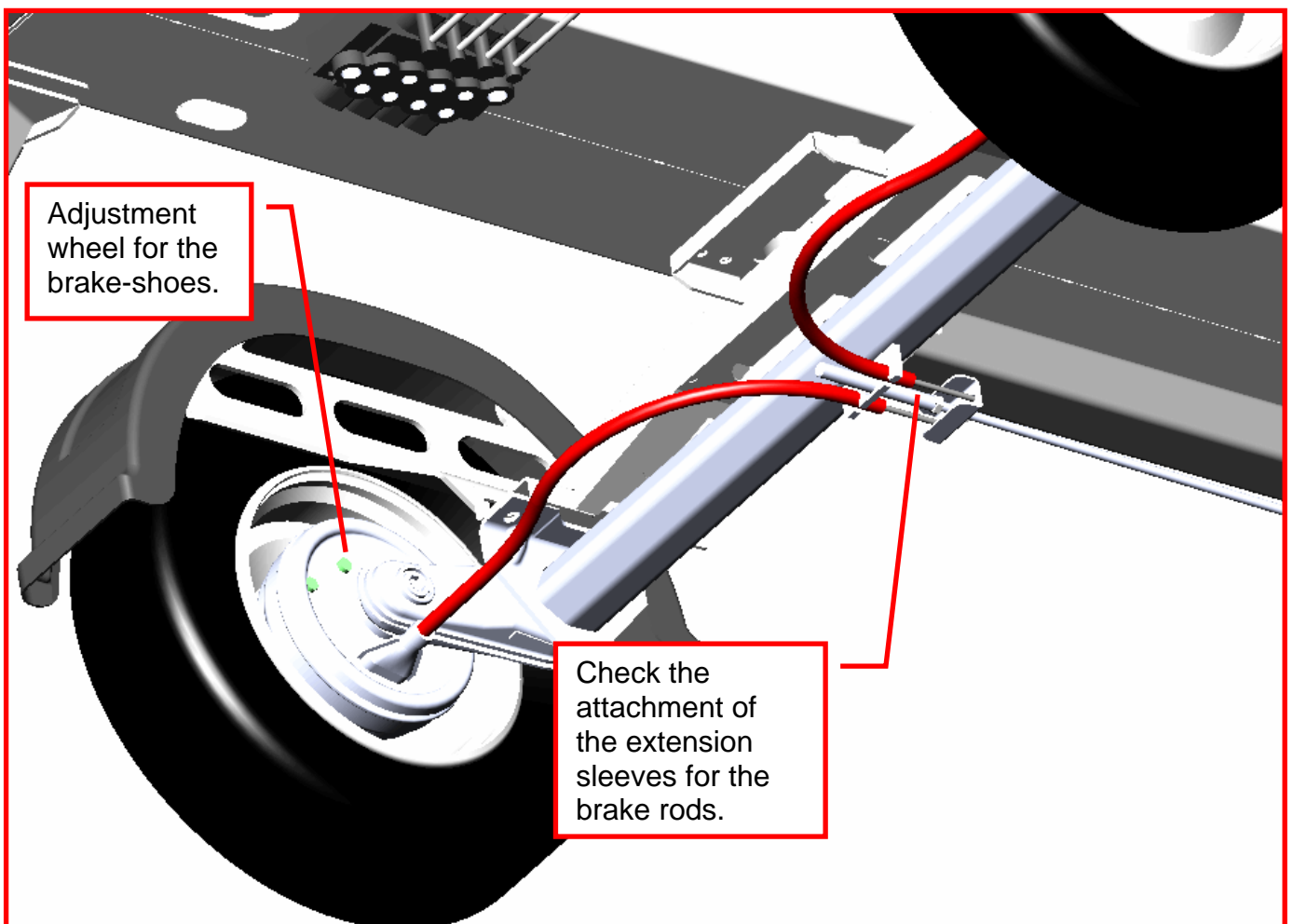

19.7 LEVELLING SYSTEM OF THE PLATFORM

- A so-called slave–master cylinder system is applied for levelling the platform:
 - The slave cylinder, that is located under the platform, is controlled by a master cylinder.
 - The platform keeps its level position only if the valves in the system are tight.
 - The levelling system comprises the following parts:

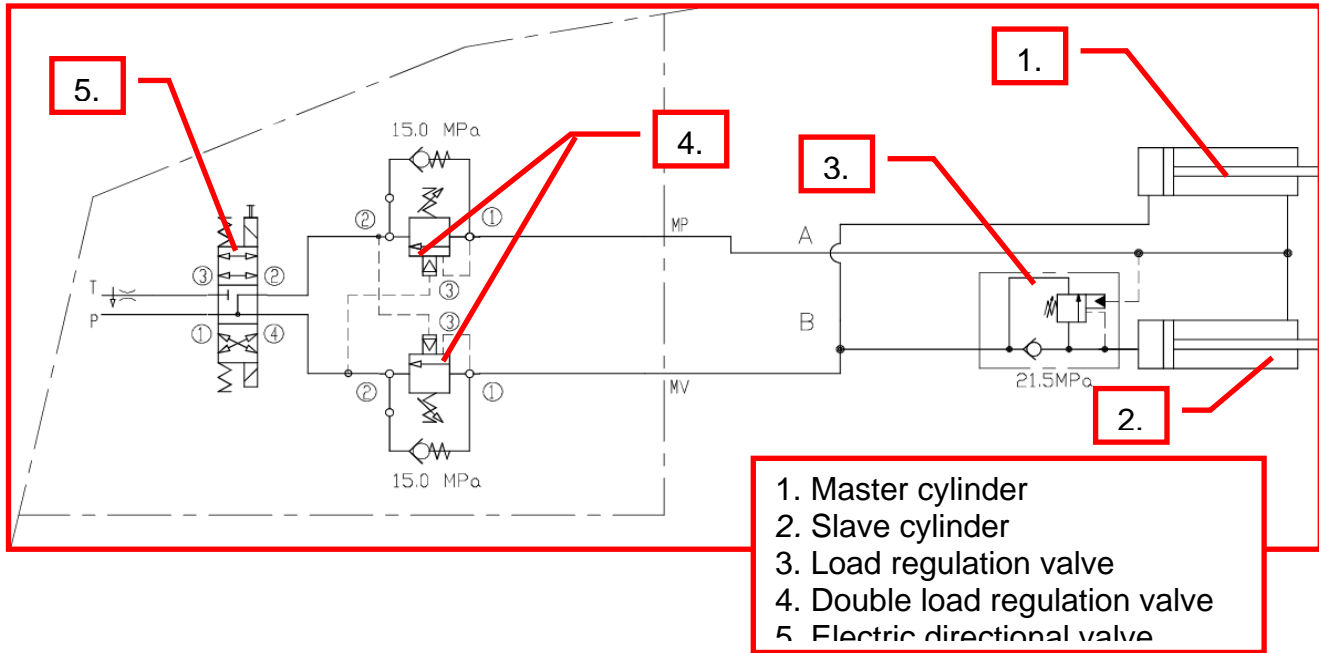

- If the platform, viewed by the operator, drifts forwards, the reason can be:
 - A leak in the double load regulation valve of the slave cylinder (on the piston rod side) in the direction of the electric directional valve (which is not tight).
 - An internal leakage in the cylinder.
- If the platform, viewed by the operator, drifts backwards, the reason can be:
 - A leak in the load regulation valve (4) on the piston (bottom) side of the slave cylinder in the direction of the electric directional valve (5) (which is not tight).
 - An internal leakage in the cylinder.

The leak will cause drifting of the platform until the load regulation valve (3) under the platform is closed. The closing is caused by dropping of the pressure on the piston rod side to the opening ratio, which is 5:1

If the valves are not tight, refer to the service instructions under point "Load holding and load regulation valves"

Settings of the load regulation valves:

- the opening pressure of the double load regulation valves (4) is 21.5 MPa (215 bar)
- the opening pressure of the load regulation valve (3) under the platform is 15.0 MPa (150 bar)

Do not change the preset values.

19.8 REGULAR SERVICING

The lift shall be serviced regularly at intervals of 11 - 12 month.

Under demanding conditions where moist, corrosive substances or corrosive climate may speed up the deterioration of the structure and induce malfunctions, the inspection must be performed more often and the influence of corrosion and malfunctions must be reduced by using appropriate protective means.

Only technical specialists who are familiar with the structure and the operation of the lift are allowed to maintain the lift.

We recommend turning to the service staff of the dealer.

19.9 SCHEDULE FOR REGULAR SERVICING

19.9.1 Clean the lift thoroughly before the service

The hydraulic and electric appliances must not be dismantled if they are not clean. Any contaminants in the system may cause malfunctions later on. Wash the lift externally.

NOTE! Be careful not to direct the high pressure water jet straight to the electric appliances, such as the control panels on the chassis and on the platform, relays, solenoid valves and limit switches.

- use pressure air to dry the electric devices, hydraulic connectors etc.before opening them
- apply appropriate moisture repellent to the electric appliances after the drying
- always protect the piston rods with e.g. CRC3-36 anti-corrosive agent after washing with a solvent

REMEMBER CLEANLINESS!



19.9.2 Change the hydraulic oil and replace the filter

(protect your skin against the hydraulic oil)

- remove the plug and drain the oil tank with the cylinders of the lift completely retracted (in the transport position)
- clean and rinse the oil tank with suitable agent
- replace the pressure filter
- install the drain plug
- refill the tank with fresh oil, the volume required for change is about 10 litres (factory filling **Mobil EAL 32**) The viscosity class of the hydraulic oil must be **ISO VG32** or **ISO VG15** and the oil must meet the requirements according to DIN 51524- HLP. Material Safety Data Sheet EXXON MOBIL no. 581017-60
- never mix different oil sorts
- as required, top up hydraulic oil to the level with the upper mark on the dipstick while the lift is in the transport position

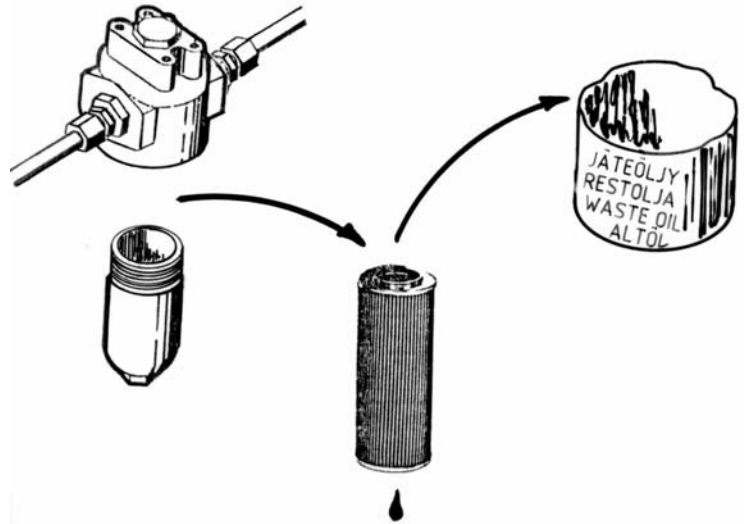

VOLUME OF HYDAULIC OIL REQUIRED FOR OIL CHANGE IS ABOUT 10 LITRES

19.9.3 Check the hydraulic hoses and pipes

Replace any externally damaged hoses or clashed pipes. Check the connections for tightness.

19.9.4

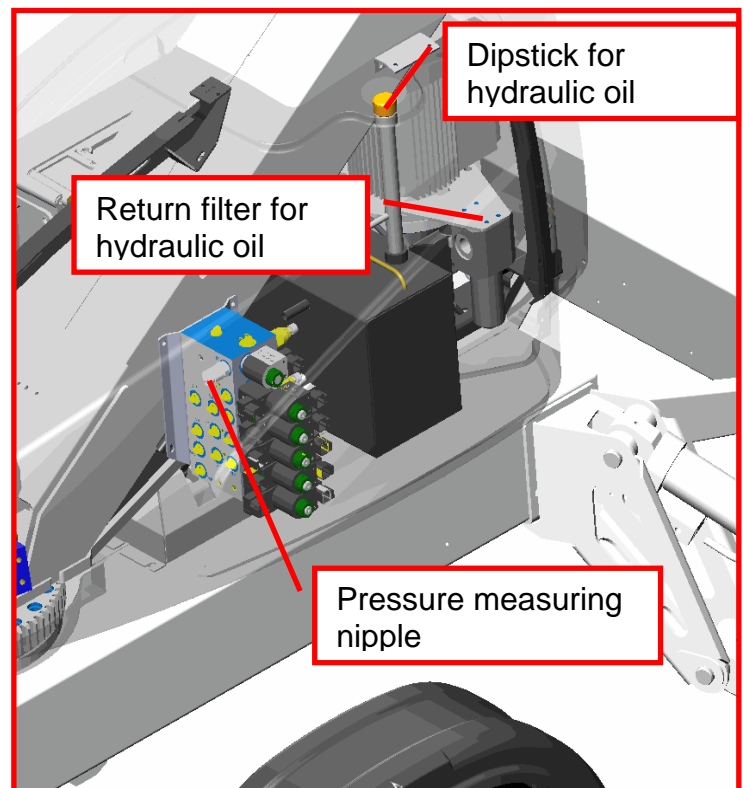

19.9.4 Check the operation of the swing limiter

- check the condition of the hoses and electric wires routed from the turning device to the chassis
- check that the hoses and the electric wires are not twisted, while the boom is resting on the support
- the swing limiters should allow the boom to be turned at maximum 355° in both directions from the boom support
- the swing limiter mechanism shall be tightened so firmly that it cannot be easily moved by hand
 1. Lift the boom away from the support, and turn it sufficiently far to the side
 2. Test that the limiter cannot be moved too easily by hand
 3. Tighten the bolt as required
 4. Drive the boom back onto the support, in the position shown in the picture, ensuring that there is no twisting of the hoses and wires that are routed through the slewing ring.

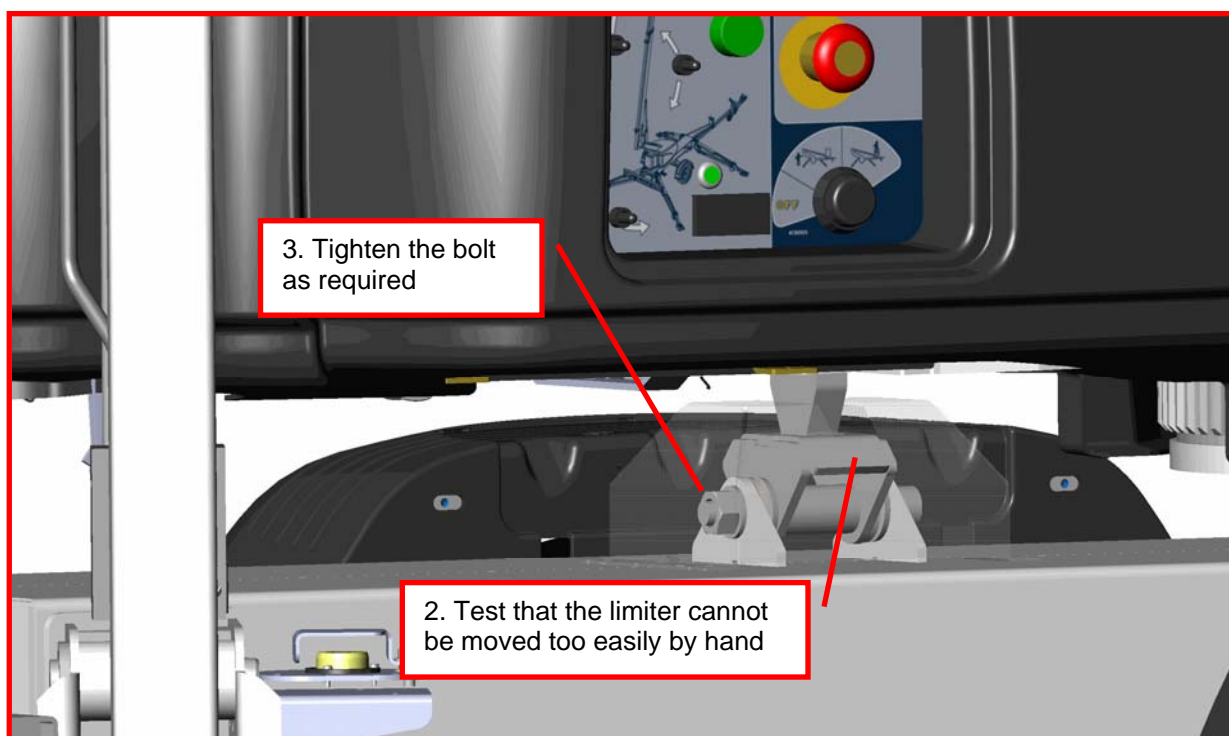

19.9.5 Inspect joints of the support outrigger

- lower the outriggers slightly
- swing the outriggers back and forth in the horizontal plane and check the joints for play
- check the operation and condition of the limit switch mechanisms on the outriggers
- replace any worn out parts

- lubricate the joints (see point "Lubrication plan")

19.9.6 Inspect the cylinders, and lubricate the joint bearings

- (See point "Lubrication plan")
- Lower the outriggers into the support position.
- from the chassis control centre, drive the lifting cylinder into its upper position, and check the connections for tightness and the condition of the piston rod
- from the chassis control centre, drive the lifting cylinder into its lower position, and check the connections for tightness
- from the chassis control centre, retract and extend the telescope cylinder, and check the condition and tightness of the cylinder
- lubricate the joints of the lifting cylinder, the telescope cylinder and the levelling cylinders
- inspect the outrigger cylinders and lubricate their joints

NOTE!
ALWAYS DRIVE THE LIFT INTO A POSITION, WHERE IT IS SAFE TO CHECK THE CYLINDER



19.9.7 Inspecting the boom and the frame

- extend the telescope and inspect the platform, its attachment and the boom
- inspect the joints of the boom and the play of the sliding pads – readjust if necessary. Lubricate the sliding surfaces
- inspect the turning device and its attachment, lubricate the turning bearing and the gear ring (2 nipples)

NOTE! Excess grease pressure may press out the turning bearing seal.

- check the play at the turning bearing: Max. allowed axial play is about 1 mm.

Outer ring M12, 115 Nm
Inner ring M14, 215 Nm

- check the attachment bolts of the turning device for tightness:



If you have to turn open or tighten the attachment bolts, do not forget to use bonding adhesive (tighten crosswise)

- check the chassis and the welded seams on it; especially around the turning device and attachment points of the outriggers
- inspect the outriggers.
- check the tow-bar, in particular its attachment to the chassis and axle
- lubricate the bearings of the boom and outrigger joints

19.9.8 Check the overrun

- attachment of the overrun
- clearance
- condition of the towball-coupling
- condition of the locking device
- check that the overrun brake mechanism moves freely:
 - stop the lift
 - push in the towball-coupling with its push rod
 - the push rod and the tow-ball-coupling must return to their initial outer position of themselves following the action of the gas cushion of the hydraulic absorber

19.9.9 Inspection of the axle and the suspension

- check the attachment of the axle
- check condition of the rubber absorbers and the torsion arms

19.9.10 Inspecting the safety devices

- check the attachment and the condition of the limit switches externally (see point "Operation of the safety devices")
 - from the tow-bar (transport position of the platform, RK3)
 - support outriggers (RK11, RK12, RK13 and RK14)

19.9.11 Operation of the safety devices while they are controlled from the chassis control panel

- Raise the lift onto the outriggers, and move the platform off the transport position
 - the outriggers must not operate in any position of the selector switch
- while the support outriggers are in their upper position
 - the boom must not operate in any position of the selector switch
- lift the boom and test the following:
 1. emergency stop (S1)(see point "Operating controls in the platform control panel UCB")
 2. emergency descent (see point "Emergency descent system")

19.9.12 Measuring pressure of the hydraulic system

- connect the pressure gauge to the measuring nipple
- max. pressure for warm (40–60 °C) oil is 20.5–21.5 MPa (205–215 bar)
- the turning pressure is 6 MPa (60 bar)
- if you have to readjust the pressure, secure the new setting with a seal

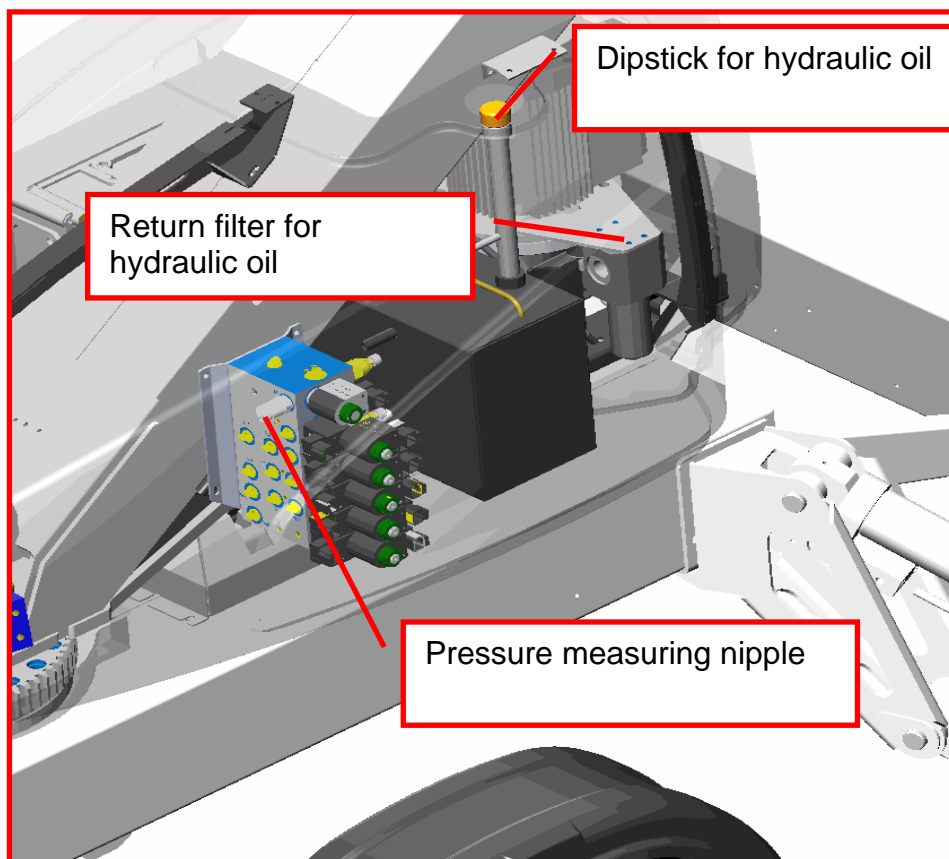

19.9.13 Check the operating controls on the platform

- check the overall condition of the electric appliances inside the box and spray with moisture repellent, if necessary
- check the cables
- test the sound signal (S10) and the emergency stop (S4)(see point "Operating controls in the platform control panel UCB").
- test all movements

19.9.14 Warning stickers and adhesive tapes

- make sure that all the warning stickers and adhesive tapes are legible – replace if necessary

19.9.15 Inspect the brakes and the driving device

- remove the wheels
- clean the brake system and check the settings
- check the free movement of the brake shoes the operation of their return springs
- replace any worn out linings
- check the condition of the driving device and lubricate the joints
- put the wheels in place and tighten the wheel bolts (90 Nm)
Check the bolts for tightness after about 100 km of driving.
- check the tyre pressure:
- check the free movement of the overrun brake and the parking brake
- check the safety wire

Wheel bolts: 90 Nm

On the rear axle: 270 Kpa (2,7 bar)
on the jockey wheel of the tow-bar: 250
Kpa (2,5 bar)

19.9.16 Traffic lighting

- Check the condition of the lights and the reflectors

19.9.17 Anti-corrosion treatment

- Repeat the anti-corrosion treatment using e.g. Tectyl 210R anti-corrosion agent

19.9.18 Test-run

- Perform a test-run with a load of 130 kg following the loading instructions.

Check the structures after the test-run.



19.9.19 Draw up an inspection protocol

- Save your own copy and give an other copy to the customer.

NOTES



20 INSPECTION INSTRUCTIONS

All lifting equipment and lifting gear used at a construction site must always be inspected before use. The lifts and related lifting gear used on a work site shall be subjected to a regular maintenance inspection; if possible once a week. (VNA 205/2009, 14§ - 18§)

Keep a journal of any notable shortcomings and defects observed and advise the foreman of them.

20.1 FIRST INSPECTION

The initial inspection and test loading of the Dino access platforms is performed by the manufacturer. A protocol which accompanies the lift is drawn up of the inspection.



20.1.1 SAMPLE OF INSPECTION PROTOCOL FOR THE ACCESS PLATFORM



TEST CERTIFICATE

DATE:

www.dinolift.com

START-UP TESTS:

Inspection place: Dinolift Oy

Inspector's signature:

Reunanen Jari NT0226

BASIC KNOWLEDGE

Manufacturer: Dinolift OY

Place of manufacture: Finland

Address: Raikkolantie 145

32210 LOIMAA

Importer:

Type of lift: Boom platform

Scissor platform

Mast platform

Chassis: Car

Self propelled

Trailer mounted

Boom: Articulated boom

Telescope boom

Articulated telescope boom

Scissor

Fixed mast

Telescope mast

Outriggers: Hydraulic turning

Hydraulic pushing

Mechanical

TECHNICAL SPECIFICATIONS

Machine and type: DINO 105TL

Max. platform height: 8,5 m

Number of manufacture YGCD105TL 0 D 10001

Max. Outreach: 6,5 m

Year of manufacture 2013

Max. lifting capacity: 130 kg

Boom rotation: + / - 355°

Max. person number: 1

Support width: 3,25x3,3 m

Max. additional load: 50kg

Transport width: 1,5 m

Power supply: 230VAC

Transport length: 5,44 m

Lowest temperature: -20 °C

Transport height: 1,99 m

Weight: 950 kg

Basket size: (ø) 0,85 m x 0,7 m

Inspection points:

(Y = meet standards N = do not meet standards)

	Y	N		Y	N
A. STRENGTH					
1. Certificate of material	<input checked="" type="checkbox"/>	<input type="checkbox"/>	6. Plate for supports	<input checked="" type="checkbox"/>	<input type="checkbox"/>
2. Certificate of strength	<input checked="" type="checkbox"/>	<input type="checkbox"/>	7. Safety colours	<input checked="" type="checkbox"/>	<input type="checkbox"/>
B. STABILITY					
1. Certificate of stability test	<input checked="" type="checkbox"/>	<input type="checkbox"/>	D. SAFETY REQUIREMENTS		
2. Working space diagram	<input checked="" type="checkbox"/>	<input type="checkbox"/>	1. Indicating device for horizontal position	<input checked="" type="checkbox"/>	<input type="checkbox"/>
C. GENERAL REQUIREMENTS					
1. User's manual	<input checked="" type="checkbox"/>	<input type="checkbox"/>	2. Locking device and lockings	<input checked="" type="checkbox"/>	<input type="checkbox"/>
2. Place for safekeeping for user's manual	<input checked="" type="checkbox"/>	<input type="checkbox"/>	3. Stop device for lifting	<input checked="" type="checkbox"/>	<input type="checkbox"/>
3. Machine plate - checking plate	<input checked="" type="checkbox"/>	<input type="checkbox"/>	4. Stop for opening of support	<input checked="" type="checkbox"/>	<input type="checkbox"/>
4. Load plate	<input checked="" type="checkbox"/>	<input type="checkbox"/>	5. Safety distances	<input checked="" type="checkbox"/>	<input type="checkbox"/>
5. Warning plate	<input checked="" type="checkbox"/>	<input type="checkbox"/>	6. Position of working face	<input checked="" type="checkbox"/>	<input type="checkbox"/>
			7. Structure of working face	<input checked="" type="checkbox"/>	<input type="checkbox"/>
			8. Emergency descent system	<input checked="" type="checkbox"/>	<input type="checkbox"/>
			9. Limit devices	<input checked="" type="checkbox"/>	<input type="checkbox"/>



E. ELECTRIC APPLIANCES		G. SAFETY DEVICE	
1. Electric appliances	<input checked="" type="checkbox"/> <input type="checkbox"/>	1. Safety limit switch	<input checked="" type="checkbox"/> <input type="checkbox"/>
		2. Sound signal	<input checked="" type="checkbox"/> <input type="checkbox"/>
F. CONTROL DEVICES		H. LOADING TEST	
1. Protections	<input checked="" type="checkbox"/> <input type="checkbox"/>	1. Overload test = 195 kg (150%)	<input checked="" type="checkbox"/> <input type="checkbox"/>
2. Symbols / directions	<input checked="" type="checkbox"/> <input type="checkbox"/>	2. Funktional test = 145kg (110%)	<input checked="" type="checkbox"/> <input type="checkbox"/>
3. Placings	<input checked="" type="checkbox"/> <input type="checkbox"/>		
4. Emergency stop	<input checked="" type="checkbox"/> <input type="checkbox"/>		
FAILINGS AND NOTES	_____		
Failings have been repaired. Date: _____ Signature: _____			

Dinolift Oy
Raikkolantie 145
FIN-32210 LOIMAA, FINLAND
Tel. +358 - 20 -1772 400, Fax +358 - 2 - 7627 160, e-mail: dino@dinolift.com

20.2 DAILY INSPECTION (START-UP INSPECTION)

To be always performed at a new worksite and in the beginning of every working day.



The inspection is performed by the user.

In the inspection attention shall be paid to the following issues:

- establish the load-bearing capacity of the ground (see points "Start-up" and "Load-bearing capacity of the base")
- verify the standing stability of the lift
- control the due operation of the position indicator
- test the operation of the emergency stop system both from the platform and the chassis control centre
- test operation of the emergency descent system
- test the alarm signal
- check the signal light for the outrigger limit-switches (H3)
- check the operation and cleanliness of the lights and reflectors
- check the condition of the operating controls and test all the work movements
- check the condition of the access routes, the platform gate and the handrails
- check the operation of the limit switches, which block the movements of the boom (see point "Operation of the safety devices when controlled from the chassis control centre").
- check the limit switch, which prevents the operation of the outriggers (see point "Operation of the safety devices when controlled from the chassis control centre").
- check the hydraulic system for tightness
- test the brakes
- check the structures visually
- observe the location of nearby power lines (see point "General safety regulations")

20.3 MONTHLY INSPECTION (MAINTENANCE INSPECTION)

The inspection shall be performed by a person who is well familiar with the lift.

Task list for the inspection:

- perform the measures of the daily inspection
- check the attachment points of the boom and the platform
- check the operation and condition of the platform's levelling system
- perform visual inspection of the load-bearing structures
 - chassis
 - turning device
 - telescope (fully extended)
 - support outriggers and their joints
 - welded seams for cracks, corrosion or breaches
 - whether possible repair welds have been duly executed
- check that the platform does not "drift" (see point "Load holding and load regulation valves")
- check that the outrigger do not "drift" (see point "Load holding and load regulation valves")
- check the hydraulic oil level
- check the hoses and the cables at the turning ring (for leaks/chafing)
- check the tyres and the tyre pressure
- check the wheel bolts and the rims
- check the turning gear play
- check the operation of the driving device (option)
- check the condition and attachment of the electric wires
- check the condition of the overrun
- make sure that all the signs, warnings and pictorials for the operating controls and the control equipment are in place, in good condition and clean
- check that the lift is clean all over

20.4 ANNUAL INSPECTION (REGULAR INSPECTION)

This inspection shall be performed by a skilled technician or an expert inspection body with documented evidence of competence according to the requirements presented under point "Inspections" . In the inspection special attention has to be paid to the condition of the steel structures, the safety devices and the operating system.

Clean the lift before the inspection

The inspection incorporates the following measures and checks:

- perform the measures of the daily and monthly inspection
- inspect thoroughly the hydraulic system
- inspect the power unit
 - connect the pressure gauge to the measuring point in the hydraulic system (see point "Measuring the pressure of the hydraulic system")
 - drive the "telescope in" movement at the speed II against its end position to make the oil flow through the relief valve
 - read the pressure in the gauge;
 - max. pressure for warm (40–60 °C) oil is 20.5–21.5 MPa (205–215 bar)
 - the turning pressure is 6 MPa (60 bar)
- load-holding check-valves on the outriggers
 - lift the device off the ground with the outriggers and measure the distance to the chassis at each outrigger
 - step on the platform and extend the telescope keeping the boom level. Turn the boom round a few times, stop at the initial position and check that the distance between the ground and the outriggers has not changed.
 - lift the outriggers from the ground and leave them in this position for about 10 minutes.
 - Observe that the outriggers do not lower of themselves.
- load-holding check-valve on the lift cylinder
 - lift the boom from the lower control panel to an angle of about 45° and extend the telescope. Observe about 10 minutes that the boom does not lower of itself.
- load regulation valve of the telescope cylinder
 - lift the boom from the chassis control panel and extend the telescope slightly; leave it in this position for about 5 minutes
 - make sure that the telescope does not retract of itself

- load regulation valve of the levelling system
 - put a load of about 80 kg on the platform
 - lift and lower the boom 4 - 5 times
 - make sure that the position of the platform does not change
- electric directional valves
 - operate all boom and turning movements and check that they all work properly and that the movements stop as soon as the levers are released
- manually operated directional valves
 - check that the valves of the support outriggers and the driving device work properly and no movements are executed while the spools are in the neutral position
- cylinders
 - lower the outriggers to the support position and check the condition of the piston rods and the wiper rings
 - check the cylinders for external oil leaks
 - lift the boom into its upper position and check the condition of the piston rod and the wiper ring of the lifting cylinder
 - check the condition of the piston rod and the wiper ring of the master cylinder in the slave cylinder system
 - lower the boom and check the condition of the piston rod and the wiper ring of the slave cylinder under the platform
- hoses
 - check the hoses for any leaks or chafing
- pipes
 - check that there are no dents, leaks, trace of corrosion or chafing at the clamps
 - check that the pipes are properly fastened
- connections
 - check the hose and pipe connectors for leaks
- inspect thoroughly the electric system
 - check that the control panel boxes are dry, clean and tight.
 - check the condition of the cable connections and their protection against moisture
 - check the condition and attachment of the limit switches
 - check the limit switch lead-throughs for tightness
 - check the connections of the electric valves
 - check the connections of the solenoid valves
 - perform visual inspection of all electric wiring
 - check the condition of the mains cable plug
 - check the condition of the electric motor.
 - check the operation of the fault current switch
- check the attachment points of the hydraulic cylinders
 - check the condition of the bearings and pins of the outrigger cylinders, and the locking of the pins

- check the condition of the lifting cylinder bearings and pins and the locking of the pins
 - check the attachment and condition of the telescope cylinder bearings and pins.
 - check the condition of the gas springs
 - check the condition of the master and slave cylinder bearings and pins and the locking of the pins
- check the condition of the boom joint
 - check the bearing and the pin of the boom joint and the locking of the pin
- check the support outriggers and their footplates
 - check the mechanical structure of the outriggers and the welded seams. The structures must not show signs of deformations or cracks No fractures or cracks allowed in the welded seams.
 - check the footplates for deformations, cracks or breaches Also check that the footplate can turn freely on its joint.
- inspect the boom
 - extend the telescope and check that there are no permanent deformations, dents or traces of substantial wear in the boom
 - also check the welded seams for wear, cracks or breaches
 - check the boom attachment for cracks or breaches
 - check the condition of the platform brackets
 - check the locking of the platform pin
 - check the condition of the cable chain, its clamp brackets as well as the tightness of the screw connections
 - check the play and attachment of the gliding surfaces on the boom.
- inspect the platform
 - general condition
 - check that the platform does not show signs of deformations, substantial wear or buckles
 - check that the handrails, the steps, the gate and the attachment of the gate are in order
 - check the condition of the platform floor plate
 - check the platform carrier for notable buckles or deformations
- check all the protective covers
 - check the condition of the slave cylinder guard
 - check the condition of the boom end cover, covers of the turning device, the safety device cover, cover of the platform control centre, the rear light cover, and the covers of the outrigger limit switches
- perform visual inspection of all the screw connections
- inspect the turning device
 - general condition
 - check the play and attachment of the angular gear
 - check the condition of the gear ring
 - check the play of the turning gear
 - check the tightness of the turning bearing attachment screws

- check the condition of the chassis
 - general condition
 - check the attachment of the tow-bar to the chassis and the axle
 - check the condition of the overrun and its attachment to the tow-bar.
 - check the axle and its attachment to the chassis
 - check the attachment and condition of the brake wires and rods
 - check the rims, the tightness of the wheel bolts, the tyres and the tyre pressure
 - check the condition of the driving device (option), attachment of the parts and condition of the covers for the electric components
 - check the condition of the transport support of the boom
- perform a test-run/ test of operating controls with a load of 130 kg on the platform
- also check the operation of the limit switches during the test run (refer to the service instructions)
 - the limit switches on the outriggers, which prevent the operation of the boom movements
 - the limit switches on the tow-bar, which prevent the use of the outriggers
- after the test-loading and the test-run make sure that the loading has not caused any defects, such as fractures or permanent deformations of dangerous nature, on the steel structures or other loaded parts.
- draw up a protocol of the regular inspection with following articles:
 1. inspection form
 2. data of repair welds
 - b) date of repair
 - c) repaired by whom
 - d) what was repaired
- when the machine is ready for operation after the annual inspection, mark the inspection date on the inspection plate affixed to the lift

20.5 EXTRAORDINARY INSPECTION (INSPECTION AFTER AN EXCEPTIONAL SITUATION)

The inspection is required if the lift has been damaged in a manner which may affect its strength or safe operation.

- Thus the lift shall be inspected according to the instructions for the start-up inspection.
- perform a test-loading with an overload of 25 % and a stability test of the lift
- a protocol shall be drawn up for the inspection

20.6 TEST LOADING INSTRUCTIONS FOR REGULAR INSPECTION

1. Place the lift on an even surface with good carrying capacity.
2. Drive the outriggers to their lowest position (the minimum support width).
3. Turn the boom to the side from the tow-bar and lower it on the ground.
4. Put a weighed load of 130 kg onto the platform.
5. Lift the boom to as high as it goes and extend the telescope to its full length (maximum lifting height).
6. Lower the boom to a horizontal position (maximum outreach).
7. Turn the boom round over 360° and establish the standing stability.
8. Retract the telescope and lower the boom.

After the above mentioned test loadings and the subsequent inspection have been completed without finding any defects in the structure or stability of the lift, the lift may be used provided that the reach and platform load restrictions, presented in the reach/platform load chart of this manual, are observed.

The max. allowed load on the platform is 130 kg

- In conjunction with the first, i.e. start-up, inspection, the lift shall be subjected to an overload test with an excess load of 50 % and after that the supporting structures shall be thoroughly inspected.
- In conjunction with the annual inspection the lift shall be subjected to a regular inspection, a test-run and a test loading with maximum permissible load and a thorough inspection of the supporting structures.
- The first inspection shall be recorded in the start-up inspection protocol - the test runs shall be recorded in the protocols for the annual and regular inspection.



25.1 NOTES