



## STAR 8 S



### GO EVERYWHERE

- > High precision driving and smoothness
- > Easy access to the platform: dedicated anti-slip step
- > Quick machine with mobile pothole protections
- > Intuitive control box with battery level indicator in platform
- > Smart transportability and lifting
- > Platform extension deck: + 0,4 m

### WITH THE BEST VALUE FOR MONEY

- > Haulotte Activ'Energy Management takes care of your batteries
- > 4-stage-cylinder mast: no chain, no cable
- > Minimal maintenance & downtime
- > Direct electric drive with maintenance-free AC motors (brushless)
- > Easy access to components (2 swing out trays)
- > Haulotte Activ'Screen (onboard diagnostic)

## VERTICAL MASTS

### TECHNICAL DATA

#### STAR 8 S

Working height	7.95 m
Platform height	5.95 m
Horizontal outreach	0.4 m extension
Lift capacity - inside	200 kg (1 Pers.)
<b>A</b> Length	1.4 m
<b>B</b> Width	0.79 m
<b>C</b> Height - stowed	1.98 m
<b>D</b> Wheelbase	1.06 m
<b>E</b> Ground clearance	6 cm
Platform size	0.77 x 1.38 m
Platform size with extension	0.77 x 1.78 m
Drive speed proportional	0.5 - 4.5 km/h
Turning radius - outside	1.7 m
Tilt alarm	1,5° / 3°
Gradeability	25 %
Max driveable platf. height	5.95 m
Hydraulic system capacity	9 l
Tyres - non marking	318 x 108
Power source	4 x 6 V - 180 Ah (C5)
Weight	1 150 kg

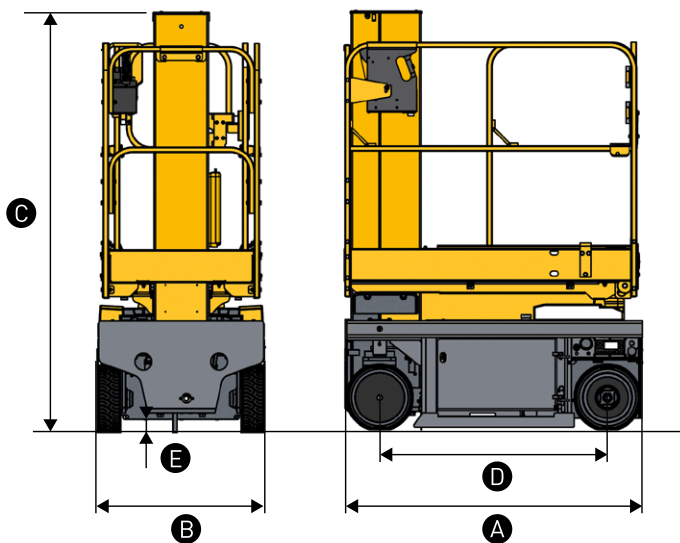

### STANDARD EQUIPMENTS

- > Haulotte Activ'Energy Management: Smart CAN charger
- > Haulotte Activ'Screen
- > 24 V electric drive brushless AC motors (free maintenance)
- > 4 x 6 V - 180 Ah batteries
- > Battery level indicator
- > Fork lifting pockets
- > Hoisting and lifting eyes
- > Door entry gate with lock
- > Platform extension deck: + 0,4 m
- > Mobile pothole protection
- > 2 rear driving wheels
- > 2 front steering wheels
- > Non-marking tires
- > Electric brake release
- > Hourmeter
- > Horn
- > Travel alarm
- > Emergency stop
- > Lowering system
- > 2 control boxes at basket and ground levels
- > Mobile upper control box
- > Drive speed selector on upper control box
- > 2 towing hooks

### OPTIONS AND ACCESSORIES

- > Haulotte Activ'Energy Management: automatic or manual battery waterfilling systems Telematics ready
- > Maintenance-free batteries
- > Flashing light
- > Power to platform
- > Tool tray
- > Upper control box cover
- > Ground-fault circuit interrupter 30 mA
- > Cold weather hydraulic oil
- > Biodegradable hydraulic oil

