

HA32RTJ PRO - HA100RTJ PRO - HA41RTJ PRO - HA130RTJ PRO

For online reference and to download the manuals for your machines HAULOTTE®, go to :
<https://www.e.technical-information.com>
or, scan the QR Code below :



Operator's manual

**HA32RTJ PRO - HA100RTJ PRO -
HA41RTJ PRO - HA130RTJ PRO**

4001008360

E 06.21

USA / GB



A**FOREWORD**

1 - User responsibility	10
1.1- Owner's responsibility	10
1.2- Employer's responsibility	10
1.3- Trainer's responsibility	10
1.4- Operator's responsibility	11
2 - Safety	12
2.1- Safety instructions	12
2.1.1 - Misuse Hazards	12
2.1.2 - Falling Hazards	12
2.1.3 - Overturning / Tip-over Hazards	13
2.1.4 - Electric Shock Hazards	16
2.1.5 - Explosion / Fire Hazards	17
2.1.6 - Crushing / Collision Hazards	17
2.1.7 - Uncontrolled movement Hazards	18
3 - Safety inquiries	19
4 - Incident notification	19
5 - Compliance	20
5.1- Product modification	20
5.1.1 - Implementing manufacturer safety campaigns	20
5.2- Product specifications	20
5.3- Change of Ownership Notification	21
5.4- Declaration of conformity	22

CONTENTS

B

FAMILIARIZATION

1 - General safety	23
1.1 - Intended use	23
1.2 - Decal content	24
1.3 - Symbols and colors	25
1.4 - Level of severity	25
1.5 - Symbols legend and definitions	26
2 - Models description	27
3 - Primary machine components	28
3.1 - Layout	28
3.2 - Ground control box	30
3.2.1 - Layout	30
3.2.2 - Display Panel (LED'S 1 - 10)	32
3.3 - Platform control box	34
3.3.1 - Layout	34
3.3.2 - Display Panel (LED'S 101 - 117)	36
3.4 - DPF (Diesel Particle Filter) (If equipped - DEUTZ 2,2 TDC engine only)	38
3.4.1 - Automatic regeneration	39
3.4.2 - Manual regeneration	39
3.4.3 - To stop manual regeneration	39
3.5 - Axle extension control box	40
3.5.1 - Layout	40
4 - Performance Specifications	41
4.1 - Technical characteristics	41
4.2 - Working area / Range of motion	45
5 - Decals and markings locations	47



C**PRE-OPERATION INSPECTION**

1 - Recommendations	61
2 - Working area assessment	61
3 - Inspection and Functional test	62
3.1- Daily inspection	62
4 - Safety functional checks	65
4.1- E-Stop button check	66
4.2- Activation of controls	67
4.3- Fault detector	67
4.3.1 - Indicators/LED's test	67
4.3.2 - Buzzers test	68
4.4- Automatic engine cut-out	68
4.5- Overload sensing system	68
4.6- Oscillating axles	68
4.7- Slope warning device	69
4.8- Travel speed limitation	69
4.9- Movement speed	70
4.10- On-board electronics	70
4.11- Radius limitation	70
4.12- Axle extension	70
4.13- Drive buzzer	71
4.14- Boom control system	71

D**OPERATION INSTRUCTIONS**

1 - Operation.	73
1.1- Introduction	73
1.2- Operation from the ground control box	73
1.3- Operation from the platform control box	74
2 - Ground control box	77
2.1- To start and stop the machine	77
2.2- Movement control	77
2.3- Additional controls from the ground control box	78
3 - Platform control box	79
3.1- To start and stop the machine	79
3.2- Drive and steer control	79
3.3- Movement control	80
3.4- Additional controls	81
4 - Axle extension control box	82
4.1- Prepare the machine	82
4.2- Axle extension operation	84
4.2.1 - For rear axle extension	84
4.2.2 - For front axle extension	85
4.3- Axle retraction operation	86
4.3.1 - For front axle retraction	86
4.3.2 - For rear axle retraction	87

CONTENTS

5 - Link piece position check	88
6 - Radius limitation.	89
6.1- Principle	89
6.2- Procedure	89
6.2.1 - Front radius limitation	89
6.2.2 - Rear radius limit	89
7 - Rescue and emergency procedures	90
7.1- In case of power loss	90
7.2- To rescue operator in platform	91
7.2.1 - Operation of overriding system from ground control box	92
7.3- No power available	92
8 - Transportation	93
8.1- Putting in transport position	93
8.2- Machine layout — HA32RTJ PRO - HA100RTJ PRO - HA41RTJ PRO - HA130RTJ PRO	95
8.3- Unloading	97
8.4- Towing	98
8.4.1 - Disengaging the drive hubs	98
8.4.2 - Re-engaging the drive hubs	98
8.5- Storage	99
8.6- Lifting operation	100
8.6.1 - Safety precautions	100
8.6.2 - Necessary equipment	100
8.6.3 - Preliminary procedures	101
8.6.4 - Procedure for the use of slings	101
9 - Cold Weather Recommendations	105
9.1- Engine oil	105
9.2- Hydraulic oil	106
9.3- Preheating operation	106



E**GENERAL SPECIFICATIONS**

1 - Machine dimensions	108
2 - Major component masses	110
3 - Acoustics and vibrations	110
4 - Wheel/Tire assembly	111
4.1 - Technical specifications	111
4.2 - Inspection and maintenance	111
5 - Options	113
5.1 - On-board generator	113
5.1.1 - Principle	113
5.1.2 - Procedure	113
5.2 - Welder's kit	114
5.2.1 - Description	114
5.2.2 - Characteristics	114
5.2.3 - Safety precautions	114
5.2.4 - Pre-operation inspection	114
5.2.5 - Operation	114
5.2.6 - Assembly - Dis-assembly	115
5.2.7 - Specific decals	116
5.3 - Plumber's kit	117
5.3.1 - Description	117
5.3.2 - Characteristics	117
5.3.3 - Safety precautions	117
5.3.4 - Pre-operation inspection	117
5.3.5 - Operation	118
5.3.6 - Assembly - Dis-assembly	118
5.3.7 - Specific decals, optional	119
5.4 - Activ' Shield Bar - SECONDARY GUARDING SYSTEM (if fitted)	120
5.4.1 - Description	120
5.4.2 - Characteristics	120
5.4.3 - Safety precautions	121
5.4.4 - Pre-operation inspection	122
5.4.5 - Operation	122
5.4.6 - Specific decals	123
5.5 - Swing gate	124
5.5.1 - Description	124
5.5.2 - Characteristics	124
5.5.3 - Safety precautions	124
5.5.4 - Pre-operation instructions	124

CONTENTS

F**MAINTENANCE**

1 - General	125
2 - Maintenance Schedule	126
3 - Inspection program	126
3.1- General program	126
3.2- Daily inspection	127
3.3- Periodic inspection	127
3.4- Reinforced inspection	127
3.5- Major inspection	128
4 - Repairs and adjustments	129

G**OTHER INFORMATION**

1 - Conditions of warranty	131
2 - Subsidiary contact information	131
2.1- California warning	132

H**INTERVENTION REGISTER**

1 - Intervention register	135
--	------------



A - Foreword

You have just purchased a HAULOTTE® product and we would like to thank you for your business.

The aerial work platform is a device for lifting people designed and manufactured with the intent to enable users to access overhead elevated temporary workplaces with the necessary tools and equipment. All other uses or alterations/modifications to the aerial work platform must be approved by HAULOTTE®.

This manual shall be considered a permanent component of the machine and shall be kept with the aerial work platform in the designated Manual Holder, at all times.

Safe operation of this product can only be assured if you follow the operating instructions contained in this manual. To ensure proper and safe use of this equipment, it is strongly recommended that only trained and authorized personnel operate and maintain the aerial work platform.

We would particularly like to draw your attention to 2 essential points :

- Comply with safety instructions.
- Use the equipment within the specified/published performance limits.

With regard to the designation of our equipment, we stress that this is purely for commercial purposes and not to be confused with the technical specifications. Only the specifications in this manual should be used to study the suitability of the equipment for the intended use.

This operator's manual is specific to the HAULOTTE® products listed on the cover page of this manual.



Original language and version :

Manuals in English and French are the original instructions. Manuals in other languages are translations of the original instructions.

The operator's manual does not replace the basic training required for equipment operators. HAULOTTE® has compiled this manual to assist in safe and efficient operation of the products covered in the manual.

The manual must be available to all operators and must be kept in a legible condition. Additional copies can be ordered from HAULOTTE Services®.

Stay Safe and keep working with HAULOTTE® !

For online reference and to download the manuals for your machines HAULOTTE®, go to :

<https://www.e.technical-information.com>

or, scan the QR Code below :



A - Foreword

1 - User responsibility

1.1 - OWNER'S RESPONSIBILITY

The owner (or hirer) has the obligation to :

- To inform operators of the instructions contained in the Operator's Manual.
- Follow local regulations regarding operation of the machine.
- To replace all manuals or decals that are either missing or not legible. Additional copies can be ordered from HAULOTTE Services®.
- To establish a preventive maintenance program in accordance with the manufacturer's recommendations, taking into account the environment and severity of use of the machine.
- To perform periodic inspections in accordance with HAULOTTE® recommendations and local regulations.

All malfunctions and problems identified during the inspection shall be corrected before the aerial work platform is returned to service.

1.2 - EMPLOYER'S RESPONSIBILITY

The employer has the obligation :

- To authorize the operator to use the machine.
- To inform and familiarize the operator with the local regulations.
- Forbid anyone from operating the machine if :
 - Under the influence of drugs, alcohol, etc.
 - Subject to fits, loss of motor skills, dizziness, etc.

1.3 - TRAINER'S RESPONSIBILITY

The trainer must be qualified to provide training to operators in accordance with applicable local regulations. The training must be given in an obstacle-free area until the trainee is considered competent as defined by the training program undertaken.

A - Foreword

1.4 - OPERATOR'S RESPONSIBILITY

The operator has the obligation to :

- Read and understand the contents of this manual and familiarize himself/herself with the decals affixed on the machine.
- To inspect the machine before use according to HAULOTTE®'s recommendations..
- Inform the owner (or hirer) if the manual or any decals are missing or are not legible.
- To inform of any malfunctioning of the machine.

Operators must ensure that the inspections have been carried out by the owner and that they can use the machine for the purpose intended by the manufacturer.

Only authorized and qualified operators may operate HAULOTTE® machines.

All operators must become familiar with and fully understand the emergency controls and be able to operate the machine in an emergency.

The operator has the obligation to stop using the machine in the event of malfunction or safety problems on the machine or in the work area and report the problem immediately to his/her supervisor.

A

B

C

D

E

F

G

H

I

A - Foreword

2 - Safety

2.1 - SAFETY INSTRUCTIONS

2.1.1 - Misuse Hazards

- Do not use the machine for other purposes than to lift people, their tools and equipment to the desired position.
- Do not use the machine as a crane, material lift or elevator. Only use the machine as it was intended.
- Do not attach overhanging loads when raising or lowering the platform.
- Do not tie the boom or platform to an adjacent fixed or mobile structure.
- Do not use/operate the machine when alone. A survey person or immediate Supervisor must be present on the ground in case of emergency.
- Do not use a faulty or poorly maintained machine. Remove defective/damaged machine from service.
- Do not climb onto the compartment covers of the machine.
- Do not replace items critical to machine stability with items of different weight or specification.
- Do not replace factory-installed tires with tires of different specifications or ply rating.
- Do not alter or disable machine components that in any way affect safety and stability.
- Do not disable the safety devices.



2.1.2 - Falling Hazards

To enter or exit from the platform :

- The machine must be completely stowed.
- Face the machine to access the entry opening to the platform.
- Keep 3 points of contact (both hands and a foot) on the steps and the guardrail.
- Keep fingers away from moving parts near entry gate.



Before commencing operation :

- Ensure that guard rails are correctly installed and secured.
- Ensure that gate or sliding bar is in its securely locked position.
- If using a machine that has a swing gate, check that the entry gate closes by itself and gate latches and locks.
- Remove oil or grease from the steps, floor, handrail and the guardrails.
- Clean the floor of the platform (no debris).



A - Foreword

When in the platform :

- If local regulations require the wearing of a harness, use only the anchor points provided for this purpose.
- The correct use of the harness requires the lanyard to be connected to an anchorage point designated by the decals. Refer to this decal located on the platform.
- Hold on securely to the guardrails.
- Always keep your feet firmly on the floor of the platform.
- Do not sit, stand, or climb on the platform guard rails.
- Do not lean on the gate or sliding bar.
- Do not lean over the guard rails or climb over them. Only work in the platform area within the guard rails.
- Do not exit the platform until it is in the completely stowed position.
- Do not use the guardrail as a means of access to climb in or out of the platform.



2.1.3 - Overturning / Tip-over Hazards

Before positioning and operating the machine :

- Ensure that the surface is capable of supporting the machine weight including the rated capacity. Check the load bearing capacity of the supporting ground.
- Remain vigilant of driving direction reversal at the platform. Check the driving direction with the help of the red or green arrow on the chassis relative to the red and green arrows on the platform control box.
- Do not exceed the maximum rated capacity that includes the weight of both material and allowed number of occupants. Do not exceed the allowable number of occupants.
- Do not increase the working height (using extensions, ladder, etc.).
- Do not place ladders or scaffolds in the platform or against any part of this machine.



A- Foreword

- Place the loads uniformly distributed on the platform floor.
- Do not use the machine in winds exceeding the permissible limit.
- Do not increase the surface area of the platform exposed to wind. This includes adding panels, mesh, banners. Be aware when working with materials with a large surface area. This will add to the wind load on the machine.
- Do not raise the platform or drive with platform elevated on an incline exceeding the rated slope for the machine.
- Do not drive the machine on slopes or grades exceeding the specified limits.
- Do not replace components critical to stability with components of different weight or specification.
- Do not use the machine with material or objects hanging from the guardrail or the boom.
- Do not pull or push towards any object outside of the platform. Do not exceed the maximum allowable side force stated in the performance specifications.
- Do not use the machine to support any external structure.
- Do not use the machine to tow other machines or to drag materials.



A - Foreword

Using a machine on a slope



Do not drive the machine on slopes with gradients exceeding the authorised transversal and lateral limits for the machine.  Section B 4.1 - Technical specifications.

WIND : The aerial work platform can operate up to a maximum wind speed as indicated in the specifications. To identify the local wind speed, use the Beaufort scale below, use a wind gauge or an anemometer.

N.B.:-THE BEAUFORT SCALE OF WIND FORCE IS ACCEPTED INTERNATIONALLY AND IS USED WHEN COMMUNICATING WEATHER CONDITIONS. A WIND SPEED RANGE AT 10 M (32 FT 9 IN) ABOVE FLAT, CLEAR LAND IS ASSOCIATED WITH EACH DEGREE.

Beaufort scale

Force	Meteorological description	Observed effects	m/s	km/h	mph
0	Calm	Smoke rises vertically.	0 - 0,2	0 - 1	0 - 0,62
1	Very light breeze	Smoke indicates the wind direction.	0,3 - 1,5	1 - 5	0,62 - 3,11
2	Light breeze	Wind felt on the face. Leaves rustle. Weather vanes turn.	1,6 - 3,3	6 - 11	3,72 - 6,84
3	Slight breeze	Leaves and small twigs in constant motion. Flags move slightly.	3,4 - 5,4	12 - 19	7,46 - 11,8
4	Nice breeze	Raised dust and loose papers. Small branches are moved.	5,5 - 7,9	20 - 28	12,43 - 17,4
5	Nice breeze	Small trees in leaf to sway. Crested wavelets form on inland waterways.	8,0 - 10,7	29 - 38	18,02 - 23,6
6	Cool wind	Large branches in motion. Power lines and chimneys 'sing'. Umbrellas used with difficulty.	10,8 - 13,8	39 - 49	24,23 - 30,45
7	Near gale	Whole trees in motion. Inconvenience felt when walking against wind.	13,9 - 17,1	50 - 61	31 - 37,9
8	Gale	Some branches break. Generally we cannot walk against the wind.	17,2 - 20,7	62 - 74	38,53 - 45,98
9	Strong gale	The wind causes slight damage to buildings. Tiles and chimney stacks are blown off.	20,8 - 24,4	75 - 88	46,60 - 54,68

A - Foreword

2.1.4 - Electric Shock Hazards

The machine is not electrically insulated and does not provide protection from contact or proximity to electrically charged conductors.

Always position the lift at a safe distance from electrically charged conductors to ensure that no part of the machine is within an unsafe area.

Respect the local rules and the minimum safety distance from power lines.

Minimum safe approach distances

Electric voltage	Minimum safety distance	
	Mètre	Feet
0 - 300 V	Avoid contact	
300 V - 50 kV	3	10
50 - 200 kV	5	15
200 - 350 kV	6	20
350 - 500 kV	8	25
500 - 750 kV	11	35
750 - 1000 kV	14	45

N.B.: -USE THIS TABLE EXCEPT WHERE LOCAL REGULATIONS INDICATE OTHERWISE.

- Do not operate the machine when close to live power lines, consider the movement of the machine and the sway of the electric power lines particularly in windy conditions.
- Do not operate the machine during lightning, thunderstorms, snow/ice or any weather condition that could compromise operator safety.
- Do not use the machine as a ground for welding.
- Do not weld on the machine without first disconnecting the battery terminals.
- Always disconnect ground cable first.
- The machine must not be used while charging the batteries.
- When using the AC power supply, ensure it is protected with a circuit breaker and residual current device.

Keep away from the machine if it contacts energized power lines. Personnel on the ground or in the platform must not touch or operate the machine until energized power lines are shut off.



A - Foreword

2.1.5 - Explosion / Fire Hazards

- Always wear protective clothing and eye wear when working with batteries and power sources/systems.

N.B.:-ACID IS NEUTRALIZED WITH SODIUM BICARBONATE AND WATER.

- Do not start the engine if you smell or detect liquid propane gas (LPG), gasoline, diesel fuel or other explosive substances.
- Do not work on or operate a machine in an explosive or flammable atmosphere / environment.
- Do not touch hot components.
- Do not bridge the battery terminals with metallic objects.
- Do not service the battery in proximity of spark, open flame, lit cigarettes.
- Do not fill up the fuel tank, when the engine is running and/or near a flame.

2.1.6 - Crushing / Collision Hazards

When in the platform :

- Check the work area for overhead clearance, for any obstacles besides and below the platform when raising/lowering the platform and or before driving.
- During movement, keep all the parts of the body inside the platform. Hold onto the guardrails on the opposite side to any surrounding structures. Take care to avoid trapping hands whilst holding the guardrails.
- To position machine close to a building/structure, it is recommended using the upper boom and or arms movement control functions to position, rather than driving machine closer to structure.
- Always cordon off the area around the base of the machine to keep personnel and other equipment away from the machine while in use.
- Warn personnel not to work, stand, or walk under a raised boom/platform.

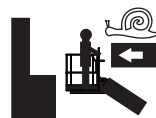

A

B

C

D

E

F

G

H

I

A - Foreword

- Do not drive in reverse direction (opposite the field of vision).
- Be aware of the boom position and tail swing when rotating the turret (turntable).
- Always ensure that the chassis is never kept any closer than 1 m (3 ft 3 in) to holes, bumps, slopes, obstructions, debris and ground coverings that may hide holes and other dangers.
- Keep non-operating personnel at least 5 m (16 ft 5 in) away from the machine when driving and slewing.
- Be aware of driving direction.
 - When turret is slewed/rotated 180°, the platform is now facing the rear of the machine.
 - Check the driving direction with the help of the red or green arrow on the chassis relative to the red and green arrows on the platform control box.
 - Also note that when changing the driving direction (Forward <> Reverse) the joysticks or switches must return to the neutral position before reversing the drive direction and for movement to occur.
- When driving, position the platform so as to provide the best possible visibility and to avoid any blind spots.
- Hold on securely to the guardrails.
- Personal fall protection equipment (PFPE) :
 - Occupants must wear a safety harness, personal protective equipment and comply with the applicable national regulations. Attach the safety harness lanyard to the designated anchorage points provided for this purpose on the work platform.
 - Operators must comply with the safety standards of the job site and the employer, as well as the applicable state regulations relating to the use of personal protective equipment.
 - All personal fall protection equipment (PFPE) must comply with current regulations, must be inspected and used in accordance with the manufacturer's instructions.
- Avoid contact with fixed or mobile obstacles (other machines).
- Other machines (crane, aerial work platform, etc.) operating in the work area increase the risk of crushing or collision. Restrict the operation of machines moving within the aerial work platform work area.
- Take into consideration the stopping distance, reduced visibility and blind spots of the machine.
- Limit travel speed to suit the ground surface condition, slope (incline), and people in the vicinity.

2.1.7 - Uncontrolled movement Hazards

Never use a damaged or malfunctioning machine.

Always respect the following rules :

- Maintain clearance from high voltage lines.
- Maintain clearance from generators, radar, electromagnetic fields.
- Never expose the batteries or electrical components to water (high pressure washer, rain).

A - Foreword

3 - Safety inquiries

Inquiries relating to design criteria/specifications of a product, standards compliance, or overall machine safety should be sent to the HAULOTTE® PRODUCT SAFETY department.

Each inquiry or request should include all relevant information; including contact name, telephone number, mailing address, email address, plus the machine model and serial number.

The HAULOTTE® Product Safety department will evaluate each request/inquiry and will provide a written response.

4 - Incident notification

Notify HAULOTTE® immediately when a HAULOTTE® product has been involved in an incident/accident leading to personal injury or death, or when there is a major property damage.

<p>HAULOTTE Group - EUROPE Product Safety Department</p> <p>Address : Rue Emile Zola - 42420 Lorette - France</p> <p>Tel : +33 (0)4 77 29 24 24</p> <p>Email : productsafety.europe@haulotte.com</p>	<p>HAULOTTE Group - Australia, India and Asia Product Safety Department</p> <p>Address : No.26 Changi North Way - Singapore 498812 - Singapore</p> <p>Tel : +65 6546 0123</p> <p>Email : productsafety.apac@haulotte.com</p>	<p>HAULOTTE Group - North & South America Product Safety Department</p> <p>Address : 3409 Chandler Creek Rd. - Virginia Beach, VA 23453 - United States</p> <p>Tel : +1 757 689 2146</p> <p>Email : productsafety.americas@haulotte.com</p>
--	--	---

Connect to our website : www.haulotte.com



A - Foreword

5 - Compliance

5.1 - PRODUCT MODIFICATION

It is strictly forbidden to modify a HAULOTTE® product. Any modification may violate Haulotte design parameters, local regulations and industry standards.

All modifications must be submitted in writing (form) and approved by the manufacturer.

Do not hesitate to contact HAULOTTE Services®, should you have any questions relating to the issued bulletin(s) or with questions on the policy itself.

5.1.1 - Implementing manufacturer safety campaigns

It is essential to implement the safety campaigns issued by the manufacturer. All of these campaigns are accessible on our website.

Connect to our website : www.haulotte.com



Never place a machine on the market without completing all the Safety Campaigns.

5.2 - PRODUCT SPECIFICATIONS

HAULOTTE® cannot be held liable for any changes to the technical characteristics/ specifications contained in this manual. HAULOTTE® has a continuous improvement policy in place for its product range. Given this policy, the Company reserves the right to modify products technical characteristics / specifications without notice.

Certain options/accessories can modify the machine's operating characteristics and its' associated safety. If your machine was originally delivered with options fitted, replacing a safety component associated with a particular option does not require any particular precaution other than those associated with the installation itself (static test).

Otherwise, it is essential to follow the manufacturer's recommendations as stated below :

- Installation by authorised HAULOTTE® personnel only.
- Update the manufacturer's identification plate.
- Have stability tests carried out by a certified agency/competent person.
- Ensure decals are updated.

A - Foreword

5.3 - CHANGE OF OWNERSHIP NOTIFICATION

It is important and necessary to keep HAULOTTE Services® updated with current ownership of the machine. This way, HAULOTTE® will be able to provide the necessary support for the product. If you have sold or transferred this machine(s); it is your responsibility to notify HAULOTTE Services®. It is not required to include Lessees/Renters of Leased/Rented machines on this form.

Connect to our website : www.haulotte.com



A

B

C

D

E

F

G

H

I

A - Foreword

5.4 - DECLARATION OF CONFORMITY



CE Declarations of Conformity only apply to machines that are certified for the European market.

Declaration of conformity - Thermal platforms



DECLARATION CE DE CONFORMITE
(EC DECLARATION OF CONFORMITY)



<p>Fabricant et personne autorisée à constituer le dossier technique <i>(Manufacturer and the person authorised to compile the technical file:)</i></p> <p>HAULOTTE GROUP</p> <p>Adresse du site de production <i>(Address of the Division)</i></p> <p>en conformité avec le modèle type <i>(In compliance with the Model Type)</i></p> <p>Nom commercial <i>(Commercial name)</i></p> <p>Numéro de série <i>(Serial number)</i></p> <p>Organisme notifié <i>(Notified body)</i></p> <p>Numéro de certificat <i>(Certificate number)</i></p> <p>Charge maximale d'utilisation <i>(Rated capacity)</i></p>	<p>Compliance & Regulation Director HAULOTTE GROUP S.A. RUE EMILE ZOLA</p> <p>42420 LORETTE FRANCE</p> <p>Nacelle élévatrice de personnel <i>(Mobile Elevating Work Platform)</i></p> <p>Modèle type de la machine concernée <i>(Type model of the concerned machine)</i></p> <p>Nom commercial de la machine concernée <i>(Commercial name of the concerned machine)</i></p> <p>Numéro de série de la machine concernée <i>(Serial number of the concerned machine)</i></p> <p>Nom et adresse de l'organisme notifié <i>(Name and address of the notified body)</i></p> <p>Numéro de certificat du type de machine <i>(Certificate number of the type of machine)</i></p> <p>Charge maximale d'utilisation de la machine concernée <i>(Rated capacity of the concerned machine)</i></p>
--	--

Nous déclarons que cette machine est conforme aux dispositions des Directives suivantes
(We hereby declare that this machine conforms with all the relevant provisions of the Directives listed below)

Directive CE Machine <i>(EC Machinery Directive)</i>	2006/42/CE
Se conforme aux principales exigences de la norme harmonisée <i>(This machine also fulfils the principles of the harmonised standard)</i>	EN280:2013 + A1:2015
Directive CE concernant la compatibilité électromagnétique <i>(EC Directive on electromagnetic compatibility)</i>	2014/30/EU
Directive CE RED concernant les équipements radio-électriques (si la machine est équipée) <i>(RED EC Directive on radio-electrical equipment (if machine equipped))</i>	
Directive CE d'émission de bruit <i>(EC Outdoor Noise Directive)</i>	2000/14/EC
Méthode de mesure <i>(Measurement method)</i>	Annex III-B
Niveau de puissance acoustique garanti <i>(LWA, Guaranteed sound level)</i>	101 dB
Niveau de puissance acoustique mesuré max <i>(LWA, Measured sound level)</i>	99 dB

Cette déclaration porte exclusivement sur la machine dans l'état où elle a été placée sur le marché
(This declaration relates exclusively to the machinery in the state in which it was placed on the market)

Toute modification de la machine décrite ci-dessus a pour effet d'invalider cette déclaration
(Any modification to the above described machine violates the validity of this declaration)

Nom et signature du Directeur du site de production <i>(Name and signature of the Division Director)</i>	Lieu <i>(Place)</i>
	Date <i>(Date)</i>

haulotte.com

B - Familiarization

1 - General safety

1.1 - INTENDED USE

Do not operate the product in the following situations :

- On soft, unstable or cluttered ground.
- With wind blowing faster than the permissible limit :
 - Check the allowable wind speed specified in the performance specifications tabulation.
 - Consult the Beaufort scale.
- Close to power lines. Keep a safe distance.
- If the machine is stored at a temperature out of range - 20°C / + 50°C (- 4°F / + 122°F).
- In an explosive atmosphere / environment.
- During storms.
- In the presence of strong electromagnetic fields.

N.B.-:USE THE MACHINE UNDER "NORMAL" CLIMATIC CONDITIONS. IF YOU NEED TO USE THE MACHINE IN CLIMATIC CONDITIONS LIKELY TO CAUSE DETERIORATION (EXTREME : HUMIDITY, TEMPERATURES, SALINITY, CORROSIVENESS, ATMOSPHERIC PRESSURE), CONTACT HAULOTTE SERVICES®. REDUCE INTERVALS BETWEEN SERVICING.

N.B.-:IN HARSH ENVIRONMENTS (HIGH LEVELS OF SALINITY IN THE ATMOSPHERE: CLOSE TO THE SEA, INDUSTRIAL ENVIRONMENT WITH CHLORIDE EMISSIONS AND/OR HUMIDITY > 70%), WE RECOMMEND APPLYING SOLVENT-BASED OIL TO THE ENTIRE MACHINE.

N.B.-:WHILE THE MACHINE IS NOT IN USE, CARE MUST BE TAKEN TO BRING THE MACHINE TO THE FULLY STOWED POSITION. ENSURE THAT THE MACHINE IS LOCKED IN A SECURE LOCATION, AND THE CONTROL KEY IS REMOVED TO PREVENT UNAUTHORISED USE OF THE MACHINE.

B- Familiarization

1.2 - DECAL CONTENT

Decals are provided to alert the user of hazards inherent with the Aerial Work Platforms.

Decals provide the following information :

- The level of severity.
- The specific hazard.
- A method to avoid, suppress or reduce the hazard.
- Descriptive text (where required).

Familiarize yourself with the decals and the hazard severity levels.

Decals must be kept in good legible condition.

Familiarize yourself with the decals and their respective color codes.

Additional decals can be ordered from HAULOTTE Services®.

CE and AS standards



ANSI and CSA standards









Marking	Description
1	Hazard symbol
2	Level of severity
3	Avoidance symbol pictorial
4	Avoidance text

B- Familiarization









1.3 - SYMBOLS AND COLORS

Symbols and colors are used to alert the operator of safety precautions and/or to highlight important safety information.

The following safety symbols are used throughout this manual to indicate specific hazards and the hazard severity level when operating or maintaining the Aerial Work Platform.

Symbol	Description
	Danger : Risk of injury or death
	Caution : Risk of material damage
	Prohibited action
	Reminder to use good practice or follow pre-operation checks
	Cross-reference to another part of the manual
	Cross-reference to another manual
	Cross-reference to repair (contact HAULOTTE Services®)
N.B. :	Additional technical information

1.4 - LEVEL OF SEVERITY



































Color	Title	Description
		Danger : Indicates a hazardous situation which if not avoided, WILL result in death or serious injury.
		Warning : Indicates a hazardous situation which if not avoided, COULD result in death or serious injury.
		Caution : Failure to comply could result in minor or moderate injury.
		Notice : Indicates recommended practices if not followed, may result in a malfunction or damage the machine or its components.
		Procedure : Indicates a maintenance operation.

B- Familiarization

1.5 - SYMBOLS LEGEND AND DEFINITIONS

Symbols are used throughout this manual to depict hazards, avoidance measures and indicate when information is required.

Refer to the following table to familiarize yourself with these symbols.

Symbol	Description	Symbol	Description	Symbol	Description
	Body crushing hazard		Foot crushing hazard		High pressure fluid ejection hazard
			Hand crushing hazard		Entanglement hazard
			Health/safety hazards related to chemicals		Health-damaging effects from hot work environment
	Electrical contact or lightning strike		Burns and scalds from contact with flames, explosion or radiation from heat sources		Injury from Electric arcs - Energy supply disconnecting devices - Batteries fire, emissions, etc
	Risk of operator(s) falling		Tip over due to excessive loading / wind load and excessive ground slope		Relate and coordinate directional arrows on the chassis with those on the control box
	Do not put foot in this area		Do not put your hand in this area		Keep away from product working area
	Never expose batteries and electrical component to high pressure washer		Ensure entry drop rail is down		
	Flames prohibited		Maintain safe clearance from high voltage electrically charged conductors as described in manual - Do not use in thunderstorms		Overload
	Refer to operator manual		Safety belt		Use appropriate lanyard attached to dedicated anchor point.
	Wheel pressure		Enable switch		Use safety prop before attempting any maintenance work
	Tow point		Tie down point		Lift point
	Keep away from hot surfaces		Wear protective equipment		

B - Familiarization

2 - Models description

Regulations	Models
ANSI and CSA standards	HA100RTJ PRO
	HA130RTJ PRO
CE, AS and EAC standards	HA32RTJ PRO
	HA41RTJ PRO

A

B

C

D

E

F

G

H

I

B - Familiarization

3 - Primary machine components

3.1 - LAYOUT

HA32RTJ PRO - HA100RTJ PRO - HA41RTJ PRO - HA130RTJ PRO

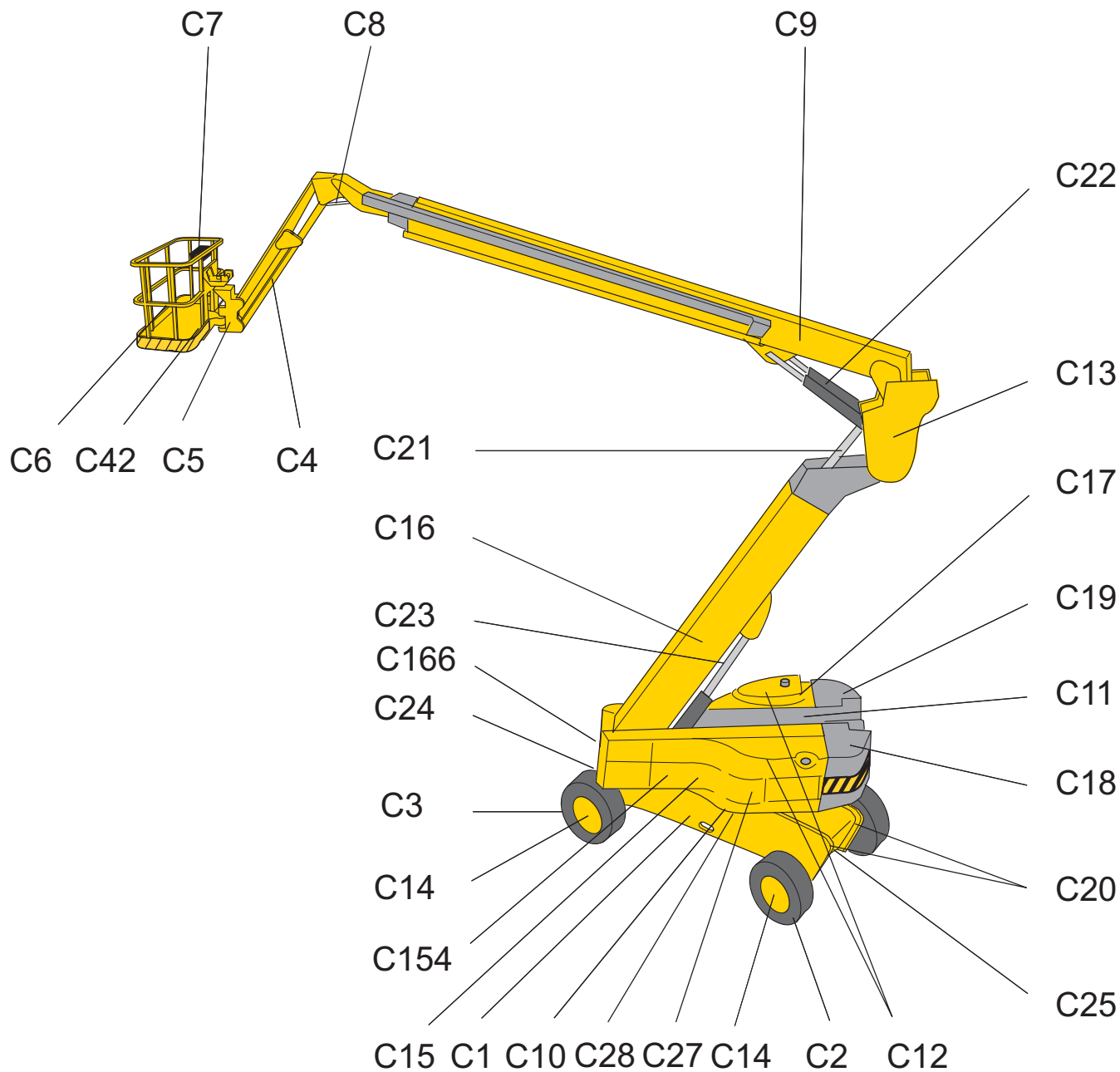

B- Familiarization

Marking	Description	Marking	Description
C1	Chassis	C17	Left side compartment (engine, pump and starter battery)
C2	Front driven steering axle	C18	Right counterweight
C3	Rear drive and/or steer wheel	C19	Left counterweight
C4	Jib	C20	Tie-down (and/or lifting) points
C6	Platform	C21	Link piece leveling cylinder
C7	Platform control box	C22	Boom lift cylinder
C8	Input jib leveling cylinder	C23	Arm lifting cylinder
C9	Upper boom	C24	Extendable fixed axle
C10	Slew ring	C25	Extendable swing axle
C11	Turntable assembly	C27	Ground control box + Universal plug
C12	Side cover	C28	Tilt sensor
C13	Arm/Boom link piece	C29	Platform rotation cylinder
		C35	Document holder
C14	Hydraulic drive motor and reducer	C42	Foot Switch
C15	Right side compartment (hydraulic oil tank and fuel tank)	C154	For Russia and the Ukraine only : Temperature probe relays
C16	Lower arm	C166	Axle extension control box

Universal plug



B - Familiarization

3.2 - GROUND CONTROL BOX

3.2.1 - Layout

General view

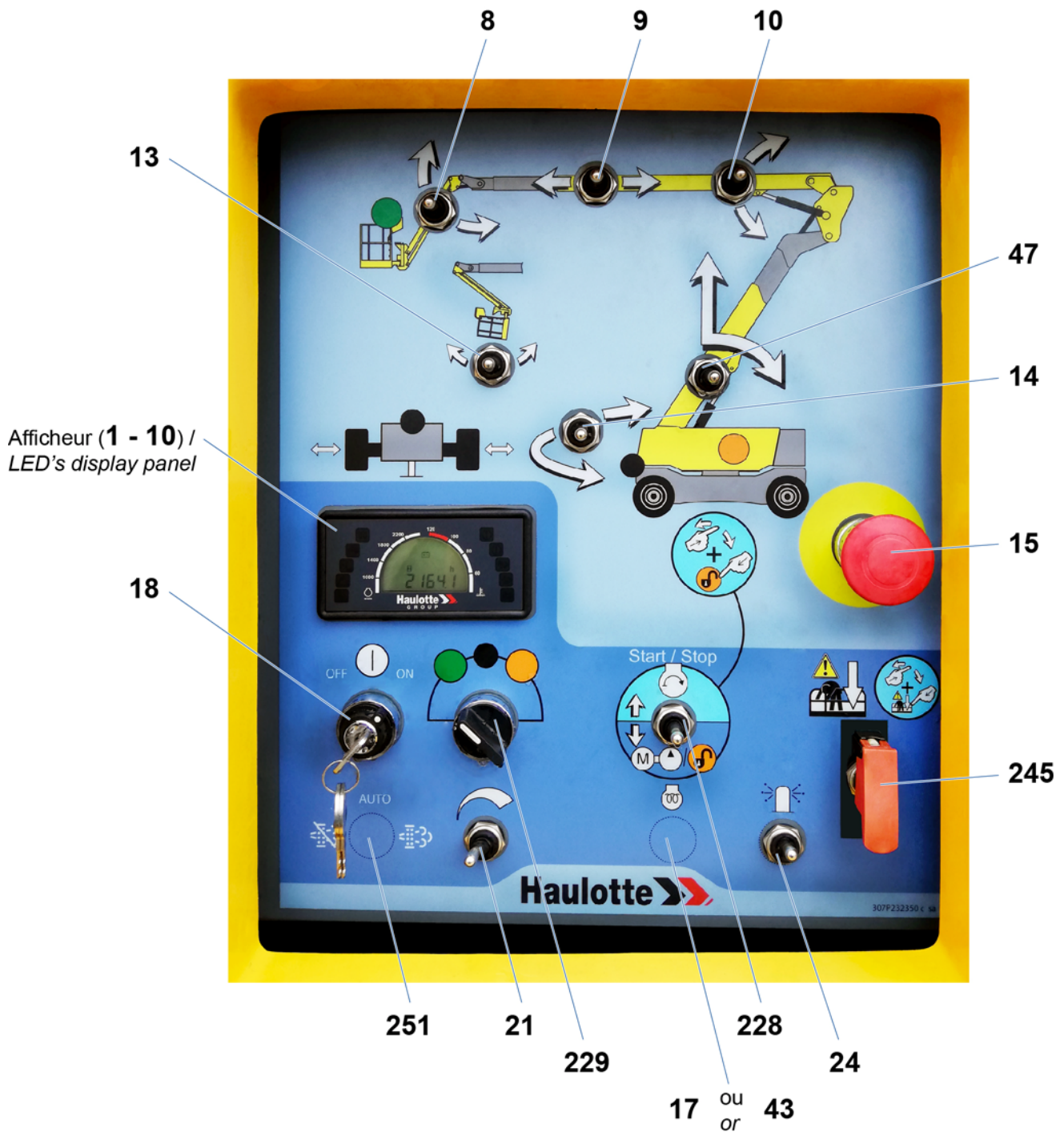

B- Familiarization

Controls and indicators

Marking	Name	Description	Function
8	SA620U	Jib lifting / lowering switch	Move upwards : Jib lifting
	SA620D		Move downwards : Jib lowering
9	SA530O	Boom telescoping switch	Move to the left : Boom extends
	SA530I		Move to the right : Boom retracts
10	SA520U	Boom raising switch	Move upwards : Boom raising
	SA520D		Move downwards : Boom lowering
13	SA720D	Basket levelling	Move to the right : Platform leveling lowered or placed in transport position
	SA720U		Move to the left : Platform leveling raised or placed in operating position
14	SA250L	Turntable rotation switch	Move to the left : Counter clockwise (CCW) rotation
	SA250R		Move to the right : Clockwise (CW) rotation
15	SB801	E-stop button	Pulled out : E-stop activated
			Pushed in : E-stop deactivated
17	SA301	Engine pre-heating selector ¹	Move downwards : Engine pre-heating
18	SA900	ON/OFF selector	ON : Power turned ON
			OFF : Power turned OFF
21	SA302	Engine revs selector	Move to the right : Engine speed increases
			Move to the left : Engine idle speed
24	SA903	Beacon light on/off ²	Move to the right : Beacon light on
			Move to the left : Beacon light off
43	SA907B	Horn button ³	Horn
47	SA420U	Arm telescoping or lifting selector	Move upwards : Telescope extension or arm lifting
	SA420D		Move downwards : Telescope retraction or arm lowering
228	SA905	Enable Switch / Back-up unit selector	Move upwards : Engine start
			Move downwards : Enable switch. If the engine is switched off, the emergency electropump is engaged automatically.
229	SA901	Control box energizing selector	Left : Platform control box energized
			Center : Axle extension box activation
			Right : Ground control box energized
245	SA801	"Overriding system" switch under cover	Emergency lowering system enabled when the cover is lifted. This must be used ONLY when normal operation from the ground box is unavailable - use in emergencies ONLY.
251	SA300	DPF ⁴	Diesel Particle Filter

1. For machines fitted with
2. For machines fitted with
3. For machines fitted with
4. For machines fitted with

B- Familiarization

3.2.2 - Display Panel (LED'S 1 - 10)







Indicators / Cluster



Marking	Description
LED 1	Overriding system : • Permanently lighted while the overriding switch is being used
LED 2	Fault : • Rapid flashing if a fault is active (current defect) • Flashing if the service counter is at zero
LED 3 ¹	Radius limitation • Flashing : Calibration fault or automatic reach limitation • Permanently lighted : Movement disabled by the reach limitation system
LED 4	Overload (For CE standard only) : • Rapid flashing : Faulty weighing system • Illuminated in case of overload
LED 5	Combustion engine pre-heating • Illuminated while engine is pre-heating • Off if engine started and if post-heating
LED 6	Engine warning • Flashing : 5 flashes when ignition is switched on if service counter is less than 20 hours • Constantly on : If the service counter is at zero
LED 7	Engine shutdown : • Lighted in case of major engine fault (e.g. engine overheating, oil pressure, alternator fault, etc.) • Lighted in case of faults managed by the engine ECU
LED 8	Not used
LED 9 ²	DPF regeneration required : • Permanently lighted if the particle filter requires regeneration with a high clogging level (DPF : Diesel Particulate Filter)
LED 10 ³	DPF regeneration in progress, high temperature in the exhaust system (HEST) (HEST : High Exhaust System Temperature)

1. If machine equipped with dual load
 2. If engine equipped with Particulate Filter Regeneration
 3. If engine equipped with Particulate Filter Regeneration

B- Familiarization

Symbol	Description
	Illuminated when service counter is displayed
	<ul style="list-style-type: none"> • Illuminated when engine is not running or when hour meter is displayed
	Low fuel level
	Illuminated when engine is not running, or if the engine is running and there is an alternator fault
	<p>Display of service counter for 3 s when the machine is switched on, then display of the hour meter for 3 s.</p> <p>Then :</p> <ol style="list-style-type: none"> 1. Display of one or more faults, if present, with scrolling of faults every 2 s 2. Display of service counter if it is at zero 3. Display of hour meter
	Indicates the engine speed
	<ul style="list-style-type: none"> • Indicates engine temperature, if available on the engine • All the bars flash if engine overheating

A

B

C

D

E

F

G

H

I

B- Familiarization

3.3 - PLATFORM CONTROL BOX

3.3.1 - Layout

General view

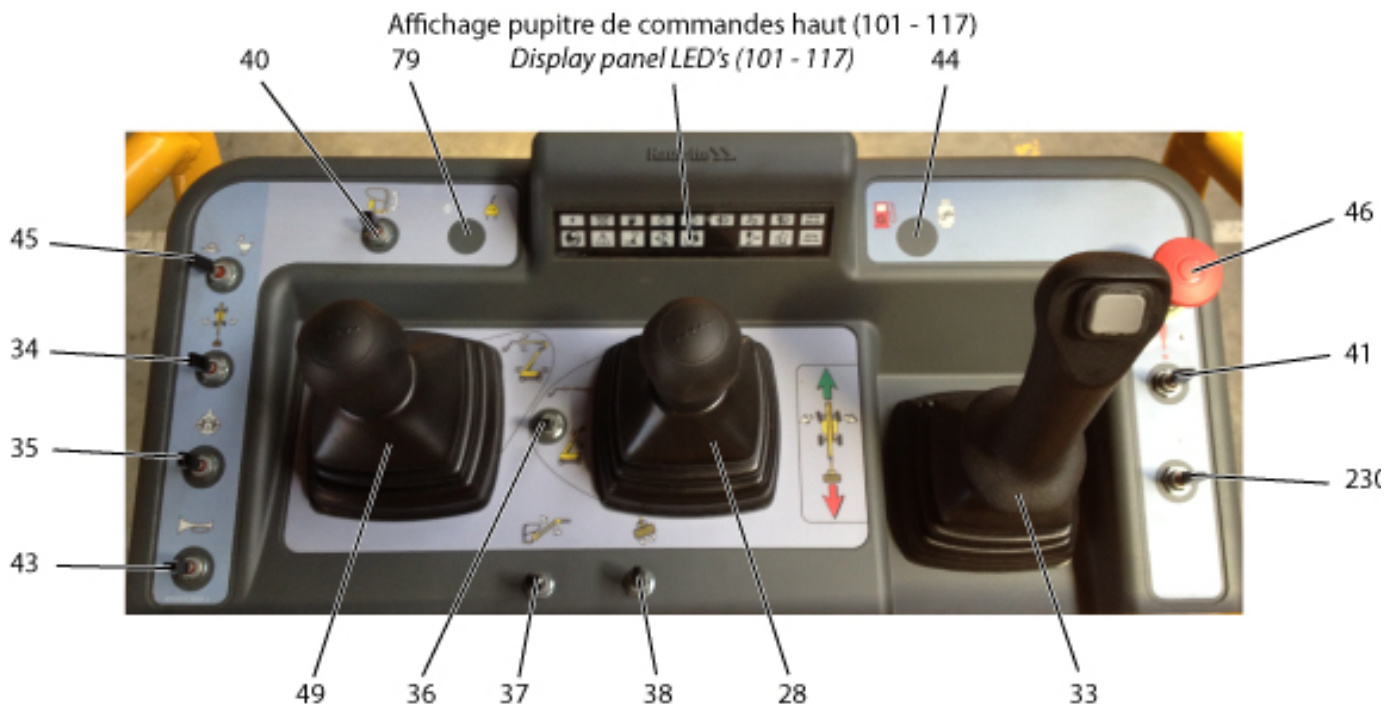

B - Familiarization

Controls and indicators

Marking	Name	Description	Function
28	SM901	Boom telescope or arm lifting/lowering joystick	Move forward : Boom retraction or arm lowering / Arm telescope retraction
			Move backwards : Boom extension or arm lifting / Arm telescope extension
33	SM902	Drive joystick	Move forward : Forward drive
		Front axle steering selector	Move backwards : Reverse drive
			Press right side of button : Right-hand steering
34	SA150	Rear axle steering selector	Press left side of button : Left-hand steering
			Move to the right : Right-hand steering
35	SA100	Differential lock selector	Move to the left : Left-hand steering
			Toggle and hold (activated) : Maximum drive torque (on difficult or sloping ground)
36	SA400	Boom or arm position selector	Release (deactivated) : Standard torque
			Up : Boom selection
37	SA621	Jib switch	Down : Arm selection
			Move upwards : Jib lifting
38	SA751	Platform rotation switch	Move downwards : Jib lowering
			Move to the right : Counter clockwise (CCW) rotation
40	SA721	Platform leveling switch	Move to the left : Clockwise (CW) rotation
			Move forward : Raise platform
41	SA800	Auxiliary power switch	Move backwards : Platform lowers
			Toggle and hold : Back-up unit activated
43	SA907	Horn button	Release : Back-up unit deactivated
			Horn
44	SA304	Fuel selector ¹	LPG : Propane Gas supply
			G : Petrol/Liquid propane gas or diesel supply
45	SA110	Drive speed selector	 High-speed drive
			 Low-speed drive
46	SB802	E-stop button	Pulled out : Platform control box energized
			Pressed in : De-energizes control system (Engine stopped)
49	SM900	Turntable rotation joystick	Move to the right : Counter clockwise (CCW) rotation
			Move to the left : Clockwise (CW) rotation
		Boom lift joystick	Move forward : Boom up
79	SA906	Generator selector ²	Move backwards : Lower boom
			Move to the left : Generator deactivated
230	SA303	Engine start-up / stop selector	Move to the right : Generator activated
			Start or stop the engine (depending on the machine's operating status) by moving the toggle switch

1. For machines fitted with

2. For machines fitted with

B- Familiarization

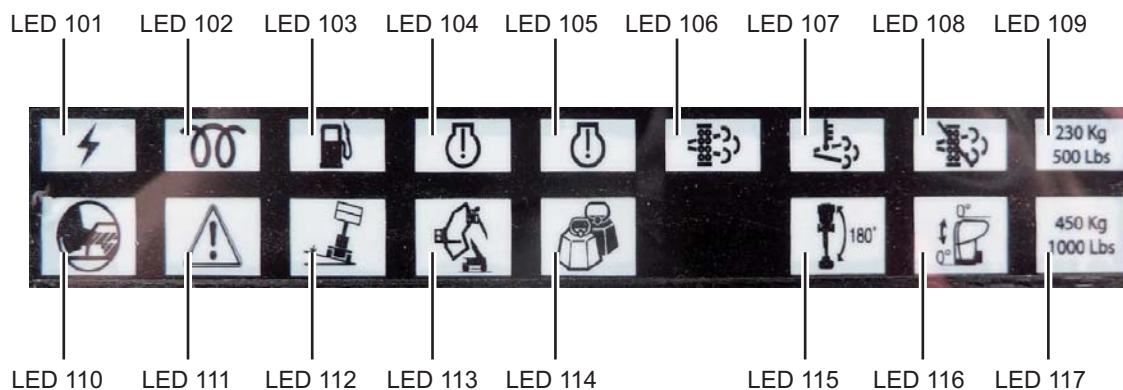

3.3.2 - Display Panel (LED'S 101 - 117)

Upper control box display

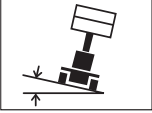

Marking	Name	Symbol	Function
LED 101	HL900		Power ON
LED 102	HL300		Combustion engine pre-heating
LED 103	HL307		Low fuel level
LED 104	HL304		Engine warning
LED 105	HL305		Engine shutdown
LED 106 ¹	HL301		DPF regeneration required
LED 107 ²	HL302		DPF regeneration in progress, high temperature in the exhaust system (HEST) (If equipped)
LED 108	HL303		Not used
LED 109 ³	HL805	230 kg 500 lbs	Not used
LED 110	HL807		Foot Switch
LED 111	HL801		Fault

B- Familiarization

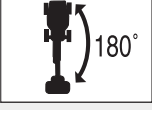
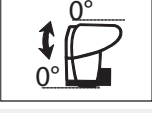
Marking	Name	Symbol	Function
LED 112	HL800		Tilt
LED 113	HL804		Not used
LED 114	HL802		Overload
LED 115	HL250		Turret at 180°
LED 116	HL720		Platform leveling
LED 117 ⁴	HL806	450 kg 1000 lbs	Not used

1. If engine equipped with Particulate Filter Regeneration
2. If engine equipped with Particulate Filter Regeneration
3. If machine equipped with dual load
4. If machine equipped with dual load

A

B

C

D

E

F

G







H

I

B- Familiarization

3.4 - DPF (DIESEL PARTICLE FILTER) (IF EQUIPPED - DEUTZ 2,2 TDC ENGINE ONLY)

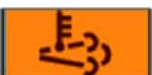
- The DPF (Diesel Particle Filter) system is designed to remove diesel particulate matter or soot from the exhaust gas of a diesel engine.
- The filter regeneration removes the accumulation of soot from the filter before filter clogs. This is done automatically by increasing the temperature in the filter itself in order to burn the soot.

Machine behaviour		Filter status - Soot loading level			
		Level 0	Level 1	Level 2	Level 3
Regeneration of diesel particles filter					
Engine derating					ON
Automatic regeneration mode			ON	ON	
Manual regeneration				ON	
Indicators					
Ground control box	Platform control box			Flashing	Flashing
	LED 111				
	LED 104				ON
	LED 105				ON
	LED 106			Flashing	Flashing
	LED 107			Flashing	Flashing
Sounding alarm					
 Ground control box				ON	ON
 Platform control box				ON	ON
Functions					
Automatic regeneration cut-out		✓	✓		
Movements are slowed down				ON	ON

B - Familiarization



3.4.1 - Automatic regeneration

The automatic regeneration occurs during normal machine usage without any interruption.

3.4.2 - Manual regeneration



The machine cannot be used during the manual regeneration cycle.

1. Park the machine in a safe stowed position outside location and away from other equipment.
2. Check that the fuel level icon on the ground control box doesn't light-up.
3. Put the engine hood in closed position.
4. Push the regeneration selector (251) on the ground control box to the right  and hold for 5 seconds.
5. When regeneration is initiated, the regeneration icon  on the ground control box starts blinking.
6. Engine speed increases to 2000 rpm.
7. The regeneration cycle will take approximately 40 min.
8. When regeneration is complete, all engine lights on the ground control box are turned off. Engine speed is automatically decreased to idle speed.

3.4.3 - To stop manual regeneration

Use this function only in case of emergency.

Regeneration process can be stopped by :

- Push the regeneration selector (251) to the left  and hold for 5 seconds.

Or

- Push the regeneration selector (251) to the right  and hold for 5 seconds.

Or

- Initiate any function movement.

A

B

C

D

E

F

G

H

I

B- Familiarization

3.5 - AXLE EXTENSION CONTROL BOX

3.5.1 - Layout

General view

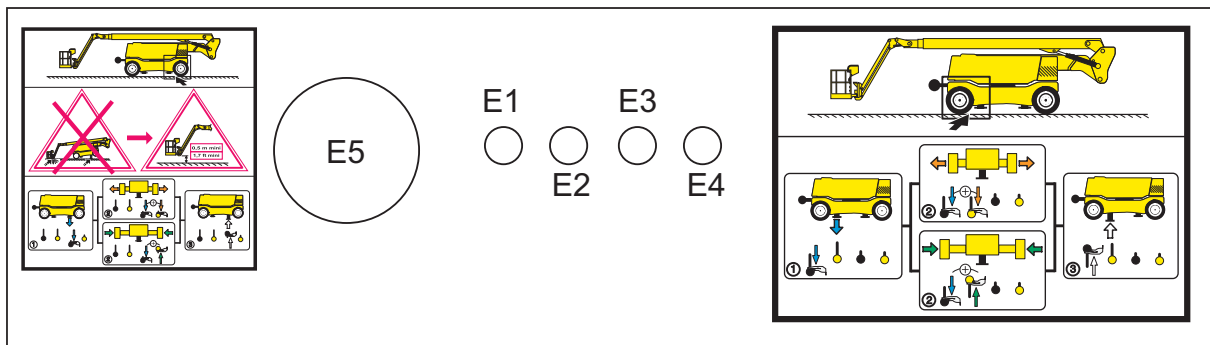

Controls and indicators

Marking	Function
E1	Outrigger cylinder lifting/lowering (chassis is lowered/raised) (Rear fixed axle)
E2	Fixed axle extension/retraction (Rear)
E3	Outrigger cylinder lifting/lowering (chassis is lowered/raised) (Front swing axle)
E4	Oscillating axle extension/retraction (Front)
E5	E-stop button

B - Familiarization

4 - Performance Specifications

4.1 - TECHNICAL CHARACTERISTICS

Use the table to select the right Haulotte machine for the job.



Do not replace parts that are essential to the stability of the machine, such as batteries or tyres, with parts that have a different weight or different specifications. The stability of the machine could be affected.

CE, AS, EAC, CSA and ANSI A92.20 standards

Machine	HA32RTJ PRO HA100RTJ PRO	
	SI	Imp.
Characteristics - Dimensions		
Maximum working height	31,80 m	104 ft 4 in
Maximum platform height	29,80 m	100 ft
Maximum horizontal reach	21,60 m	70 ft 10 in
Maximum outreach above the ground	21,10 m	69 ft 3 in
Maximum platform height before driving speed restriction	2,20 m	7 ft 3 in
Maximum boom articulation point height	11,40 m	37 ft 3 in
Turret rotation	360 °	
Platform rotation	180° (+90° / -90°)	
Jib working range	140° (+70° / -70°)	
Boom rotation angle	+70 / -40°	
Total weight	20200 kg	44,533 lbs
Maximum platform capacity	250 kg	550 lbs
Maximum number of occupants	2	
Maximum wind speed	60 km/h (16,7 m/s)	37 mph (58 ft/s)
Manual force	400 N - 90 lbf	
Gradeability - Forwards drive	40 %	
Gradeability - Reverse drive	40 %	
Maximum rated slope allowed	5°	
Maximum load on wheel	10260 kg	22,619 lbs
Maximum ground pressure of wheel on paved ground	10,8 daN/cm ²	22120 lb/ft ²
Drive speed :		
• Unfolded machine maximum speed - Micro-speed	0,5 km/h	0.3 m/h
• Folded machine maximum speed - High speed	5 km/h	3.1 m/h
Maximum freewheel speed during towed operation	5 km/h	3.1 m/h
Outside turning radius :		
• Axles retracted	5,07 m	16 ft 8 in
• Axles extended	5,74 m	18 ft 10 in
Inside turning radius :		
• Axles retracted	2,61 m	8 ft 6 in
• Axles extended	2,75 m	9 ft 0 in
Engine - Tier III		
Engine type	Perkins 1104D-44 Turbo	
Engine power	62 kW - 84 Hp	

B - Familiarization

Machine	HA32RTJ PRO HA100RTJ PRO
CO emission	0,89 g/kWh
HC + NO emission	4,24 g/kWh
Particles emission	0,27 g/kWh
Av fuel consumption :	230 g/kWh
• BSFC/CSE	10,7 L/h
• 70% power usage	55 kW
• Maximum power	
Fuel type	Diesel
Engine - Tier IV	
Engine type	Deutz 2,9 TCD
Engine power	55,5 kW - 74 Hp
CO emission	0,105 g/kWh
HC + NO emission	4,26 g/kWh
Particles emission	0,024 g/kWh
Av fuel consumption :	215 g/kWh
• BSFC/CSE	5,7L/h
• 70% power usage	55 kW
• Maximum power	
Fuel type	Diesel
Engine - STAGE V	
Engine type	Deutz 2,2 TCD
Engine power	55,4 kW - 74 Hp
CO emission	0,037 g/kWh
HC + NO emission	3,67 g/kWh
Particles emission	0,0051 g/kWh
Av fuel consumption :	210 g/kWh
• BSFC/CSE	5,6L/h
• 70% power usage	55,4 kW
• Maximum power	
Fuel type	Diesel
Specifications - Performance	
Operating temperature	- 20°C + 50°C (- 68°F / + 122°F)
Storage temperature	- 40°C + 70°C (- 104°F / + 158°F)
Energy storage	
Type of battery	12 V 135 Ah
Battery amperage	900 A
Battery voltage	12 V
Battery capacity	155 Ah
Hydraulic tank capacity	240 L (63 gal US)
Fuel tank capacity	140 L (37 gal US)

B- Familiarization

A

B

C

D

E

F

G

H

I

Machine	HA41RTJ PRO HA130RTJ PRO	
Characteristics - Dimensions	SI	Imp.
Maximum working height	41,50 m	136 ft 2 in
Maximum platform height	39,50 m	130 ft
Maximum horizontal reach	20,10 m	65 ft 11 in
Maximum outreach above the ground	19,60 m	64 ft 4 in
Maximum platform height before driving speed restriction	2,50 m	8 ft 3 in
Maximum boom articulation point height	17,50 m	57 ft 5 in
Turret rotation	360 °	
Platform rotation	180° (+90° / -90°)	
Jib working range	140° (+70° / -70°)	
Boom rotation angle	+70 / -40°	
Total weight	23880 kg	52,646 lbs
Maximum platform capacity	230 kg	500 lbs
Maximum number of occupants	2	
Maximum wind speed	45 km/h (12,5 m/s)	28 mph (41 ft/s)
Manual force	400 N - 90 lbf	
Gradeability - Forwards drive	40 %	
Gradeability - Reverse drive	40 %	
Maximum rated slope allowed	4°	
Maximum load on wheel	12650 kg	27,888 lbs
Maximum ground pressure of wheel on paved ground	13,2 daN/cm ²	27036 lb/ft ²
Drive speed :		
• Unfolded machine maximum speed - Micro-speed	0,5 km/h	0.3 m/h
• Folded machine maximum speed - High speed	5 km/h	3.1 m/h
Maximum freewheel speed during towed operation	5 km/h	3.1 m/h
Outside turning radius :		
• Axles retracted	5,07 m	16 ft 8 in
• Axles extended	5,74 m	18 ft 10 in
Inside turning radius :		
• Axles retracted	2,61 m	8 ft 6 in
• Axles extended	2,75 m	9 ft 0 in
Engine - Tier III		
Engine type	Perkins 1104D-44 Turbo	
Engine power	62 kW - 84 Hp	
CO emission	0,89 g/kWh	
HC + NO emission	4,24 g/kWh	
Particles emission	0,27 g/kWh	
Av fuel consumption :		
• BSFC/CSE	230 g/kWh	
• 70% power usage	10,7 L/h	
• Maximum power	55 kW	
Fuel type	Diesel	
Engine - Tier IV		
Engine type	Deutz 2,9 TCD	

B - Familiarization

Machine	HA41RTJ PRO HA130RTJ PRO
Engine power	55,5 kW - 74 Hp
CO emission	0,105 g/kWh
HC + NO emission	4,26 g/kWh
Particles emission	0,024 g/kWh
Av fuel consumption :	
• BSFC/CSE	215 g/kWh
• 70% power usage	5,7L/h
• Maximum power	55 kW
Fuel type	Diesel
Engine - STAGE V	
Engine type	Deutz 2,2 TCD
Engine power	55,4 kW - 74 Hp
CO emission	0,037 g/kWh
HC + NO emission	3,67 g/kWh
Particles emission	0,0051 g/kWh
Av fuel consumption :	
• BSFC/CSE	210 g/kWh
• 70% power usage	5,6L/h
• Maximum power	55,4 kW
Fuel type	Diesel
Specifications - Performance	
Operating temperature	- 20°C + 50°C (- 68°F / + 122°F)
Storage temperature	- 40°C + 70°C (- 104°F / + 158°F)
Energy storage	
Type of battery	12 V 135 Ah
Battery amperage	900 A
Battery voltage	12 V
Battery capacity	155 Ah
Hydraulic tank capacity	240 L (63 gal US)
Fuel tank capacity	140 L (37 gal US)

For China only :

HA32RTJ PRO - HA41RTJ PRO - Perkins Engine

环保信息标签	
达到 GB 20891-2014 第三阶段排放标准	
生产日期 : AA	
环保信息公开编号 : AB	
基本信息	型号 : AC
	名称 : 高空作业平台
	机械类型 : 工程机械
	机械生产企业名称 : 欧胜高空升降平台设备制造(常州)有限公司
	机械进口企业名称 : 欧历胜贸易(上海)有限公司
发动机型号 : AF	燃料喷射系统形式 : 泵喷嘴
发动机生产厂家名称 : 铂金斯	
环保关键零部件	ECU, 喷油泵, 喷油器, 排气消声器

B - Familiarization

4.2 - WORKING AREA / RANGE OF MOTION

HA32RTJ PRO - HA100RTJ PRO

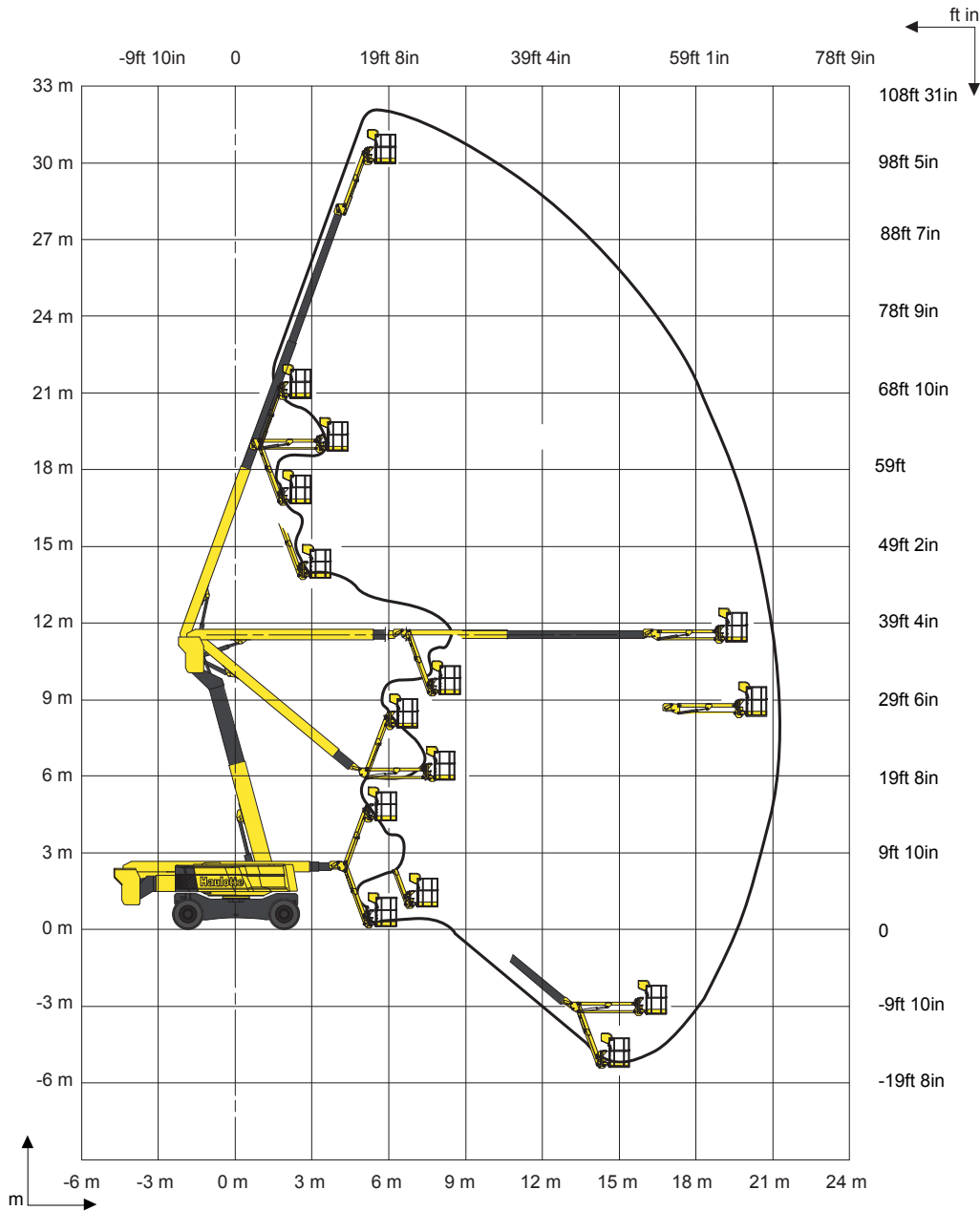

B- Familiarization

HA41RTJ PRO - HA130RTJ PRO

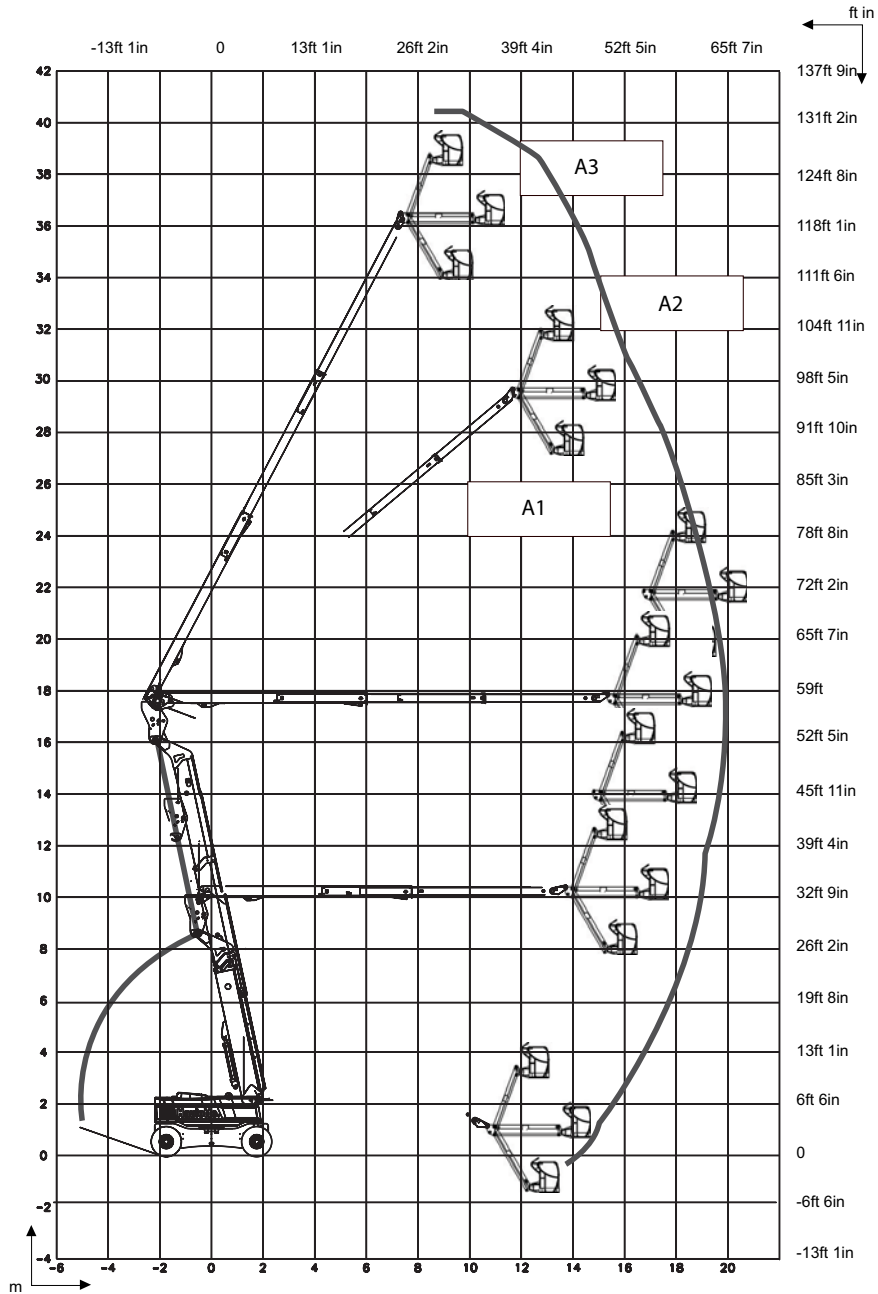

B - Familiarization

5 - Decals and markings locations

CE and AS standards - 4000204280 J - HA32RTJ PRO

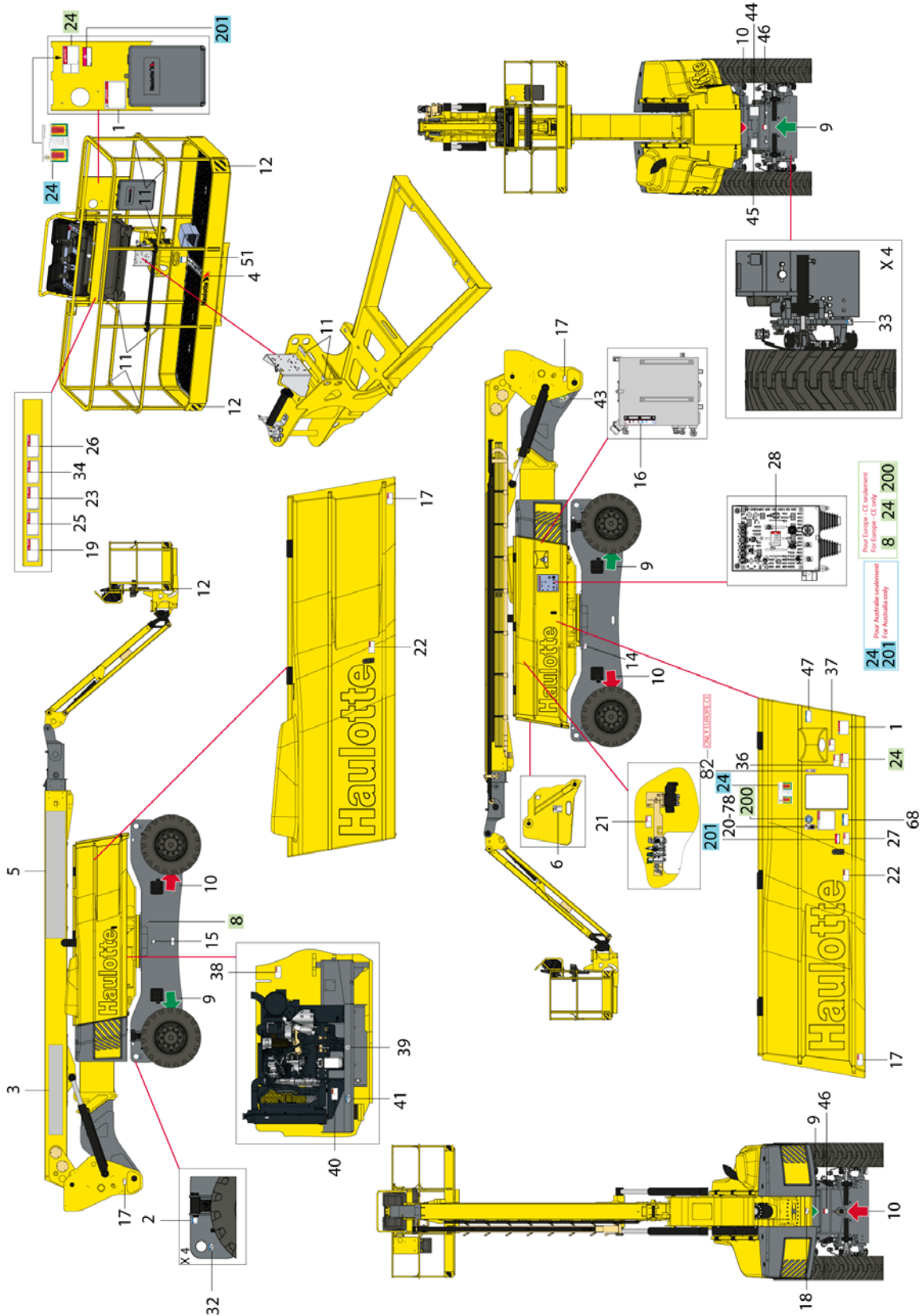

B- Familiarization

CE and AS standards : HA32RTJ PRO - HA41RTJ PRO

Marking	Color	Description	Quantity	HA32RTJ PRO	HA41RTJ PRO
1	Red	Height of the floor and load	2	4000701820	4000701830
2	Blue	Maximum Pressure per Tire - Floor Loading	4	4000204100	4000414290
3	Other	Commercial name - Bright machine	1	4000313270	4000364350
3	Other	Commercial name - Dark machine	1	4000313280	4000364340
4	Other	Small format HAULOTTE® logo - Bright machine	1	307P217080	
4	Other	Small format HAULOTTE® logo - Dark machine	1	307P224740	
4	Other	Small format HAULOTTE® logo - Red machine	1	307P220360	
5	Other	Large format HAULOTTE® logo - Bright machine	1	4000365570	
5	Other	Large format HAULOTTE® logo - Dark machine	1	4000390040	
5	Other	Large format HAULOTTE® logo - Red machine	1	4000390030	
6	Other	Identification plate	1	4000700160	
8	Other	Noise emission level	1	CE standard only 3078148740	
9	Other	Control of movements - GREEN directional arrow	4	3078143930	
10	Other	Control of movements - RED directional arrow	4	3078143940	
11	Other	Lanyard attachment points	9	307P216290	
12	Other	Material risk - Yellow and black adhesive tape	4	4000421700	
14	Red	Remove the blocking pin before rotating	1	4000027080	
15	Green	Greasing the turntable rotation gear	1	4000025160	
16	Other	Max and min oil level	1	4000044210	
17	Red	Risk of crushing	4	4000024800	
18	Orange	Hand crushing hazard - Risk of crushed hands	1	4000024890	
19	Red	Operation instructions	1	4000025140	

B- Familiarization

Marking	Color	Description	Quantity	HA32RTJ PRO	HA41RTJ PRO
20	Red	Operation instructions	1	In german (CE standard) : 307P222730 In english (CE and AS standards) : 307P222740 In chinese (CE standard) : 4000698920 In croatian (CE standard) : 4000360810 In danish (CE standard) : 307P222760 In spanish (CE standard) : 307P222770 In estonian (CE standard) : 4000360870 In finnish (CE standard) : 307P222780 In french (CE standard) : 3078149030 In greek (CE standard) : 4000561810 In dutch (CE standard) : 307P222790 In hungarian (CE standard) : 4000360890 In italian (CE standard) : 307P222800 In japanese (CE standard) : 4000359830 In latvian (CE standard) : 4000359840 In lithuanian (CE standard) : 4000359850 In norwegian (CE standard) : 4000359900 In polish (CE standard) : 4000359860 In portuguese (CE standard) : 307P222810 In romanian (CE standard) : 4000359870 In Russian (CE standard) : 4000359920 In slovakian (CE standard) : 4000359880 In slovenian (CE standard) : 4000359890 In swedish (CE standard) : 307P222820 In ukrainian (CE standard) : 4000359910	
21	Red	Prohibited use of the PVG	1	4000027070	
22	Orange	Wound foot - Do not place foot	2	4000027090	
23	Red	Risk of crushing - Driving direction	1	4000024690	
24	Red	Danger of electrocution	2	CE standard only : 4000025070 AS standard only : 4000227500	
25	Red	Risk of crushing - Closing drop rail	1	4000025080	
26	Red	Danger of electrocution - Ground for welding	1	4000027100	
27	Red	Verification of tilt operation	1	4000027110	
28	Red	Do not interchange	1	3078145180	
29	Red	Calibration	2	N/A	307P216930
32	Blue	Anchorage point - Traction	4	4000027310	
33	Blue	Anchorage point - Elevation	4	4000027330	
34	Red	Risk of electrocution - Water projection	1	4000025130	
36	Red	Risk of crushing - Platform	1	4000027460	
37	Red	Explosion hazard	1	4000027370	
38	Orange	Hand crushing hazard - Heat burns	1	4000027450	
39	Other	Oil CJ 4 (if fitted)	1	4000019700	
40	Orange	Hand crushing hazard - Fan	1	4000027430	
41	Yellow	Revolving cradle	1	3078151730	
43	Red	Arm compensation	1	307P223210	
44	Other	Oscillating axle extension/retraction	1	307P215120	

B- Familiarization

Marking	Color	Description	Quantity	HA32RTJ PRO	HA41RTJ PRO
45	Other	Fixed axle extension/retraction	1	3078153600	
46	Red	Maximum effort on the stabilizers	2	307P219880	
47	Blue	Information - Explanation - LOW SULFUR - For Tiers IV only	1	307P232480	
51	Yellow	Socket - 240 V	1	4000027120	
68	Other	Transport height	1	4000417500	4000417510
78	Other	QR Code ( https://www.e.technical-information.com)	1	4001089310	
82	Other	Regeneration of diesel particles filter (STAGE V engine only)	1	CE standard only 4001075370	
200	Other	"Made in Europe"	1	CE standard only : 4000137690	
201	Red	Wearing of a safety harness is essential	2	AS standard only : 3078144520	
Not shown	Other	Working area / Range of motion	1	4000507800	4000507910

A

B

C

D

E

F

G

H

I

B- Familiarization



Notes

B - Familiarization

EAC standard - 4000205430 I - HA32RTJ PRO

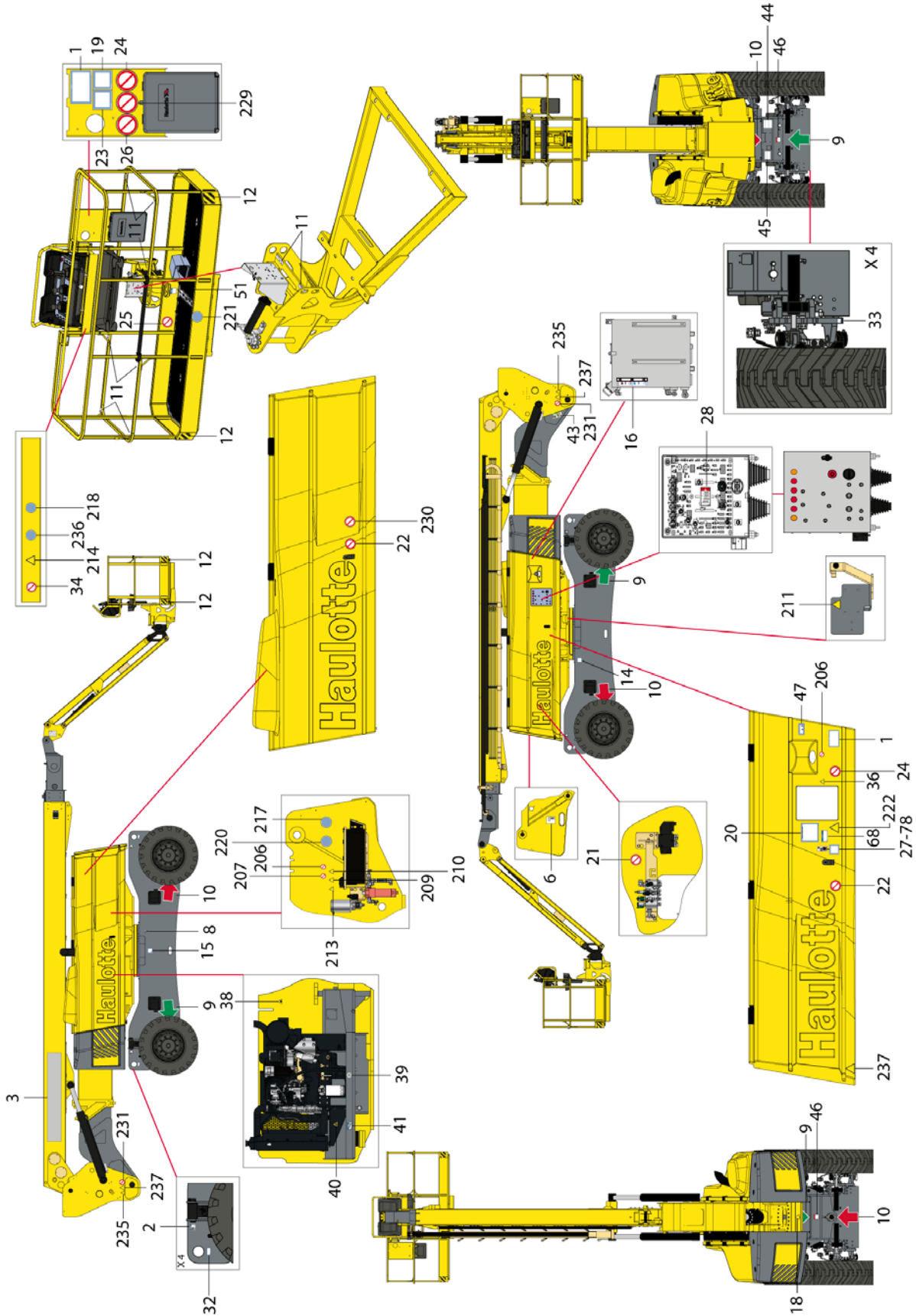

B - Familiarization

EAC standard - 4000209840 G - HA41RTJ PRO

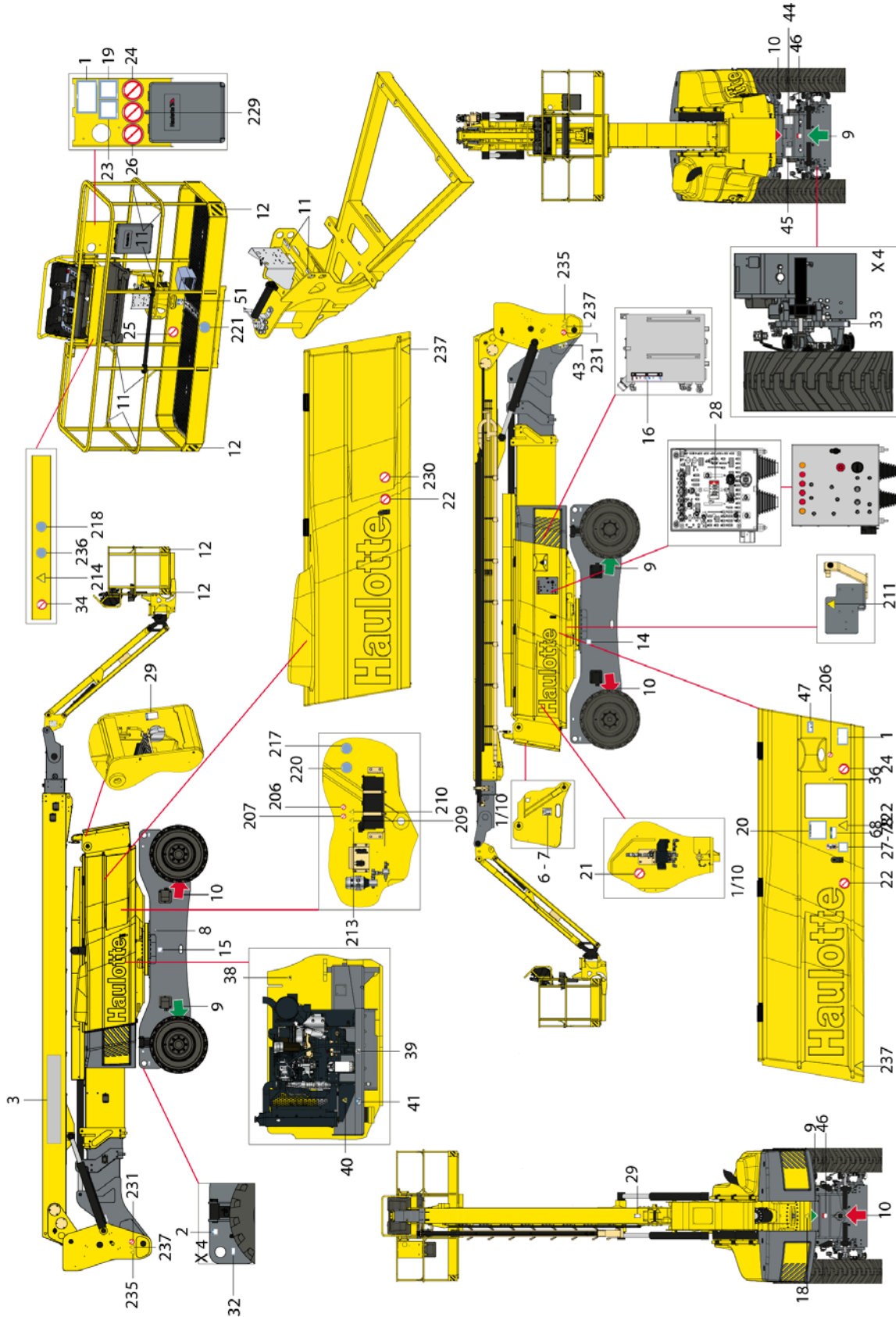

B - Familiarization

EAC standard

Marking	Color	Description	Quantity	HA32RTJ PRO	HA41RTJ PRO
1	Red	Height of the floor and load	2	4000011950	4000011990
2	Blue	Maximum Pressure per Tire - Floor Loading	4	4000204100	4000414290
3	Other	Commercial name - Bright machine	1	4000313270	4000364350
3	Other	Commercial name - Dark machine	1	4000313280	4000364340
6	Other	Identification plate	1	For Russia : 4000278870 For Ukraine : 307P227830	
8	Other	Noise emission level	1	3078148740	
9	Other	Control of movements - GREEN directional arrow	4	3078143930	
10	Other	Control of movements - RED directional arrow	4	3078143940	
11	Blue	Lanyard attachment points	9	307P216290	
12	Other	Material risk - Yellow and black adhesive tape	4	4000421700	
14	Red	Remove the blocking pin before rotating	1	307P227810	
15	Green	Greasing the turntable rotation gear	1	307P227020	
16	Other	Max and min oil level	1	4000044210	
18	Yellow	Hand crushing hazard - Risk of crushed hands	1	307P227660	
19	Blue	Operation instructions	1	For Russia : 307P227190 For Ukraine : 307P227840	
20	Red	Operation instructions	1	For Russia : 4000359920 For Ukraine : 4000359910	
21	Red	Prohibited use of the PVG	1	4000079680	
22	Red	Wound foot - Do not place foot	2	307P227010	
23	Blue	Risk of crushing - Driving direction	1	307P227040	
24	Red	Danger of electrocution	2	307P226960	
25	Red	Risk of crushing - Closing drop rail	1	307P226950	
26	Red	Danger of electrocution - Ground for welding	1	307P226970	
27	Blue	Verification of tilt operation	1	For Russia : 307P227060 For Ukraine : 307P227870	
28	Red	Do not interchange	1	3078145180	
29	Red	Calibration	2	N/A	307P216930
32	Blue	Anchorage point - Traction	4	4000135970	
33	Blue	Anchorage point - Elevation	4	4000135960	
34	Red	Electric Shock Hazards - Water projection	1	307P226780	
36	Yellow	Risk of crushing - Platform	1	4000014290	
38	Yellow	Hand crushing hazard - Heat burns	1	4000200810	
39	Other	Oil CJ 4 (if fitted)	1	4000318680	
40	Yellow	Hand crushing hazard - Fan	1	307P226940	
41	Yellow	Revolving cradle	1	307P215290	

B- Familiarization

Marking	Color	Description	Quantity	HA32RTJ PRO	HA41RTJ PRO
43	Red	Arm compensation	1	307P223210	
44	Other	Oscillating axle extension/retraction	1	307P215120	
45	Other	Fixed axle extension/retraction	1	3078153600	
46	Red	Maximum effort on the stabilizers	2	307P219890	
47	Blue	Information - Explanation - LOW SULFUR	1	For Russia : 4000416640 For Ukraine : 4000416650	
51	Yellow	Socket - 240 V	1	4000027120	
68	Other	Transport height	1	4000417500	4000417510
78	Other	QR Code ( https://www.e.technical-information.com)	1	4001089310	
206	Red	Flames prohibited	2	307P226750	
207	Red	Smoking forbidden	1	307P226760	
209	Yellow	Battery danger	1	307P226790	
210	Yellow	Fire Hazard	1	307P226800	
211	Yellow	Electrical danger	1	307P226810	
213	Yellow	Corrosion hazard	1	307P226830	
214	Yellow	Danger unstable side	1	307P226930	
217	Blue	Caution glasses	1	307P227460	
218	Blue	Caution helmet compulsory	1	307P226680	
220	Blue	Hand protection compulsory	1	307P227490	
221	Blue	Obligatory routing	1	307P227510	
222	Yellow	Danger unstable side	1	307P227680	
229	Red	Do not travel down slopes in high speed	1	307P226990	
230	Red	No admittance to unauthorized persons	1	307P227560	
231	Red	Do not park in the work area	2	307P227000	
235	Yellow	Vertical crushing of the body	2	4000014270	
236	Blue	Caution glasses	1	307P226670	
237	Yellow	Risk of crushing	3	307P227670	
Not shown	Other	Working area / Range of motion	1	4000507800	4000507910

B - Familiarization

ANSI and CSA standards - 4000204300 K - HA100RTJ PRO

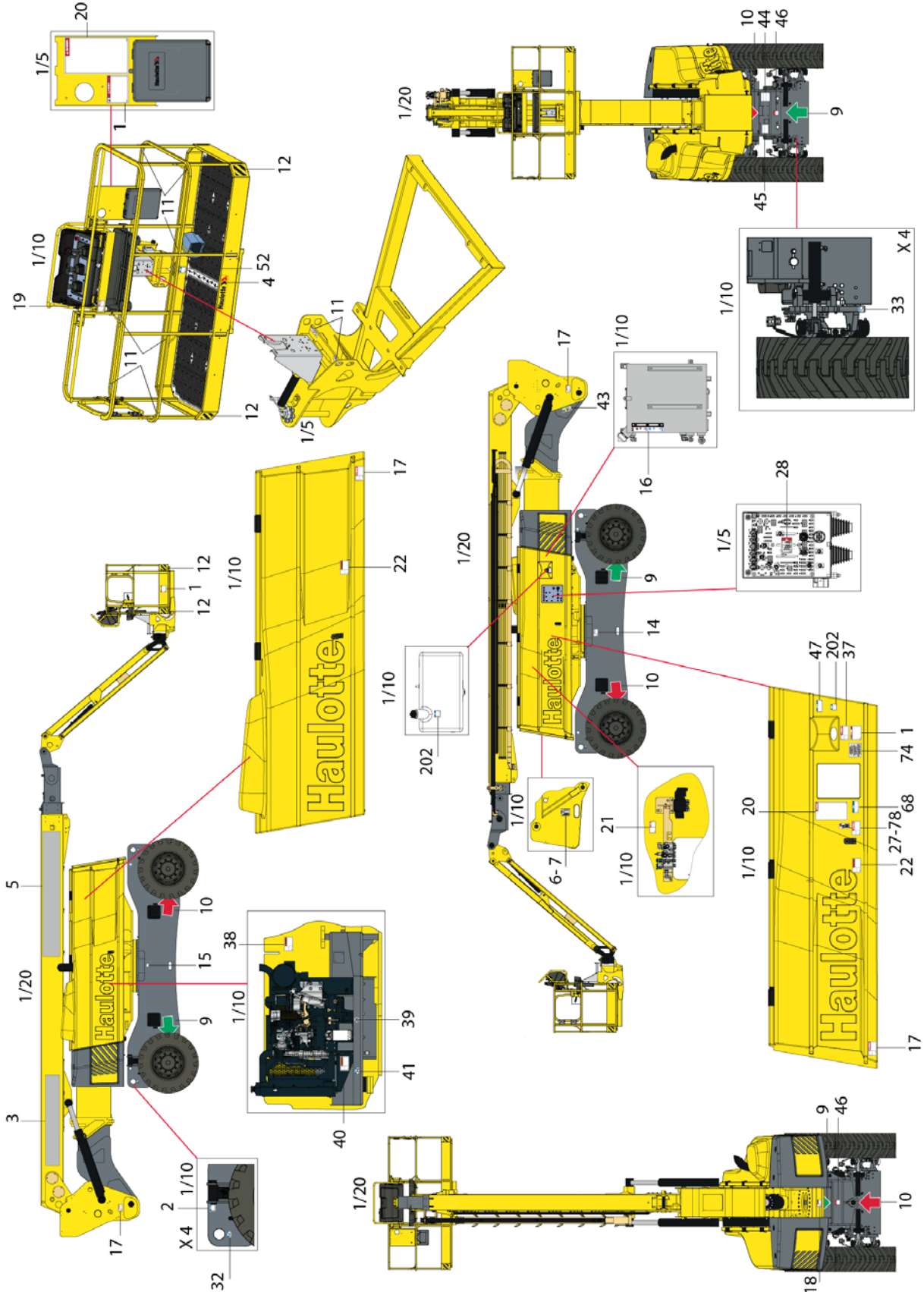

B - Familiarization

ANSI and CSA standards - 4000202980 I - HA130RTJ PRO

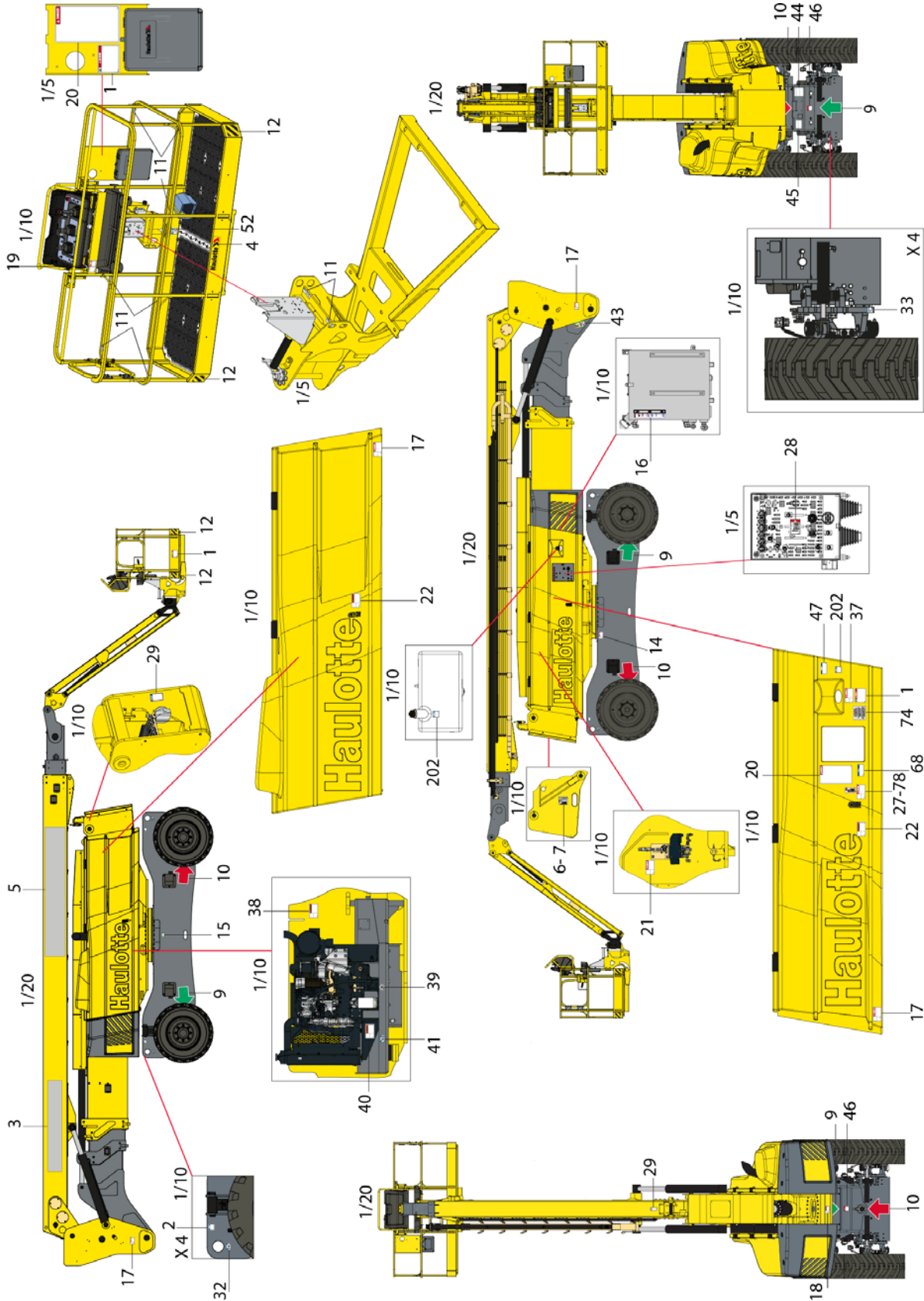

B - Familiarization

ANSI and CSA standards

Marking	Color	Description	Quantity	HA100RTJ PRO	HA130RTJ PRO
1	Red	Height of the floor and load - Single load machine	3	4000701820	4000701830
2	Blue	Maximum Pressure per Tire - Floor Loading	4	4000204100	4000414290
3	Other	Commercial name - Bright machine	1	4000364330	4000364370
3	Other	Commercial name - Dark machine	1	4000364320	4000364400
4	Other	Small format HAULOTTE® logo - Bright machine	1	307P217080	
4	Other	Small format HAULOTTE® logo - Dark machine	1	307P224740	
4	Other	Small format HAULOTTE® logo - Red machine	1	307P220360	
5	Other	Large format HAULOTTE® logo - Bright machine	1	4000365570	
5	Other	Large format HAULOTTE® logo - Dark machine	1	4000390040	
5	Other	Large format HAULOTTE® logo - Red machine	1	4000390030	
6	Other	Identification plate	1	4000700170	
9	Other	Control of movements - GREEN directional arrow	4	3078143930	
10	Other	Control of movements - RED directional arrow	4	3078143940	
11	Other	Lanyard attachment points	9	307P216290	
12	Other	Material risk - Yellow and black adhesive tape	4	4000421700	
14	Red	Remove the blocking pin before rotating	1	In english : 4000024830 In french : 4000068080 In spanish : 4000086510	
15	Green	Greasing the turntable rotation gear	1	4000025160	
16	Other	Max and min oil level	1	4000044210	
17	Red	Risk of crushing	4	In english : 4000024640 In french : 4000067680 In spanish : 4000086460	
18	Orange	Hand crushing hazard - Risk of crushed hands	1	In english : 4000024770 In french : 4000067710 In spanish : 4000086490	
19	Red	Operation instructions	1	4000025140	
20	Red	Operation instructions	2	In english : 4000027570 In french : 4000068880 In spanish : 4000086640	
21	Red	Prohibited use of the PVG	1	In english : 4000024820 In french : 4000067690 In spanish : 4000086470	
22	Orange	Wound foot - Do not place foot	2	In english : 4000024840 In french : 4000068180 In spanish : 4000086610	

B- Familiarization

Marking	Color	Description	Quantity	HA100RTJ PRO	HA130RTJ PRO
27	Red	Verification of tilt operation	1	In english : 4000024860 In french : 4000068090 In spanish : 4000086520	
28	Red	Do not interchange	1	3078145180	
29	Red	Calibration	2	N/A	307P216930
32	Blue	Anchorage point - Traction	4	4000027310	
33	Blue	Anchorage point - Elevation	4	4000027330	
37	Red	Explosion hazard	1	In english : 4000025010 In french : 4000068130 In spanish : 4000086560	
38	Orange	Hand crushing hazard - Heat burns	1	In english : 4000025040 In french : 4000068110 In spanish : 4000086540	
39	Other	Oil CJ 4 (if fitted)	1	4000019700	
40	Orange	Hand crushing hazard - Fan	1	In english : 4000025020 In french : 4000068100 In spanish : 4000086530	
41	Yellow	Revolving cradle	1	3078151730	
43	Red	Arm compensation	1	307P223210	
44	Other	Oscillating axle extension/retraction	1	307P215120	
45	Other	Fixed axle extension/retraction	1	3078153600	
46	Red	Maximum effort on the stabilizers	2	307P219880	
47	Blue	Information - Explanation - LOW SULFUR	1	307P232480	
52	Blue	Socket - 110 V	1	4000027590	
68	Blue	Information-Transport height	1	4000417500	4000417510
74	Other	California warning - P65	1	4001026850	
78	Other	QR Code ( https://www.e.technical-information.com)	1	4001089310	
202	Blue	Diesel Fuel Only	2	4000201430	

C - Pre-operation inspection

1 - Recommendations

The owner, the site manager, the supervisor and the operator are all responsible to ensure the machine is fit for the work it is to perform; i.e. that the machine is suitable to carry out the work in complete safety and in compliance with this Operator's Manual. All managers who are responsible for persons operating the machine must be familiar with the local regulations currently applicable in the country of use and ensure that they are adhered to.

Before using the machine, read the previous chapters in this manual. Ensure that you have understood the following points :

- Safety precautions.
- Operator's responsibilities.
- Conditions and the operating principles of the machine.

2 - Working area assessment

Before carrying out any operations, ensure that the machine corresponds to the work to be done and the working environment :

- Carry out a thorough inspection of the site to identify any potential risks within the work zone.
- Take the necessary precautions to avoid collisions with other machinery within the work zone.

Ensure that :

- The weather conditions (wind, rain, etc.) allowing the machine to be used.
- The ground withstands the weight of the machine and has not been affected by the poor weather conditions.
- Check that the authorisations to work with the machine on the site in question have been obtained (.g. chemical product factories).
- Define a rescue plan for all the risks, including the risk of falls and crushing.

C - Pre-operation inspection

3 - Inspection and Functional test

3.1 - DAILY INSPECTION

Each day before the beginning of a new work session and with each change of operator, the machine must be subjected to a visual inspection and a complete functional test.



- Never use a defective or a malfunctioning aerial work platform.
- If any item on the check list is marked "No" during the inspection; machine must be tagged and placed out of service.
- Do not operate the machine until all identified items are corrected and it has been declared safe for operation.

In case of loose fasteners, refer to torque table value in maintenance book.

In case of leaks, replace the damaged part before use.

In case of structural part deformation (cracks, broken weld, paint chips) replace the part before use.



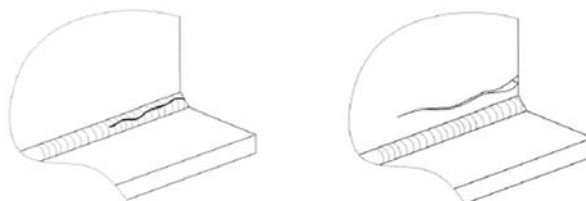





Sample of broken welds



We recommend these forms to be completed daily and stored to assist with your maintenance schedule.

















Each action is depicted in the daily inspection sheet using the following symbols.

Use the detailed program below.

	Oil change		Lubrication-Lubrication		Tightening
	Levelling		Systematic replacement		Functional adjustments / Checks / Cleaning
	Visual inspection		To check by test		

Serial number :	Model :
Hours of operation :	
HAULOTTE Services® contract reference :	
Intervention record number :	
Date :	
Name :	
	Signature :

C - Pre-operation inspection

	Page or associated procedure	Daily	OK	NOK	Corrected	Comments
Chassis assembly : Wheel, reducer, steering, wheel pivot						
Check state of tires/tyres and inflations						
Thermal engines						
Check engine fuel level (Top up the oil if necessary)						
Check engine oil level (Top up the oil if necessary)						
No leaks from engine components (engine, hoses, radiator)						
Check the condition of the battery						
Check the cooling circuit level (Top up the oil if necessary)						
Check the operation of the lock on the engine casing						
Check and clean the element of the air filter if necessary						
Clean the fuel filter						
Turntable						
Test the operation of the turntable locking system						
Hydraulic : oils, filters and hoses						
Check the hydraulic oil level (Top up the oil if necessary ; Machine stowed)						
Check the clogging indicator on the hydraulic pressure filter (change if clogged)						
Check the hoses, blocks and pumps, fittings, cylinders and the tank for the absence of leaks, deformations and damage						
Platform						
Ensure that the gate or sliding bar shall be designed to either return automatically to the closed and latched position						
Check that the harness anchor points are not cracked or damaged						

A

B

C

D

E



















F

G

H

I

C - Pre-operation inspection

	Page or associated procedure	Daily	OK	NOK	Corrected	Comments
General						
Check for the presence, cleanliness and readability of the manufacturer's plates, security labels, user manual and maintenance manual						
Check the cleanliness and readability of the control box						
Test the opening and closure of covers (chassis, turntable, upper control box)						
Check the condition of electrical harnesses, cables and connectors						
Check for the absence of abnormal noise and jerky movements						
Check for the absence of visible deterioration and damage						
Check for the absence of cracks, broken welds and chipped paintwork on the structure						
Check for the absence of missing or loose screws and bolts						
Check for the absence of deformation, cracking and breakage of axis stops, bushing and axes						
Check for the absence of foreign bodies in joints and sliding parts						
Safety devices						
Test the operation of the upper and lower control boxes: manipulators, switches, buttons, horn, emergency stops, screens and lights						
Test the operation of visual and audible alarms						
Test the operation of the tilt system						
Test the operation of the emergency lowering system						
Test the operation of the axle locking system						
Test the operation of the loading control system (visual alarm on the control box)						
Test the operation of the Activ Shield Bar (if equipped)						

C - Pre-operation inspection

4 - Safety functional checks

To protect the user and the machine, safety systems prevent the movement of the machine beyond its operating limits. These safety systems when activated immobilize the machine and prevent further movement.

The operator must be familiar with this technology and understand that is not a malfunction but an indication that the machine has reached an operation limit.

Aerial Work platforms are equipped with two control boxes which allow operators to safely use the machine. An auxiliary system (Overriding system) is available on the ground control box in order to rescue anyone trapped on the platform.

The following checks describe the operation of the machine and the specific controls required.

For the location and description of these controls :  refer to section B 3.2 and D 2 - Ground control box and B 3.3 and D 3 - Platform control box.

A

B

C

D

E

F

G

H

I

C - Pre-operation inspection

4.1 - E-STOP BUTTON CHECK

Ground control box E-stop button

Step	Action
1	Pull both E-Stop buttons (15) at ground box and (46) at platform box.
2	Set the ON/OFF key switch (18) at ground box to the ON position.
3	Turn the selector switch (229) knob to the right to energize the ground control box. LED's (1 - 10) on the display will light up.
4	Start the engine by moving the Enable/auxiliary power Switch (228) upwards.
5	Push the E-stop button (15).
6	Check that the engine stops running.
7	No movements are functional.

Platform control box E-stop button

Step	Action
1	Pull out the E-Stop button (15) at ground box.
2	Set the ON/OFF key switch (18) at ground box to the ON position.
3	Turn the selector switch knob (229) at ground box to the left to energize platform box.
4	Pull out the E-Stop button (46) at platform box.
5	Start the engine from platform using Start/Stop switch (230).
6	Push in E-Stop button (46) at platform.
7	Check that the engine stops running.
8	No movements are functional.

Axle extension control box E-Stop button

Step	Action
1	Pull the E-stop buttons(15, 46, E5).
2	Set the ON/OFF key switch (18) to ON position.
3	Turn the control box activation selector switch (229) to the centre to activate the axle control box. The indicators light up.
4	Push the E-stop button (E5). The indicators go out.

C - Pre-operation inspection

4.2 - ACTIVATION OF CONTROLS

The enable foot pedal (enable switch) must be activated to allow any movement.

The "Enable Switch" system depends on the machine configuration and will consist of one of the following :

- Joystick trigger at platform box (if fitted).
- Foot pedal (enable switch) in the platform (Optional).
- Enable switch at ground box.

4.3 - FAULT DETECTOR

The machine is equipped with an on-board fault detection system, which indicates the type of fault to the operator.

The fault is identified by a default code.

The default code is displayed at the ground control box.

According to the type of fault, the machine MAY switch into DOWNGRADEMODE mode and certain movements are prevented to maintain Operator's safety.

Do not use the machine until the fault has been corrected.

4.3.1 - Indicators/LED's test

From the ground control box

Step	Action
1	Pull both the E-Stop buttons (46) at platform box and (15) at ground box.
2	Set the ON/OFF key switch (18) to ON position.
3	Check that the LED's (1 - 10) light up on the display box.
4	Check that the LED's on the display are all turned off after 1 sec.

From the platform control box

Step	Action
1	Pull E-Stop button (15) at ground box.
2	Turn the ON/OFF key switch (18) at ground box to ON position.
3	Turn the energizing selector switch (229) to the left to energize platform control box.
4	First push in the E-Stop button (46) at platform box, then pull out.
5	Check that the LED's (101 - 117) light up on the platform display panel.
6	Check that the LED's (101 - 117) on the display are all turned off after 1 sec.

C - Pre-operation inspection

4.3.2 - Buzzers test

From the ground control box

Step	Action
1	Pull both E-Stop buttons (15) at ground box and (46) at platform box.
2	Set the ON/OFF key switch (18) to ON position.
3	Buzzers at ground and platform will beep.

4.4 - AUTOMATIC ENGINE CUT-OUT

The engine automatically cuts out in the following conditions :

- The alternator is not functioning.
- Engine temperature is too high.
- Oil pressure is too low.
- The E-stop(s) is (are) pushed in.
- The machine is switched off.

4.5 - OVERLOAD SENSING SYSTEM

If the platform load exceeds the maximum allowed load, no movement is possible from the 2 control boxes.

At ground and platform control boxes a buzzer sounds and an indicator light warns the operator

To return the machine to normal operation remove weight from the platform until the load is below the maximum allowed load.

Daily check that the LED's illuminate when the machine is switched on :

- Verify that the Overload system is active : Refer to Indicators (6) at ground and (30) at platform.
- Verify that the buzzers are functioning : Refer to Buzzers test

A periodic inspection of this device must be performed according to the recommendation in Maintenance Schedule.

4.6 - OSCILLATING AXLES

To improve the driving capability on rough terrain, the front axle is equipped with an oscillating mechanism. When the extending structure is retracted and is in the stowed position, oscillating mechanism is unlocked to adapt itself to the features of ground operation. When the extending structure is out of the stowed position, a safety device locks the oscillating mechanism to reduce overturning hazard.

A visual inspection must be performed periodically to ensure the absence of leaks from the oscillating cylinder and associated plumbing connections including the hydraulic hoses.

A periodic inspection of this device must be conducted according to the recommendation in the maintenance schedule.

C - Pre-operation inspection

4.7 - SLOPE WARNING DEVICE

From each control box, a buzzer alerts the operator that the machine is not folded/stowed and is positioned on a slope exceeding the slope allowed.

On slope, as long as the extendable structure is out of the stowed position, the drive is forbidden (All standards except ANSI A92.6).

All movements are allowed.

In this case, fully lower the platform and reposition the machine on level ground before raising the platform again.

To restore the drive function, perform the sequences of following movements :

1. Completely retract the boom.
2. Lower the boom.
3. Lower the arm.

To check the tilt sensor at ground control box

Step	Action
1	Open the right hand compartment cover (component location diagrams) and locate the tilt sensor (C28) on the left side of the ground control box.
2	Pull both E-Stop buttons; (15) at ground box and (46) at platform box.
3	Set the ON/OFF key (18) switch to ON position.
4	Turn the selector switch (229) knob to the right to energize ground control box.
5	Start the engine by moving the Enable/auxiliary power Switch (228) upwards.
6	Stow the telescoping boom by actuating the boom raise/lower switch (10), boom telescope switch (9) and arm lifting switch (47).
7	While manually tilting the sensor (228), move it towards the front and hold.
8	Raise the boom to more than 10 degrees above horizontal using the raise/lower switch (10).
9	Check that the audible beep sounds and the movement is slowed.

4.8 - TRAVEL SPEED LIMITATION

The machine has a selector of 2 driving speeds - low and high.

All driving speeds are enabled when the machine is not elevated. Adjust position of Jib (if equipped) to enhance field of vision during driving.

Whatever the position of the drive speed selector switch (45) on the platform control box, the drive speed is limited when the machine is unfolded.

Daily check that the speed is limited to less than 1 km/h (0.6 mph) when :

- The boom is raised by more than 10° above horizontal.
- The boom is telescoped/extended more than 400 mm (16 in).
- The arm is raised by more than 2 m (6 ft 7 in) above horizontal.

C - Pre-operation inspection

4.9 - MOVEMENT SPEED

The movement speed of the following elements is regulated by the movement speed selector switch :

- Jib lifting/rotation.
- Platform rotation/compensation.

The movement speed depends on the user's choices and the environment.

N.B.-:JOYSTICK PROPORTIONALITY MUST BE USED TO ADJUST THE SPEED OF THE OTHER MOVEMENTS.

4.10 - ON-BOARD ELECTRONICS

The machine is equipped with a specific calculator configured for this machine's functionalities. Do not interchange the Calculator (calibration restoration) between machines..

4.11 - RADIUS LIMITATION

N.B.-:THE PRESENCE OF THIS DEVICE DEPENDS ON THE MACHINE CONFIGURATION.

The radius limit indicator flashes to indicate that a controlled movement has occurred to maintain the machine within the stability limit.

Movement is slowed down.

Driving and other additional movements are forbidden.

The radius limit indicator is ON constantly if the operator requests a movement that causes the machine to exceed the radius limit.

4.12 - AXLE EXTENSION

Axle extension improves machine stability.

If the axles are retracted, the machine's capacities are reduced.

Only the following movements are possible :

- Turntable rotation if the boom is in horizontal position.
- Boom raising if the turntable is aligned with the axis.



For HA32RTJ PRO - HA100RTJ PRO :

Risk of overturning : On a slope exceeding 25%, it is forbidden to perform turret orientation movements.



For HA41RTJ PRO - HA130RTJ PRO :

Risk of overturning : On a slope exceeding 19%, it is forbidden to perform turret orientation movements.

If the axles are extended, all movements are possible.

Axle extension is possible if the machine is completely stowed, the jib below horizontal position and the turntable aligned with the axis.

C - Pre-operation inspection

4.13 - DRIVE BUZZER

For EAC standard only :

Each travel or lifting movement activates a buzzer.

4.14 - BOOM CONTROL SYSTEM

For HA41RTJ PRO - HA130RTJ PRO only

Machine stowed, extend the telescope from the platform control box.

Telescope extension must stop as soon as the 1 red stop on the right side of the telescope is visible.

If telescope extension continues once the 1 red stop is visible, stop telescope extension immediately.

Contact HAULOTTE Services® to repair the system.



**Place barriers around the perimeter of the work area.
Never use a faulty machine**



A

B

C

D

E

F

G

H

I

C - Pre-operation inspection



Notes

D - Operation instructions

1 - Operation

1.1 - INTRODUCTION

Only trained and authorized personnel shall be permitted to operate this aerial work platform. ➤

Prior to operation :

- Read, understand and obey all instructions and safety precautions in this manual and attached to the aerial work platform.
- Read, understand and obey all local regulations.
- Become familiar with the proper use of all controls and emergency systems.

1.2 - OPERATION FROM THE GROUND CONTROL BOX

- Turning "ON" and "OFF" of the machine is performed with selector key switch (18).
- Activation of a desired control box is achieved by turning the control box energizing selector switch (229) to the desired position.
- The ground control box is energized and is active ONLY when :
 - The emergency stop on the ground control box is not pushed in (Deactivated).
 - The machine is switched on.
 - Ground control box is selected.
- An E-Stop button at each control box stops all movements when pressed in; including shutting off an engine (if equipped).

N.B.-:-AN E-STOP BUTTON PRESSED IN DOES NOT TURN OFF THE MAIN POWER SUPPLY TO THE MACHINE.

- An Enable Switch (228) provided must be activated and maintained to authorize one or more function movements. If Enable Switch (228) is kept engaged without selecting a function movement for more than 8 s; Enable Switch is automatically de-activated.
- The release of "Enable switch" (228) while performing a movement stops all the movements. The stop of movements is progressive. If the Enable Switch system is re-pressed, the movement doesn't restart. It could restart only when the selected function switch/joystick is released to neutral position.
- All switches and joystick operating a movement, return automatically to neutral when released.
- At power up, a switch in it's neutral position will be taken into account to authorize movement.
- Enable Switch / Emergency pump
 - Engine running, the switch acts as an Enable Switch only.
 - Engine stopped, the switch acts as the Enable switch and operate the emergency pump control.

D - Operation instructions

- Overriding system : The ground control box is designed for maintenance and emergency rescue operations only. Refer to  Section D 4.2 To rescue operator in platform.
- The status of the switches is tested automatically when the machine is switched on, and checked at every starting. A switch will be active only after it has been detected to be in neutral position. The following switches are not controlled :
 - Accelerator: engine rpm
 - Beacon light (if fitted)
- A switch provides the start and stop of the engine.
- Engine speed (If fitted) : This switch increases the engine rpm to the maximum speed.
- A buzzer beeps in the following conditions :
 - When power is switched on.
 - Overload (if fitted).
 - Slope if machine is out of stowed position.
 - Hydraulic oil overheating.
 - Movements option.
 - Driving option.
 - Movement option and driving.
- Indicators / Cluster : All indicators are checked after powering on the machine.

1.3 - OPERATION FROM THE PLATFORM CONTROL BOX

- The platform control box is energized only when :
 - The E-stop buttons on both ground and platform control boxes are not pressed in.
 - Machine switched on at ground control box.
 - Platform control box selected from ground control box.
 - Overriding system not activated.
- A faulty joystick is not taken into account to control a movement. If this fault disappears, the movement is authorised again.
- An E-stop button is present at each control box, it stops all movement and the engine (if equipped). The E-stop button doesn't have function to turn off the power supply of the machine.
- An Enable /Foot Switch (228) (foot switch in the basket) is present and should be activated to authorize one or more function movements. If the Enable Switch is kept active for more than 8 seconds without selecting a function movement, then movement is disallowed. The enable switch must be released (reset) before movement can occur.

D - Operation instructions

- The release of "Enable switch" (228) while performing a movement stops all the movements. The stop of movements is progressive. The function movements can only be selected when the corresponding function switch is returned to neutral position.
- All switches and joystick operating a movement, return automatically to neutral when released.
- At power up, a switch in it's neutral position will be taken into account to authorize movement.
- The status of the switches and joysticks is checked when the machine is switched on. A switch or joystick is only considered validated after it is detected in neutral.
- A buzzer beeps in the following conditions :
 - When power is switched on.
 - Overload (if fitted).
 - Slope if boom is out of the stowed position.
- Emergency pump : See dedicated paragraph
- Indicators - All the indicators are tested
 - When the machine is switched on.
 - When the combustion engine is started from the platform control box.



















- **While driving, always place the boom above the rear axle, in the direction of movement.**



While driving on a slope :

- **Always orientate the machine in the direction of the slope.**
- **Always place the boom and the arms in fully retracted and in stowed position.**
- **Do not travel down slopes in high speed.**
- **Do not drive fast in narrow or cluttered areas. Keep speed under control while making turns or sharp bends.**

D - Operation instructions

Symbol	Description
	Machine switched on : <ul style="list-style-type: none"> • Rapid flashing : When the platform control box has not been selected or the upper or ground emergency stop is pressed (machine switched on but control box inactive) • Constantly on : When the machine is switched on
	Foot Switch : <ul style="list-style-type: none"> • Constantly on : Foot Switch activated and validated
	Faults : <ul style="list-style-type: none"> • Rapid flashing : If a fault is active (current fault)
	Overload (If machine equipped with weighing system) : <ul style="list-style-type: none"> • Rapid flashing : Faulty weighing / overload system • Illuminated in case of overload
	Tilt sensor (if fitted) : <ul style="list-style-type: none"> • Permanently on in case of tilting, machine folded or unfolded
	Radius limitation <ul style="list-style-type: none"> • Flashing : Calibration fault or automatic reach limitation • Permanently lighted : Movement disabled by the reach limitation system
	<ul style="list-style-type: none"> • Constantly on : Valid load selection • Flashing : If the machine leaves the 450 kg zone with the selector on 450 kg¹
	<ul style="list-style-type: none"> • Constantly on : Valid load selection • Flashing : If the load selection is changed to 450 kg in the 230 kg zone²
	Platform leveling +/- 10° : <ul style="list-style-type: none"> • Illuminated if the angle of the platform reaches +/- 10° in relation to the horizontal and movement control
	Low fuel level
	Combustion engine pre-heating : <ul style="list-style-type: none"> • Illuminated while engine is pre-heating • Off if engine started and if post-heating
	Engine warning : <ul style="list-style-type: none"> • Lighted in case of minor engine fault (e.g. water in the diesel, clogged air filter, etc.) • Lighted or flashing in case of fault managed by the engine ECU
	Engine shutdown : <ul style="list-style-type: none"> • Lighted in case of major engine fault (e.g. engine overheating, oil pressure, alternator fault, etc.) • Lighted in case of faults managed by the engine ECU
	DPF regeneration required : <ul style="list-style-type: none"> • Permanently lighted if the particle filter requires regeneration with a high clogging level³
	DPF regeneration in progress, high temperature in the exhaust system (HEST)⁴
	DPF regeneration inhibited⁵

1. If machine equipped with dual load
2. If machine equipped with dual load
3. If engine equipped with Particulate Filter Regeneration
4. If engine equipped with Particulate Filter Regeneration
5. If engine equipped with Particulate Filter Regeneration

D - Operation instructions

2 - Ground control box

2.1 - TO START AND STOP THE MACHINE

- At the ground control box, check that the E-stop button (15) is not pressed.
- Turn ON / OFF key switch (18) to the right to turn ON. The LED display panel comes on.
- Turn the control box selector (229) to the right to select ground control box.
- Push the starter selector (228) upwards. During pre-heating, the indicator (LED 5) comes on, preheating is carried out. The engine starts. The indicators go out.
- Let the engine heat up.

N.B.-:THE DURATION OF PREHEATING DEPENDS ON THE TEMPERATURE OF THE ENGINE.

To shut-down the machine from the ground control box :

- Push the starter selector (228) upwards. The engine stops.
- Turn the key switch (18) to the OFF position.
- The machine is now switched off. .

N.B.-:THIS OPERATION TURNS THE MACHINE OFF AND IT IS REQUIRED TO PREVENT BATTERY DISCHARGE.

2.2 - MOVEMENT CONTROL



Platform leveling is available, regardless of the work height. Even at low movement speeds, use the controls with caution.

N.B.-:RELEASING THE ENABLE SWITCH (FOOTPEDAL) WILL STOP ALL MOVEMENTS.

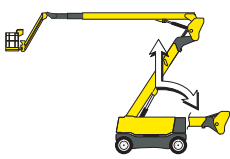
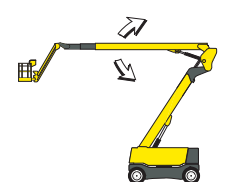
Ground box controls (emergency station)

Command		Action
Raising / lowering of arm		Push the arm raise / lower selector (47) upwards to raise the arm.
		Push the arm lift/lower selector (47) downwards to lower the arm.
Raising / lowering of boom		Push the boom raising switch (10) upwards to raise the boom.
		Push the boom raising switch (10) downwards to lower the boom.

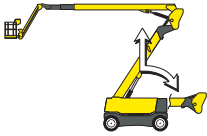
D - Operation instructions

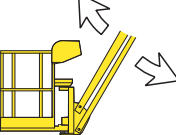
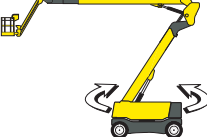
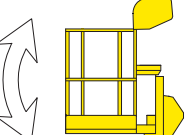
Command		Action
Arm telescope extension/retraction		<p>Push the arm telescoping selector (47) upwards to extend the telescope.</p> <hr/> <p>Push the arm telescoping selector (47) downwards to retract the telescope.</p>
Boom telescoping extend / retract		<p>Push the boom telescoping switch (9) to the left to extend the boom.</p> <hr/> <p>Push the boom telescoping switch (9) to the right to retract the boom.</p>
Jib raising / lowering		<p>Push the jib switch (8) upwards to raise the jib.</p> <hr/> <p>Push the jib switch (8) downwards to lower the jib.</p>
Turntable rotation		<p>Push the turntable rotation selector switch (14) to the left for a clockwise (CW) rotation.</p> <hr/> <p>Push the turntable rotation switch (14) to the right for a counter clockwise (CCW) rotation.</p>
Platform leveling		<p>Move the platform leveling switch (13) to the right to raise the platform.</p> <hr/> <p>Move the platform leveling switch (13) to the left to lower the platform.</p>

2.3 - ADDITIONAL CONTROLS FROM THE GROUND CONTROL BOX

For the machines equipped with beacon light :

- Push the beacon light selector switch (24) to the right to turn ON the beacon light.
- Push the beacon light selector switch (24) to the left to turn OFF the beacon light.

D - Operation instructions

3 - Platform control box

3.1 - TO START AND STOP THE MACHINE

To start the machine :

At the ground control box :

- Check that the E-stop button (15) is not pressed in.
- Turn ON/OFF key switch (18) to the right to turn ON.
- LED (101) at platform display lights up.
- Turn the control box energizing selector switch (229) to the left to energize platform box.

At the platform control box :

- Check that the E-stop button (46) is not pressed in.
- Push the starter selector switch (230) upwards. During pre-heating LED (102) at platform display panel and LED (5) at ground display panel will light up. Pre-heating begins and the engine starts.
- Allow the engine to heat up and initialize.

To stop the engine :





- Push engine start switch (230) upwards.

3.2 - DRIVE AND STEER CONTROL

To operate driving and steering functions, simultaneously operate the drive joystick (33) and the Foot Switch.

Before driving, locate the green / red orientation arrows on the chassis and platform control box. Move the drive controls in a direction matching the directional arrows.

N.B.-:ON UNEVEN TERRAIN, LOWER THE BOOM TO IMPROVE THE DRIVE PERFORMANCE.

Command		Action
Steering		Press thumb/rocker switch on joystick (33) to the right to steer right.
		Press thumb/rocker switch on joystick (33) to the left to steer left.
Drive speed		Position the drive speed selector switch (45) on  for high-speed driving.
		Position the driving speed selector (45) on  for low-speed driving (short distance, final approach, unloading from lorries/trucks).

D - Operation instructions

3.3 - MOVEMENT CONTROL



Activate the desired control and the enable switch (Foot Switch) simultaneously to perform that selected function.

Foot Switch

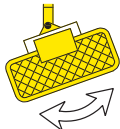
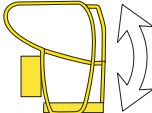
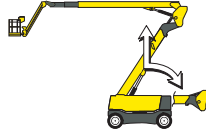

Command		Action
Raising / lowering of arm		Push the boom or arm position selector (36) downwards. Push the arm lift/lower joystick (28) forwards to raise the arm. Push the arm lift/lower joystick (28) backwards to lower the arm.
Raising / lowering of boom		Push the boom or arm position selector (36) upwards. Push the boom raising joystick (49) forwards to raise the boom. Push the boom raising joystick (49) backwards to lower the boom.
Jib raising / lowering		Push the jib switch (37) upwards to raise the jib. Push the jib switch (37) downwards to lower the jib.
Turntable rotation		Push the turntable rotation switch (49) to the left for an clockwise rotation. Push the turntable rotation switch (49) to the right for an anti-clockwise rotation.

D - Operation instructions

Command		Action
Platform rotation		Move the platform rotation selector (38) to the right for a counter clockwise (CCW) rotation.
		Move the platform rotation selector (38) to the left for a clockwise (CW) rotation.
Platform leveling		Push the platform levelling switch (40) forwards to lift the platform.
		Push the platform levelling switch (40) backwards to lower the platform.
Arm telescope extension/retraction		Push the boom or arm position selector (36) downwards.
		Push the arm telescoping joystick (28) forwards to extend the telescope.
Boom telescoping extend / retract		Push the boom or arm position selector (36) upwards.
		Push the boom telescope joystick (28) forwards to extend the telescope.
		Push the boom telescope joystick (28) backwards to retract the telescope

3.4 - ADDITIONAL CONTROLS

- Horn : Push the horn selector (43) to the right to sound the horn. The horn stops when the selector switch is released.
- Differential lock : Press the differential blocking touch pads (35).

D - Operation instructions





4 - Axle extension control box

4.1 - PREPARE THE MACHINE



Prepare the machine before any axle extension or retraction operation.

1. Locate the 3 control boxes on the machine as illustrated below :

	Platform control box	
	Ground control box	
	Axle extension control box (Back of the machine)	

Check that the emergency stop button on each has been deactivated.	
--	---

D - Operation instructions

- Go to the ground control box and start the machine.

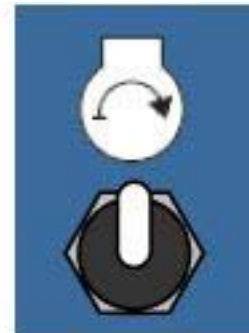

- Raise the jib approximately 1m (3 ft 3 in).



- Set the control box energizer selector switch (229) to the center position to activate the axle control box.



N.B.-:THE PLATFORM AND GROUND BOXES CONTROLS ARE DE-ACTIVATED IN THIS POSITION.

- Go to the back of the machine to access axle extension control box.

D - Operation instructions

4.2 - AXLE EXTENSION OPERATION

4.2.1 - For rear axle extension

Use E1 and E2 levers (Refer to figure a).



- If the two outrigger cylinders are extended, the axle extension controls are de-activated.
- Always extend the axles before using the machine.

1. Lower lever (E1).
 - The outrigger cylinder is lowered (extended).
 - The chassis is lifted.
 - The wheels no longer touch the ground.
2. Keeping lever (E1) lowered and lowering lever (E2) will extend the rear axle.



While the axle is being extended, the buzzer sounds and driving is deactivated. The buzzer stops when the axle is totally extended and the outrigger cylinder is completely raised (retracted).

Once the rear axle is fully extended :

3. 1 to 2 s after the buzzer stops, release lever (E2).
4. Lift lever (E1).
 - The outrigger cylinder is raised (retracted).
 - The chassis is lowered.
 - The wheels touch the ground.



If the buzzer sounds during the movement, the axles are either not fully extended or not fully retracted.

Figure a

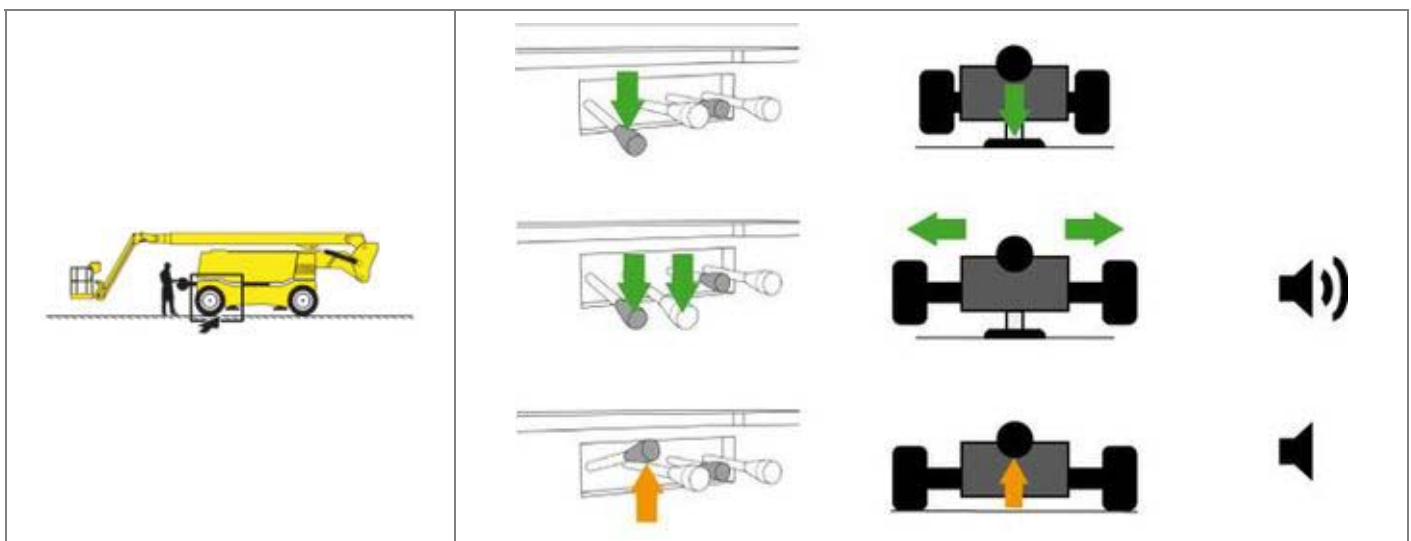

D - Operation instructions

4.2.2 - For front axle extension

Use E3 and E4 levers (Refer to figure b).



- If the two outrigger cylinders are extended, the axle extension controls are de-activated.
- Always extend the axles before using the machine.

1. Lower lever (E3).

- The outrigger cylinder is lowered (extended).
- The chassis is lifted.
- The wheels no longer touch the ground.

2. Keeping lever (E3) lowered and lowering lever (E4) will extend the rear axle.



While the axle is being extended, the buzzer sounds and driving is deactivated. The buzzer stops when the axle is totally extended and the outrigger cylinder is completely raised (retracted).

Once the rear axle is fully extended :

3. 1 to 2 s after the buzzer stops, release lever (E4).

4. Lift lever (E3).

- The outrigger cylinder is raised (retracted).
- The chassis is lowered.
- The wheels touch the ground.



If the buzzer sounds during the movement, the axles are either not fully extended or not fully retracted.

Figure b

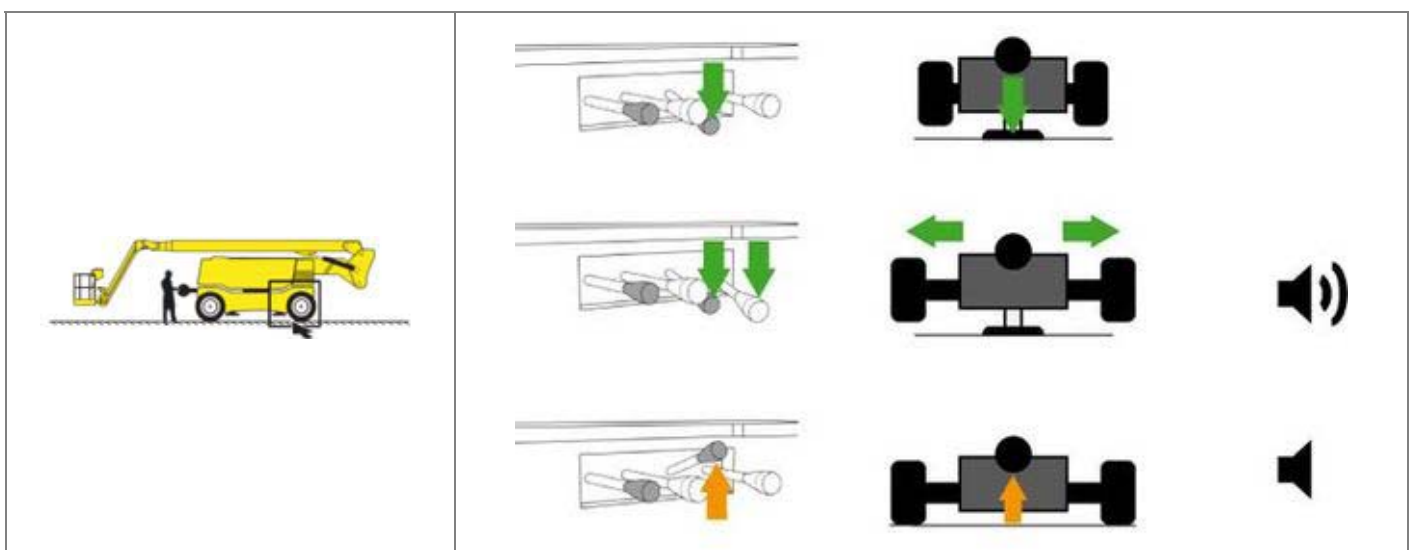

D - Operation instructions

4.3 - AXLE RETRACTION OPERATION

4.3.1 - For front axle retraction

Use E3 and E4 levers (Refer to figure c).



If the two outrigger cylinders are extended, the axle retraction controls are de-activated.

1. Lower lever (E3).
 - The outrigger cylinder is lowered (extended).
 - The chassis is lifted.
 - The wheels no longer touch the ground.
2. Keep lever (E3) lowered and lift lever (E4) to retract the front axle.



While the axle is being retracted, the buzzer sounds and driving is deactivated. The buzzer stops when the axle is totally retracted and the outrigger cylinder is completely lowered (extended).

Once the front axle is totally retracted :

3. 1 to 2 s after the buzzer stops, release lever (E4).
4. Lift lever (E3).
 - The cylinder is raised (retracted).
 - The chassis is lowered.
 - The wheels touch the ground.



If the buzzer sounds during the movement, the axles are either not fully extended or not fully retracted.

Figure c

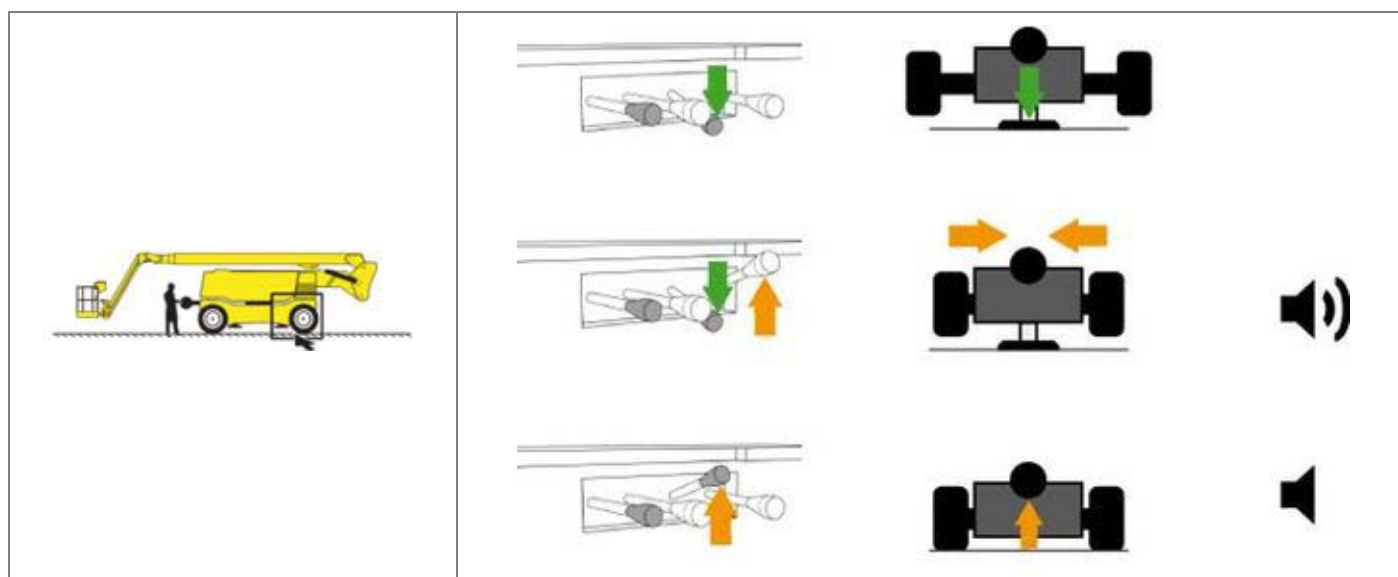

D - Operation instructions

4.3.2 - For rear axle retraction

Use E1 and E2 levers (Refer to figure d).



If the two outrigger cylinders are extended, the axle retraction controls are de-activated.

1. Lower lever (E1).
 - The outrigger cylinder is lowered (extended).
 - The chassis is lifted.
 - The wheels no longer touch the ground.
2. Keep lever (E1) lowered and lift lever (E2) to retract the front axle.



While the axle is being retracted, the buzzer sounds and driving is deactivated. The buzzer stops when the axle is totally retracted and the outrigger cylinder is completely lowered (extended).

Once the front axle is totally retracted :

3. 1 to 2 s after the buzzer stops, release lever (E2).
4. Lift lever (E1).
 - The cylinder is raised (retracted).
 - The chassis is lowered.
 - The wheels touch the ground.



If the buzzer sounds during the movement, the axles are either not fully extended or not fully retracted.

Figure d

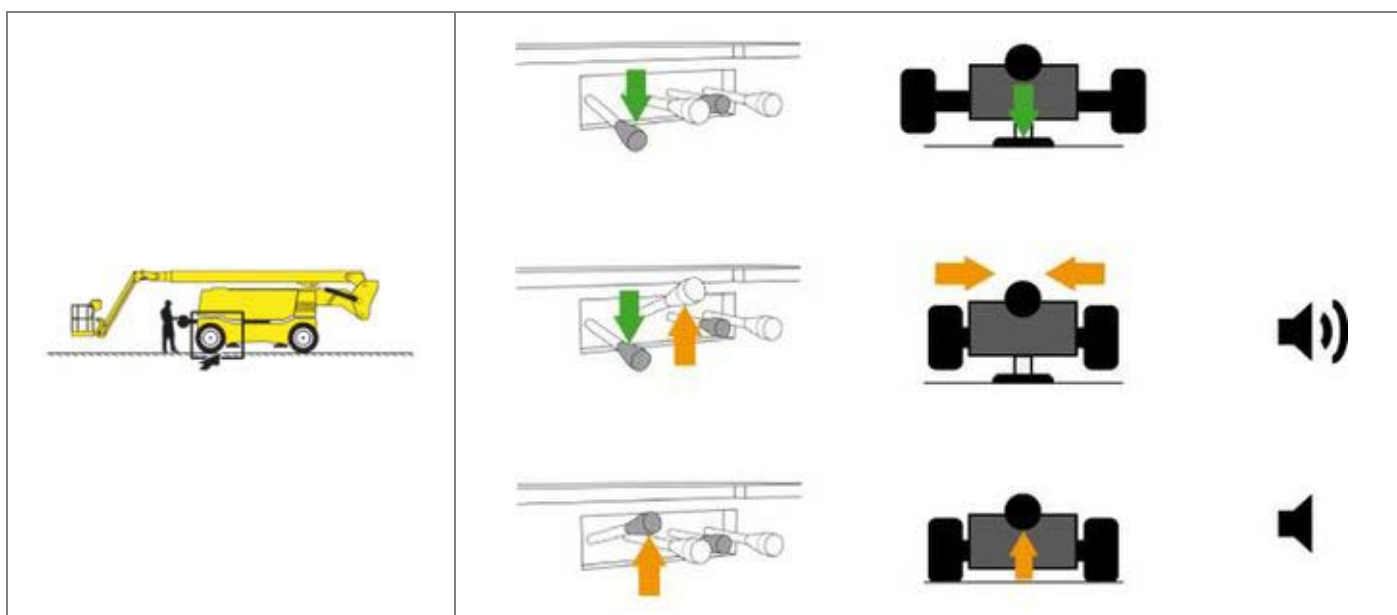

D - Operation instructions

5 - Link piece position check



Ensure that nothing is in the way before starting any manoeuvres.

Link piece position check

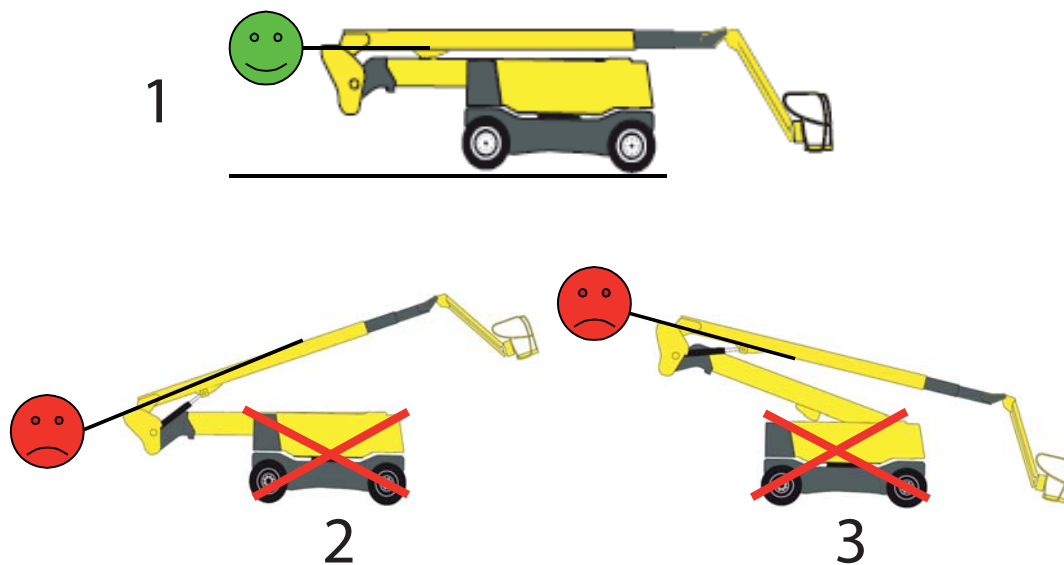

Marking	Description
1	If the link piece is not in the correct position, the machine must not be used until this has been corrected
2	Link piece to the front
3	Link piece to the rear

The link piece position reset is automatic when the arm reaches the end of its descent.



After each work shift, ensure that the arm is fully lowered and rests on the turntable.

To check that the link piece is positioned correctly, the arm must be at the lowest stop point and the machine on level ground. The upper edge of the link piece must then be horizontal.

The decal (R38) placed on the link piece is a second source used in checks.



If it is impossible to reposition the link piece, DO NOT use the machine and call the HAULOTTE Services® After Sales Service

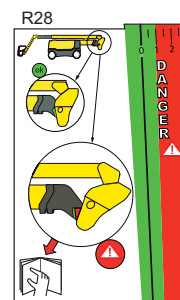

D - Operation instructions

6 - Radius limitation

For HA41RTJ PRO - HA130RTJ PRO only

6.1 - PRINCIPLE

When the machine is at the radius limit before driving is disabled, the (LED 113) indicator comes on. The telescope must be retracted to re-activate driving. If the rear radius limit is reached, the boom must be lowered slightly to re-activate driving.

6.2 - PROCEDURE

6.2.1 - Front radius limitation

Boom extension is limited in zone A1 as long as the second arm telescope has not started to extend (boom length is limited to 14,2 m (46 ft 7 in) maximum, i.e. 2,40 m (7 ft 10 in) of the telescope). Boom movement is automatically stopped (the radius limit indicator is fixed).

As soon as the second telescope is partially extended, boom telescope extension is limited in zone (boom length is limited to 16,1 m (52 ft 10 in) maximum, i.e. 3,37 m (11 ft 1 in) of the telescope). Boom movement is automatically stopped (the radius limit indicator is fixed).

When the arm telescope is fully extended, the boom telescope extension is limited in zone ( Section G 3-Working area / Range of motion). Boom movement is automatically stopped (the radius limit indicator is fixed). In zone A3, when a boom lowering movement control is activated, the system automatically retracts the boom telescope to keep the user within the stable zone.

When an arm lowering control is activated from the platform control box, the boom telescope is automatically retracted to keep the user within the stable zone (the radius limit indicator flashes). The operator must retract the boom telescope to re-activate the arm lowering function.

6.2.2 - Rear radius limit

Boom raised : Lifting is automatically stopped when the radius limit is reached (the radius limit indicator is fixed).

D - Operation instructions

7 - Rescue and emergency procedures

7.1 - IN CASE OF POWER LOSS

In case of loss of the main power source, the secondary (back-up) power unit, powered by the starting battery, allows movements to be controlled from both the ground and platform control boxes.

As the electric pump has limited power, it is advisable to reach the ground in the most direct manner possible.

The use of the electric pump is exclusively reserved for lowering the boom in emergency situations only. You are advised to retract the telescope before lowering the boom.

N.B.-:TEST THE OPERATION OF EMERGENCY SYSTEM ATLEAST ONCE A MONTH. REFER TO THE SERVICE MANUAL

Depending on the control box in use, push and hold the back-up/auxiliary power switch (228) at ground box or switch (41) at platform box. Retract the boom and lower it by using switches (9) and (10) at ground box or switch (28) and joystick (49) at platform box.

In an emergency, if the operator has to exit the platform while it is elevated, the transfer of the operator must respect the following recommendations. :

- Exit onto a sturdy and safe structure.
- Allowance must be made for the possibility of boom deflection when egressing from the platform.
- The occupant(s) must ensure that 2 lanyards are used for security/safety. One must be attached to the designated anchorage point on platform the occupant(s) is in and the other attached to the structure intended to get on.
- Do not leave platform without taking into account the allowance for possibility of boom deflection when exiting platform.
- Occupant(s) must exit the current platform through the normal access.

N.B.-:-DO NOT DETACH THE LANYARD FROM THE CURRENT PLATFORM IF THE TRANSFER TO THE NEW STRUCTURE POSES ANY DANGER OR UNTIL THE TRANSFER IS SAFELY COMPLETED. DO NOT ATTEMPT TO CLIMB DOWN THE BOOM. INSTEAD WAIT FOR ASSISTANCE FOR A SAFE EXIT.

D - Operation instructions

7.2 - TO RESCUE OPERATOR IN PLATFORM

In a situation where an operator located in the platform needs to be rescued (for example in case of illness, injury or trapped against a structure making the control box inaccessible), the rescue personnel at ground level needs to obtain rapid and direct access to operating functions.

HAULOTTE® has implemented a control system for safely lowering the operator to the ground in the event of an emergency to enable him to receive the necessary treatment.

Unlike the ground control box used in lowering the boom, the overriding system allows trapped occupant(s) be lowered to the ground level, even if an E-Stop is engaged or if an overload is detected.

In this situation, supervisor(s) at ground level must turn the control box selector (229) to the "right" on the ground control box to take control. To safely activate movements from the ground control box, the Enable Switch (228) must be held activated/depressed.

Procedure :

- Turn the control box selector (229) to the "right" to energize the ground control box.
- The platform box controls are now de-energized.
- Check that the E-Stop button (15) at ground is not pressed in.
- To lower the platform, hold Enable Switch (228) downwards and simultaneously push the desired function switch.
- If the E-stop button (15) or a safety device do not allow normal movement from the ground control box, the overriding system is operated as follows :
 - Operate the "overriding system" switch (245) on the ground control box.
 - Simultaneously, push upwards and maintain overriding switch (245) in addition to desired movements actuator to obtain movement of the extending structure.

N.B.-:OPERATION OF THE "OVERRIDING SYSTEM" SWITCH MUST BE AN EXCEPTION AND NOT A NORMAL EMERGENCY OPERATION.

D - Operation instructions

7.2.1 - Operation of overriding system from ground control box

ONLY in these conditions, activate the "overriding system" switch (245) located under the cover and simultaneously press the platform lowering button until the safety mechanisms are deactivated (alarms stop) and therefore normal movements are possible again, or until the operator can be rescued.

"Overriding system" switch under cover



Once rescue operations are complete, write an incident report.

7.3 - NO POWER AVAILABLE

In case of loss of the main power and the secondary power unit not functioning, do not attempt to activate any function movement using hydraulic manifold unless trained and authorized by HAULOTTE Services®. All safety functions are no longer active and several hazards may occur. Improper use of the equipment will result in death or serious injuries.



If the operator cannot be lowered by any of the above mentioned methods, contact HAULOTTE Services® immediately.

D - Operation instructions

8 - Transportation

8.1 - PUTTING IN TRANSPORT POSITION

During loading, ensure that :

- The loading ramp can support the machine weight.
- The loading ramp is correctly attached to transport vehicle.
- The loading ramp has sufficient grip surface.
- The transport vehicle must be parked on a level surface and must be secured to prevent rolling away while machine is being loaded or unloaded.

Do not place yourself below or too close to the machine during loading.

The machine must be completely in the stowed configuration :

- Check the platform is completely empty.

To climb the slope, select low driving speed.

If the slope is too steep, use a winch in addition to the low speed drive.

- Lower the boom.
- Ensure that the jib is raised as necessary to give ground clearance when driving the machine onto the loading ramp.
- Drive onto the truck bed slowly.



The machine must be loaded with the platform facing the truck cab.

- Secure the machine to the tie down points provided (Section D-Machine layout).
- Lock the turntable with the rotation stop pin located under the turntable before transporting (Section D-Machine layout).
- The platform/basket must be chocked and the boom strapped to prevent bouncing up and down, thus preventing possible material damage during transporting.
- Do not use excessive downward force when securing boom section.



A wrong move can lead to machine tipping over and may cause serious injuries and material damage.



Always align the boom in the axis of the machine and climb slopes with the platform lowered and on the downhill side of the machine.



To enter or exit from the platform : Falling Hazards ( Section A 2.1.2).

D - Operation instructions

Loading recommendation of a HA41RTJ PRO for transport in accordance with the regulations



D - Operation instructions

8.2 - MACHINE LAYOUT — HA32RTJ PRO - HA100RTJ PRO - HA41RTJ PRO - HA130RTJ PRO

HA32RTJ PRO - HA100RTJ PRO

Turntable rotation enabled



Turntable rotation disabled



A

B

C

D

E

F

G

H

I

D - Operation instructions

HA41RTJ PRO - HA130RTJ PRO

Turntable rotation enabled



Turntable rotation disabled



D - Operation instructions

Machine stowing

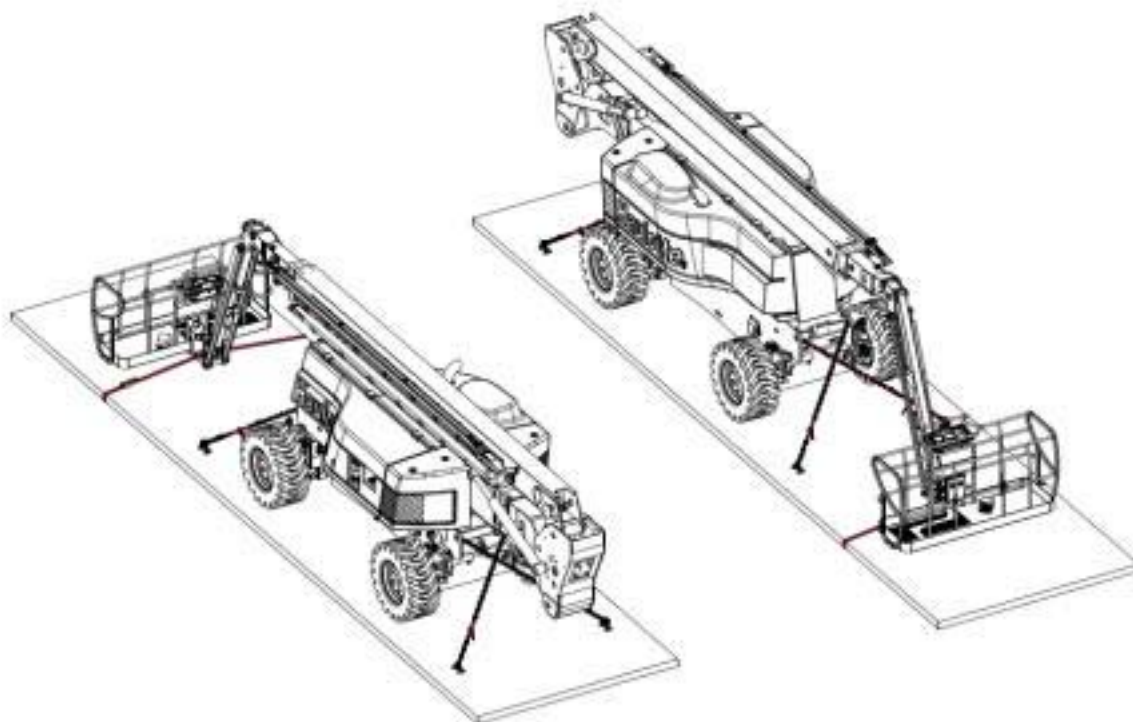

N.B.:-SECURE TURNABLE WITH THE TURNABLE LOCKING PIN BEFORE TRAVELING LONG DISTANCES OR HAULING MACHINE ON A TRUCK.

8.3 - UNLOADING

Before unloading, check that the machine is in good condition.

- Remove the turntable rotation locking pin (Section D-Machine layout).
- Remove the tie downs.
- Select low drive speed at the platform control box.
- Start the machine from platform control box.



Warning : Upon starting a machine that has been secured and transported, the safety system may detect a false overload preventing all movement from the platform control box.

To reinstate the system, lift the jib a few centimetres (inches) using the ground control box.

D - Operation instructions

8.4 - TOWING



In the event of a machine breakdown, the machine can be towed a short distance to load it onto a transport vehicle :

- Ensure that no one is in the platform during towing.
- Ensure boom is in the stowed position and the turntable is locked, prior to towing.
- The platform must be empty.

To tow a broken-down machine, disconnect the wheel drive hubs.

Perform this operation on flat ground with wheels chocked.

In the towing configuration, the machine braking system is inactive. Use of a drawbar is recommended :

- Do not exceed the maximum freewheel speed (Refer to  Section B 4.1 - Technical specifications).
- Do not exceed a grade of 25%.

8.4.1 - Disengaging the drive hubs

1. Loosen and remove the 2 fastening screws (1).
2. Remove the clutch stop (2).
3. Turn the clutch stop so that its domed part is towards the interior of the wheel gears.
4. Attach the clutch stop.

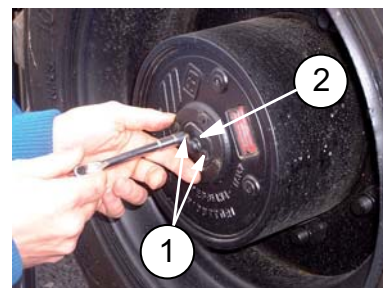

When drive hubs are disengaged, the machine is in free wheel mode and the brake system no longer functions.

8.4.2 - Re-engaging the drive hubs

After repairing the machine, re-engage the wheel drive hubs.

1. Loosen and remove the 2 fastening screws (1).
2. Remove the clutch stop (2).
3. Turn the clutch stop so that its domed part is towards the exterior of the wheel gears.
4. Attach the clutch stop.
5. Check the wheel gear oil level.

D - Operation instructions

8.5 - STORAGE



The machine can be stored in a designated area when not in use. If it has been stored for longer than 3 months without use then a periodic inspection must be conducted.



For engine storage condition follow engine supplier operator and maintenance manuals.

Machine must be parked in a protected/designated area with the boom in a stowed configuration, however the boom can be raised but must not be extended. Make sure there is no load in the platform.

It is recommended that the machine is not stored or immobilized unfolded.

Ensure all access panels, doors and side compartment covers are shut and secured.

Turn the energizing key selector switch (18) at the ground control box to the "left" to shut OFF the power.

Ensure that the turntable rotation locking pin is removed and stored properly.

Remove the ignition key to prevent unauthorized operation of the machine.



Storing of the machine with an obstacle under the boom structure is forbidden.



To avoid any risk of corrosion on rods of cylinders during a storage period of more than 1 month :

- In a normal atmospheric environment : perform a complete cycle for the cylinders every 2 months while they are in storage.
- In harsh environments (high levels of salinity in the atmosphere: close to the sea, industrial environment with chloride emissions and/or humidity >70%), we recommend applying the following protection process :
 - Wash and rinse the entire machine with plenty of clean water.
 - Dry all the cylinder rods using an air gun.
 - Apply a solvent-based oil leaving an oily film after evaporation of the solvent directly to all rods left exposed when the machine is in storage position.
 - Re-apply the product every month.



After washing the machine, make sure it is fully air-dry and does not contain moisture on corrosive parts (cylinders rods for example).

Do not wash any electrical components, particularly with high pressure washer. Wipe away dirt from around electrical components with a dry cloth.

D - Operation instructions

8.6 - LIFTING OPERATION

Before any crane operation, it is necessary to take into account the following points :



ONLY trained and authorized personnel should attempt to lift the machine.

Do not operate machine unless you have :

- been fully trained and are qualified in proper operation.
- read and understood the information in the Operator's manual of the machine.

8.6.1 - Safety precautions

It is the responsibility of the Operator to ensure there are no personnel or obstructions to safely perform the operation. :

- Engine exhaust contain some chemicals that are harmful. Always run an engine in a well-ventilated area.
- If machine is operated inside a closed building, ensure that exhaust is properly routed to the outside of the structure.

8.6.2 - Necessary equipment



- PPE (Personal Protective Equipment: glove, safety shoes, glasses, etc ...)
- Standard tool kit
- 2 spreaders 3 m (13 ft 1 in) 25 T
- 12 shackles 12 T
- 4 slings 4 m (13 ft 1 in) 8 T
- 4 slings or chains 4 m (13 ft 1 in) 12 T
- 2 slings or chains 6 m (19 ft 8 in) 12 T
- for HA32RTJ PRO - HA100RTJ PRO : 2 slings or chains 5,40 m (17 ft 9 in) 12 T
- for HA41RTJ PRO - HA130RTJ PRO : 2 slings or chains 5,20 m (17 ft 1 in) 12 T

Technical specifications

Machine type	Maximum weight
HA32RTJ PRO - HA100RTJ PRO	20100 kg (44321 lb)
HA41RTJ PRO - HA130RTJ PRO	23900 kg (52691 lb)

D - Operation instructions

8.6.3 - Preliminary procedures

- Inspect the surrounding area and position the machine at a safe distance from electrically charged conductors to ensure that no part of the machine is within an unsafe area. Always stay clear of overhead obstructions.
- Respect the local rules and the minimum safe distance from power lines.
- Turn off the engine.
- Remove the ignition key.
- Ensure that the main power is disconnected.
- Place a "DO NOT USE" decal near the start/stop switches to inform personnel that machine is not operational during the lifting process.
- Cordon off the area surrounding the machine to keep personnel, vehicles and moving equipment away from the machine.
- Remove all loose items from the machine.
- Ensure that vehicle capacity and loading equipment - hoists, slings, straps, etc. are of sufficient strength to withstand maximum machine weight.
- Attach the rigging ONLY to the designated lifting points on the machine.

8.6.4 - Procedure for the use of slings

The machine must be completely stowed, with the axles extended and the turntable at 90 ° in relation to the axis of the chassis. Designated lifting points are marked/labeled with the following symbol .

1. Position the spreaders line up with the chassis.
2. Fold up the 4 slings 4 m (13 ft 1 in) 4 T over the axles with protective sheathing positioned appropriately. Adjust properly to prevent any damage to the machine.

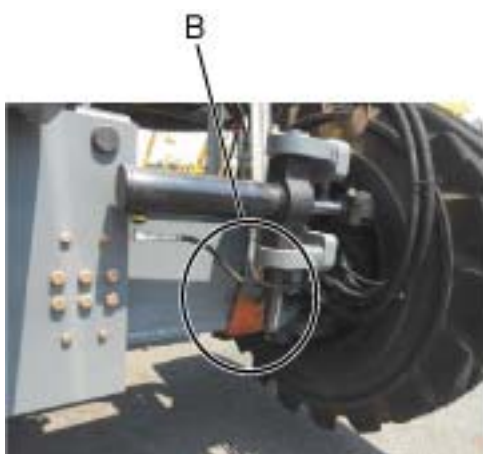

D - Operation instructions



Make sure that the steering rods and associated hoses are not captured by the slings over the axle.

Pay particular attention to avoid slings over sharp edged surfaces as they may be severed/damaged.

3. Attach the slings using shackles



Properly adjust rigging to keep the machine level and to minimize the risk of damage to the machine.



- Lifting procedure must be handled very carefully.
- All movements of the machine must be performed slowly and deliberately to minimize swaying of the machine being lifted.
- Always keep machine as close as possible to the ground level.

D - Operation instructions

HA32RTJ PRO - HA100RTJ PRO

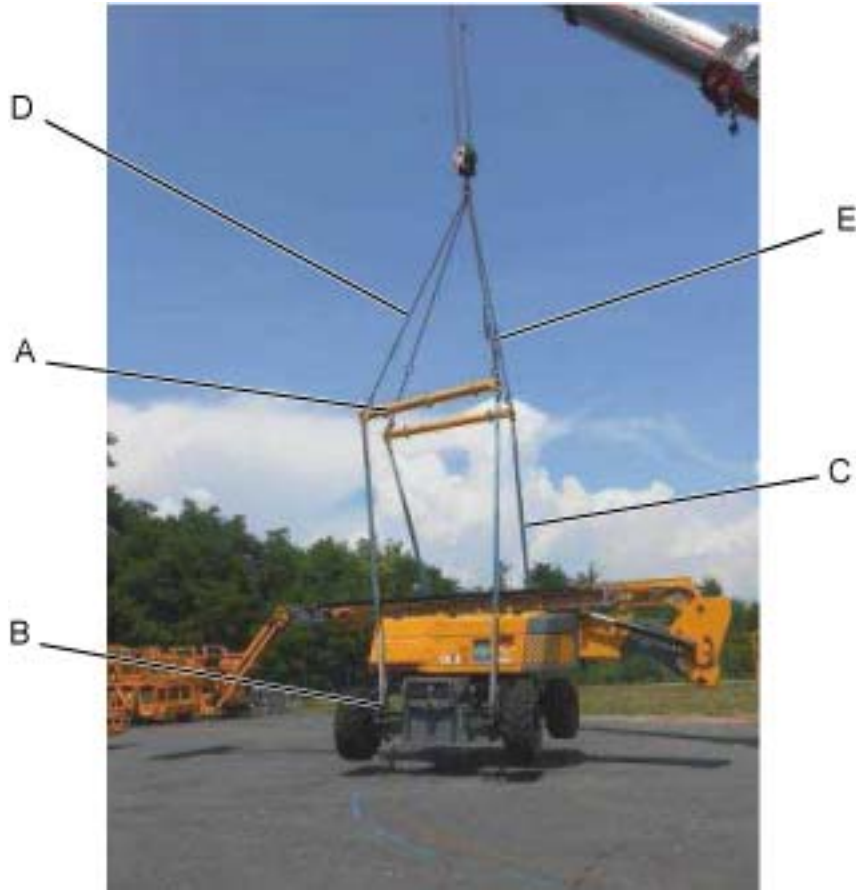

A

➤ B

C

D

E

F

G

H

I

D - Operation instructions

HA41RTJ PRO - HA130RTJ PRO

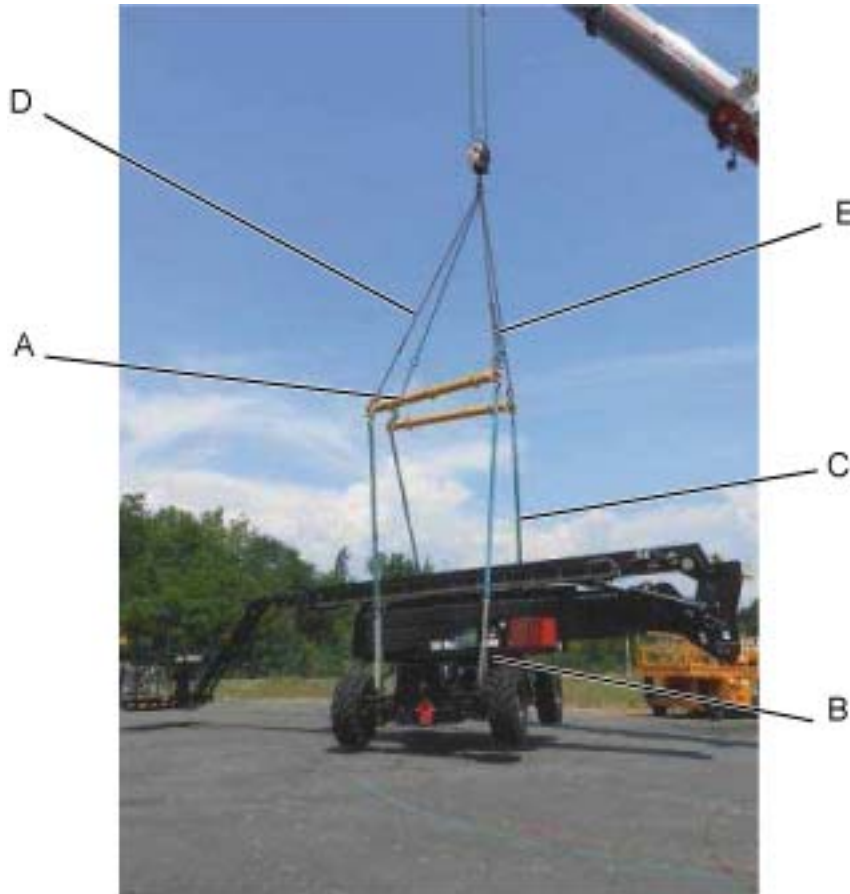

Marking	Description
A	2 spreaders 3 m (9 ft 10 in) 25 T at 90 ° to the axis of the chassis
B	4 slings 4 m (13 ft 1 in) 8 T to attach the machine
C	4 slings 4 m (13 ft 1 in) 12 T and 8 shackles 12 T between the attachment straps and the spreaders
D	2 slings 6 m (19 ft 8 in) 12 T and 2 shackles 12 T between the attachment straps and the spreaders
E	for HA32RTJ PRO - HA100RTJ PRO : 2 slings or chains 5,40 m (17 ft 9 in) 12 T for HA41RTJ PRO - HA130RTJ PRO : 2 slings or chains 5,20 m (17 ft 1 in) 12 T

D - Operation instructions

9 - Cold Weather Recommendations

In cold weather conditions, allow engine to run for at least 5 min to warm up ; before operating any function thereby preventing any damage to the hydraulic system.

In extreme cold conditions, machines should be equipped with optional cold start kits.

Attempting to start engine when temperature is in the negative range, may require the use of a booster battery.

If engine fails to start, do not crank for an extended time. Allow starter to "cool off" for a few minutes before attempting again. If engine fails after several attempts, refer to the engine maintenance manual.

N.B.-:INITIAL STARTING SHOULD ALWAYS BE PERFORMED FROM THE GROUND CONTROL BOX.

9.1 - ENGINE OIL

The correct SAE viscosity grade of oil is determined by the minimum ambient temperature during cold engine start-up, and the maximum ambient temperature during engine operation.

Generally, use the highest viscosity oil that is available to meet the requirement for the temperature at start-up.

Engine oil viscosity		
EMA LGR-1 / MA LGR-1 / API CF, CF-4, CG-4, CH-4 / CI-4 Viscosity grade	Ambient temperature	
	Minimum	Maximum
SAE 0W20	-40°C (-40°F)	10°C (50°F)
SAE 0W30	-40°C (-40°F)	30°C (86°F)
SAE 0W40	-40°C (-40°F)	40°C (104°F)
SAE 5W30	-30°C (-22°F)	30°C (86°F)
SAE 5W40	-30°C (-22°F)	40°C (104°F)
SAE 10W30	-20°C (-4°F)	40°C (104°F)
SAE 15W40	-10°C (14°F)	50°C (122°F)

N.B.-:FOR ADDITIONAL ENGINE OIL RECOMMENDATIONS, REFER TO THE ENGINE MANUAL PROVIDED WITH THE MACHINE.

D - Operation instructions

9.2 - HYDRAULIC OIL

External environmental conditions can reduce performance of the machine if the hydraulic oil temperature does not reach its optimum range.

It is recommended to use the hydraulic oil according to weather condition. Refer to the table below.

Environmental conditions	SAE Viscosity grade
Ambient temperature between - 15°C (5°F) and + 40°C (+ 104°F)	HV 46
Ambient temperature between - 35°C (- 31°F) and + 35°C (+ 95°F)	HV 32
Ambient temperature between 0°C (+ 32°F) and + 45°C (+ 113°F)	HV 68

N.B.-:IT IS RECOMMENDED TO REPLACE LOW TEMPERATURE OIL AS THE AMBIENT TEMPERATURE REACHES + 15°C (59°F). IT IS NOT ADVISABLE TO MIX OILS OF DIFFERENT BRANDS OR TYPES.

9.3 - PREHEATING OPERATION

When power is switched on, the LED (102) at platform control display panel flashes, indicating that the engine is in automatic pre-heating mode. Upon the extinction of this light (just in seconds) at platform, starting of the machine is possible.

E - General Specifications



Notes

A

B

C

D

E

F

G

H

I

E - General Specifications

1 - Machine dimensions

Stowed / Transport position : Configuration that takes the minimum floor space necessary for storage and / or delivery of the machine - Access position.

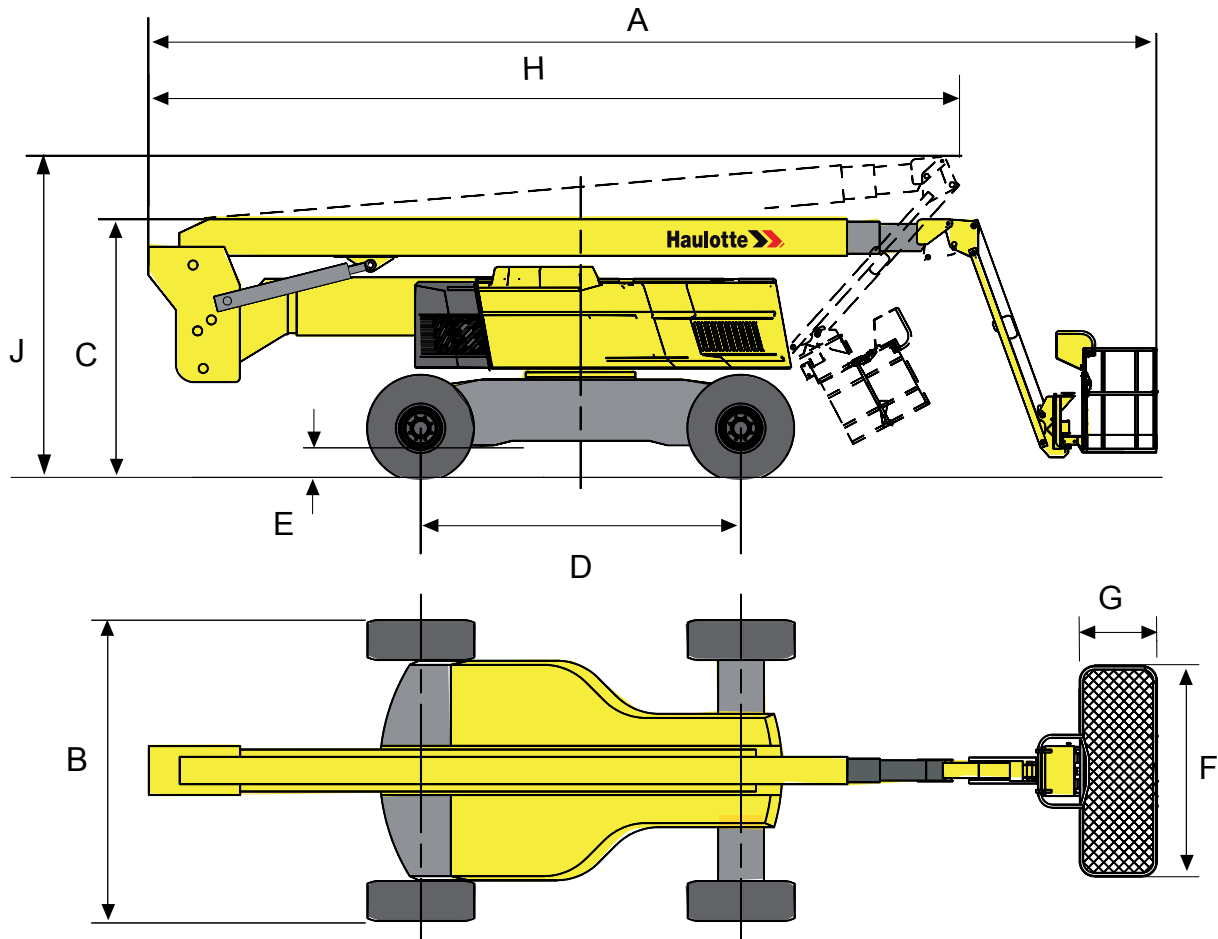

E - General Specifications

CE, AS and EAC standards

Machine		HA32RTJ PRO		HA41RTJ PRO	
Marking	Specifications - Dimensions	SI	Imp.	SI	Imp.
A	Overall length of machine	11,70 m	38 ft 5 in	13,10 m	43 ft 0 in
B	Overall width of machine	2,53 m	8 ft 3 in	2,53 m	8 ft 3 in
C	Overall height of machine	2,80 m	9 ft 2 in	2,99 m	9 ft 9 in
D	Wheel base	3,50 m	11 ft 5 in	3,50 m	11 ft 5 in
E	Ground clearance	38 cm	15 in	38 cm	15 in
F X G	Platform dimensions	2,44 x 0,915 m	8 ft 0 in x 3 ft 0 in	2,44 x 0,915 m	8 ft 0 in x 3 ft 0 in
F X G	For Japan only Platform dimensions :	1,50 x 0,8 m	4 ft 11 in x 2 ft 7 in	1,50 x 0,8 m	4 ft 11 in x 2 ft 7 in
H	Storage length	8,90 m	29 ft 2 in	11 m	36 ft 1 in
J	Storage height	3,60 m	11 ft 10 in	3,95 m	13 ft 0 in

ANSI and CSA standards

Machine		HA100RTJ PRO		HA130RTJ PRO	
Marking	Specifications - Dimensions	SI	Imp.	SI	Imp.
A	Overall length of machine	11,70 m	38 ft 5 in	13,10 m	43 ft 0 in
B	Overall width of machine	2,53 m	8 ft 3 in	2,53 m	8 ft 3 in
C	Overall height of machine	2,80 m	9 ft 2 in	2,99 m	9 ft 9 in
D	Wheel base	3,50 m	11 ft 5 in	3,50 m	11 ft 5 in
E	Ground clearance	38 cm	15 in	38 cm	15 in
F X G	Platform dimensions	2,44 x 0,915 m	8 ft 0 in x 3 ft 0 in	2,44 x 0,915 m	8 ft 0 in x 3 ft 0 in
F X G	For Japan only Platform dimensions :	1,50 x 0,8 m	4 ft 11 in x 2 ft 7 in	1,50 x 0,8 m	4 ft 11 in x 2 ft 7 in
H	Storage length	8,90 m	29 ft 2 in	11 m	36 ft 1 in
J	Storage height	3,60 m	11 ft 10 in	3,95 m	13 ft 0 in

E - General Specifications

2 - Major component masses

N.B.-:-MASSES MEASURED WITH EMPTY TANKS.

Component	HA32RTJ PRO - HA100RTJ PRO	HA41RTJ PRO - HA130RTJ PRO
Frame assembly mass	7190 kg - 15851 lb	
• Mass of each wheel	410 kg - 904 lb	
Turret assembly mass	3115 kg - 6867 lb	3460 kg - 7628 lb
• Counterweight mass - Turntable	2 x 1450 kg - 2 x 3197 lb	2 x 1850 kg - 2 x 4079 lb
• Engine mass + engine compartment	PERKINS engine : 554 kg + 100 kg - 1222 lb + 220 lb	
• Battery mass	45 kg - 99 lb	
Arm assembly mass	2600 kg - 5730 lb	4520 kg - 9960 lb
Boom assembly mass	2130 kg - 4695 lb	2585 kg - 5700 lb
Jib assembly mass	168 kg - 370 lb	170 kg - 375 lb
Platform assembly mass	192 kg - 423 lb (Basket with a sliding bar) 198 kg - 437 lb (Basket with a door)	

3 - Acoustics and vibrations

The acoustics and vibrations specifications are based upon the following conditions :

- The airborne noise emissions at workstation are determined per European Directive 2006/42/CE.
- The guaranteed sound power level LWA (displayed on the product) is determined per European Directive 2000/14/CE.
- The vibrations transmitted by the machinery to the hand/arm system and to the whole body are determined per European Directive 2006/42/CE.

Specifications	
Sound pressure level at workstation	≤ 74 dBA
Guaranteed sound power level	108 dBA
Vibrations hand/arm	Vibration transmitted by this MEWP to the hand-arm does not exceed 2,5 m/s ² (98,4 in/s ²)
Vibrations whole body	Vibration transmitted by this MEWP to the whole body does not exceed 0,5 m/s ² (19,6 in/s ²)

E - General Specifications

4 - Wheel/Tire assembly

4.1 - TECHNICAL SPECIFICATIONS

Component	Standard wheel
Reference number	OTR 445/65-22.5 18 plys
Type	Foam-filled
Wheel mass	387 kg - 0, + 37 kg (853 lb - 0, + 82 lb)
Size	Diameter : 1100 mm +/- 80 mm (44 in +/- 4 in) Width : 438 mm +/- 20 mm (18in +/- 1 in)
Torque	650 Nm (479 ft lb)

4.2 - INSPECTION AND MAINTENANCE

Replace the wheels and the tires if any of the following conditions exist :

- Presence of cracks, damage, deformation or other faults on the hub
- Damage to the tire :
- Cut or hole > 3 cm (2 in) in the rubber side wall.
- Blister or pronounced lump on the external and lateral wall.
- Damaged wheel stud.
- Damage or wear on the side wall to the extent that the reinforcing wire is visible.
- Consistent wear of the ground contact surface greater than 25%

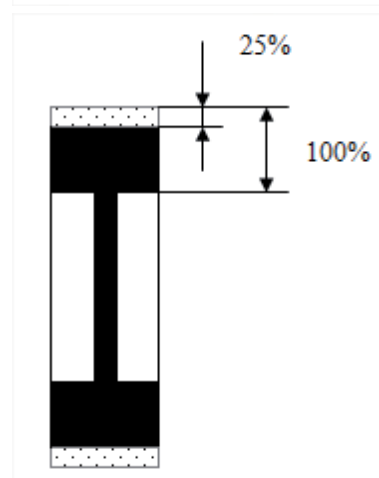
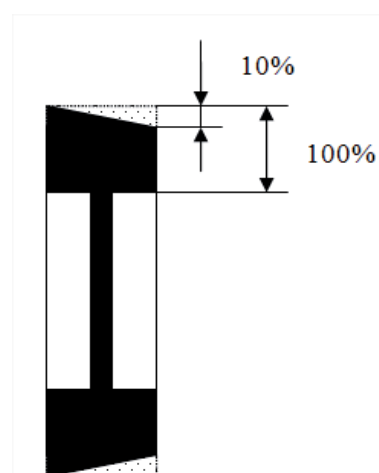

E- General Specifications



Tires and rims are critical components for the stability of the machine. For safety reasons :

- Use only HAULOTTE® spare parts according to the technical characteristics of the machine. Refer to the spare parts catalog.
- Do not replace factory-installed tires with tires of different specifications or ply rating.
- Never replace foam filled tire with a pneumatic (air filled) tire.

Procedure of replacement :

- Loosen the wheel nuts on the wheel to be removed.
- Raise the machine using a jack or a hoist.
- Remove the wheel nuts.
- Remove the wheel.
- Install the new wheel.
- Lower the machine to the ground.
- Tighten the wheel nuts to the recommended torque Refer to maintenance and repair manuals.

N.B.-:-IF A WHEEL HAS BEEN REPLACED, WHILE OBSERVING THE AXLE TRACK PATTERN CHECK FOR CORRECT INSTALLATION.

E - General Specifications

5 - Options

5.1 - ON-BOARD GENERATOR

5.1.1 - Principle

The on-board generator supplies voltage (220 V or 110 V depending; on the option) in the basket to connect a power tool.



Check that the maximum power of the tool doesn't exceed that of the generator.



Do not expose the on-board generator to direct contact with a water beam or a high pressure cleaner.

5.1.2 - Procedure

Put into service :

1. Start the machine. Heat the engine for 15 mn before any operation.
2. From the platform control box, move the generator selector switch ((79)) to the right to activate the generator
3. Connect the tool to the socket.
4. You can change the tool at any time.

N.B.-:WHEN USING THE ON-BOARD GENERATOR, YOU CANNOT MAKE ANY MACHINE MOVEMENTS. TO MAKE A MOVEMENT, YOU MUST SWITCH OFF THE ON-BOARD GENERATOR.

Power off :

5. Disconnect the tool from the socket.
6. From the platform control box, activate the selector switch (79) to the right to activate generator.
7. Machine movements are once again functional.



E- General Specifications

5.2 - WELDER'S KIT

5.2.1 - Description

This carrier is designed for installing a welder (model type Miller CS280) on the carrier installed on the platform. The welder unit must be correctly attached to the carrier using the supplied flanges.

5.2.2 - Characteristics

Component	Characteristics
Weight of the carrier	10 kg (22 lbs)
Maximum weight of the welding station (Carrier + welder)	30 kg (65 lbs)

5.2.3 - Safety precautions



- Please read and assimilate the instructions before using the attachment.
- Do not use this attachment for installing any other type of welder unit. This attachment is specifically designed for the welder model type Miller CS280
- Do not overload the carrier. Ensure that the carrier is secured to the platform and welder is retained with the fastening plate.
- Do not exceed the maximum allowable platform capacity. The combined weight of the attachment, the welding station, the occupants, the tools and any other equipment must not exceed the maximum allowable platform capacity.
- The carrier should always be positioned so that it is within the platform.

5.2.4 - Pre-operation inspection



- Check that the carrier has no cracks or other damage.
- Check that the carrier is correctly installed and secured to the platform.
- Check that the information decal is present on the carrier and is legible.

5.2.5 - Operation

- Load the welding station onto the carrier.
- Securely attach the welding station to the carrier using the flanges supplied.

E - General Specifications

5.2.6 - Assembly - Dis-assembly

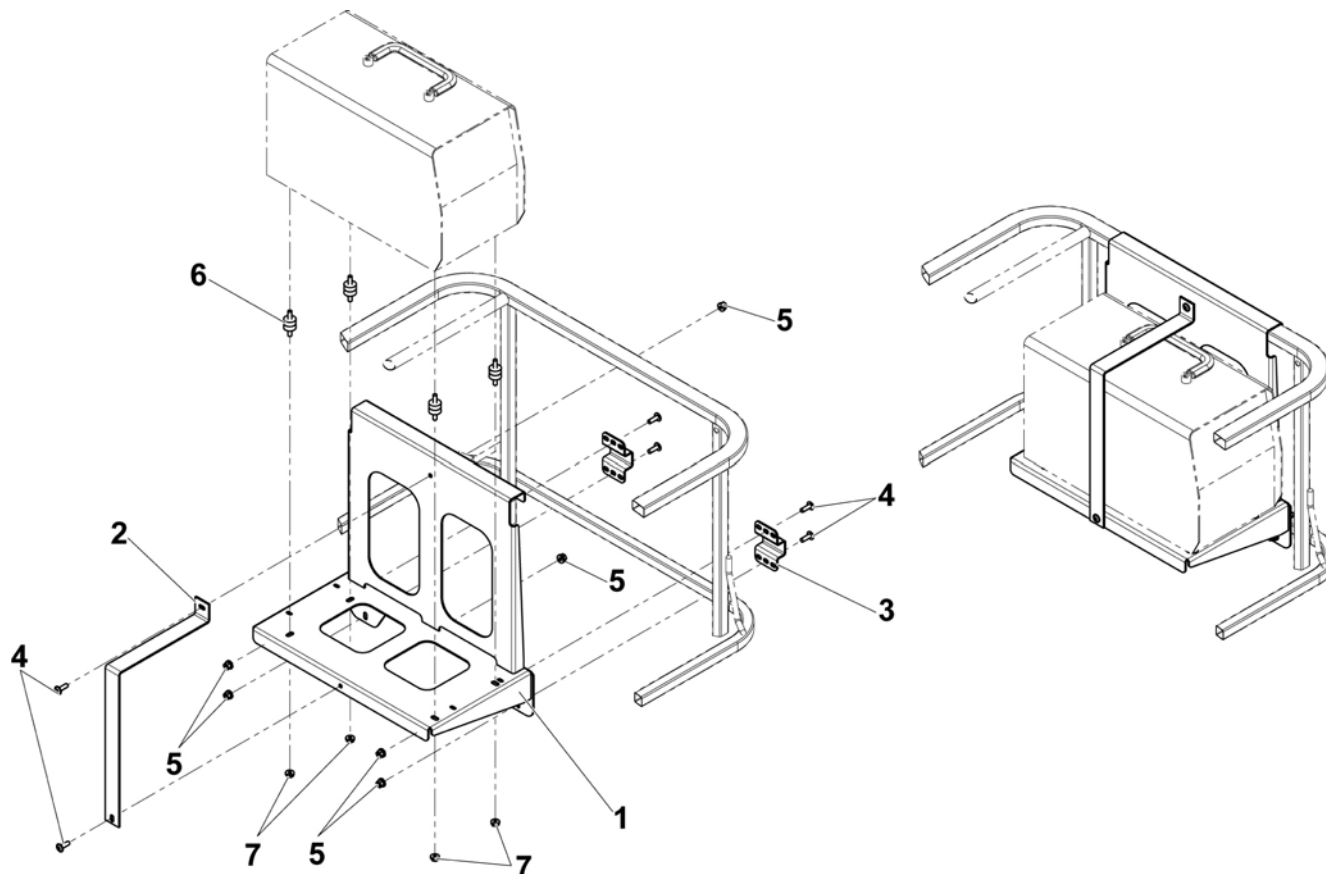

Marking	Description
1	Carrier
2	Fastening plate
3	Flange
4	Screws
5	Nuts
6	Rubber block
7	Nuts

- Place the carrier (1) flange over the top of the horizontal guardrail tube.
- Using the 2 flanges (3), 4 screws (4) and 4 locknuts (5), secure the carrier to the intermediate horizontal guardrail tube.
- Tighten the hardware to the recommended torque.

N.B.-:TORQUE REQUIREMENTS : 22 Nm (15 FT LBS)

- Place the welder on the carrier (1).
- Secure the welder to the carrier using 4 rubber blocks (6), 4 nuts (7), 6 nuts (5) and fastening plate (2).
- Install the fastening plate (2) over the welder and secure it to the carrier with 2 screws (4) and 2 nuts (5).

E- General Specifications

5.2.7 - Specific decals

Location of the decals

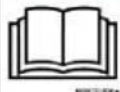
		<p>DANGER - PELIGRO</p> <p>OVERTURNING HAZARD</p> <p>Do not exceed platform capacity in combining weight of occupants, tools, support, materials and any other equipment. Secure firmly support to platform and material to support. Failure to comply will result in death or serious injury.</p>	<p>RISQUE DE RENVERSEMENT</p> <p>Ne pas dépasser la capacité de la nacelle en combinant la masse des occupants, des outils, du support, des matériaux et de tout autre équipement. Attacher fermement le support à la nacelle et le matériel sur le support. Le non-respect des instructions causera des blessures graves ou mortelles.</p>	<p>RIESGO DE VUELCO</p> <p>No sobrepasar la capacidad de la plataforma combinando a la masa de los ocupantes, los instrumentos, del soporte, los materiales y de otro equipo. Atar firmemente el soporte a la barquilla y el material sobre el soporte. El no respeto de las instrucciones causará heridas graves o mortales.</p>
---	---	--	--	--

1

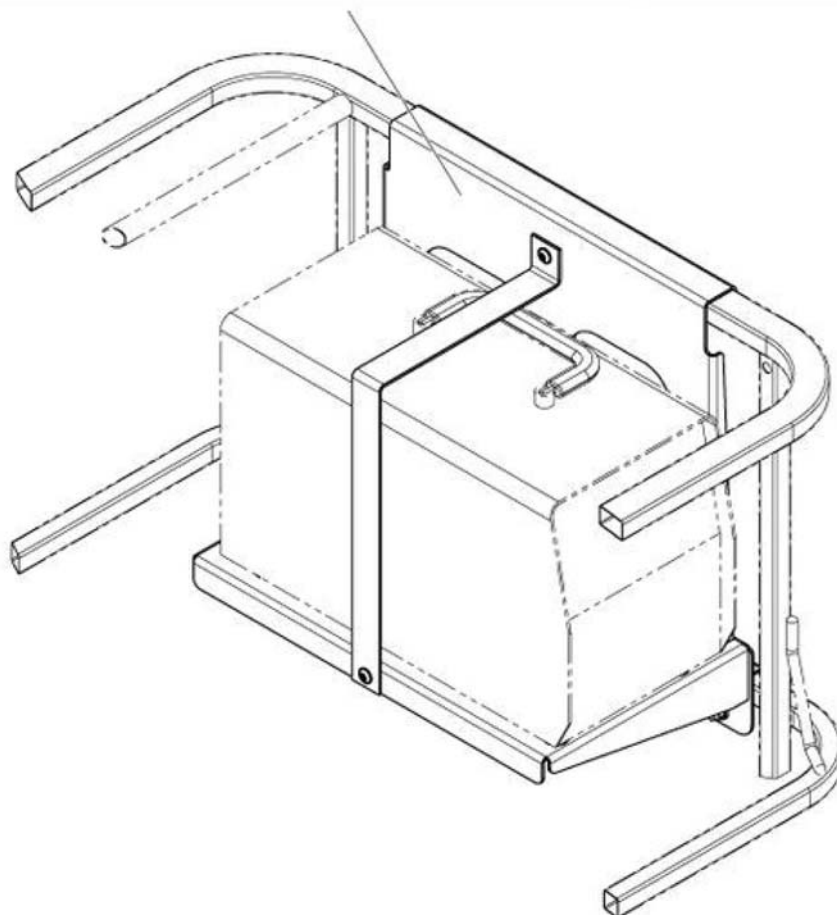

Marking	Description	Quantity	Part number
1	Risk of overturning	1	4000131830

E - General Specifications

5.3 - PLUMBER'S KIT

5.3.1 - Description

This attachment is an assembly designed to transport pipes and tubes. The assembly comprises of 2 cradles securely attached to the platform. The load (material) should be placed in both the cradles and secured with a strap (not supplied).

5.3.2 - Characteristics

Component	Characteristics
Weight of the carrier	8 kg (20 lbs)
Weight of the equipment on the carrier	80 kg (175 lbs)
Maximum load surface	0,8 m ² (Ø 0,32 m x 2,5 m) / 8.6 sq.ft (Ø 1 ft x 8.6 ft)
Maximum wind speed allowed	12,5 m/s - 45 km/h - 28 mph

5.3.3 - Safety precautions



- Please read and assimilate the instructions before using the attachment.
- This attachment is designed for transporting pipes and tubes. Do not use this attachment for transporting other types of load. .
- Do not suspend loads.
- Do not overload the attachment and ensure that the equipment is correctly attached by means of a strap (not supplied).
- Do not exceed the maximum allowable platform capacity. The combined weight of the attachment, load, the occupants, the tools and any other equipment must not exceed the maximum allowable platform capacity.
- Do not load tubes whose surface area exceeds the maximum authorized surface area. Exposing an additional surface area to the wind reduces machine stability. Do not install any other attachments that increase the surface area exposed to the wind.
- Do not use the machine if the wind speed exceeds the authorized limit of the attachment.
- The cradles should always be positioned such that they are within the platform. Position the bottom end of the cradles such that they are resting on the platform floor.
- When maneuvering, ensure you maintain a safe distance between the load and the obstacles in the work environment.

5.3.4 - Pre-operation inspection



- Check that the cradle has no cracks or other damage.
- Check that the cradle is correctly installed and secured to the platform.
- Check that the information decal is present on the cradle and is legible.
- Check that the strap is not twisted or torn.
- Check that the position of the load and attachment is not obstructing access to the platform or the controls.
- Check that the position of the attachment and the load is not reducing visibility during maneuvers in the work environment.

E- General Specifications

5.3.5 - Operation

- Position the load to rest on the 2 cradles.
- Center the load on the cradles.
- Securely attach the load to each cradle with strap of adequate strength and dimensions.

Strapping example(s)



5.3.6 - Assembly - Dis-assembly

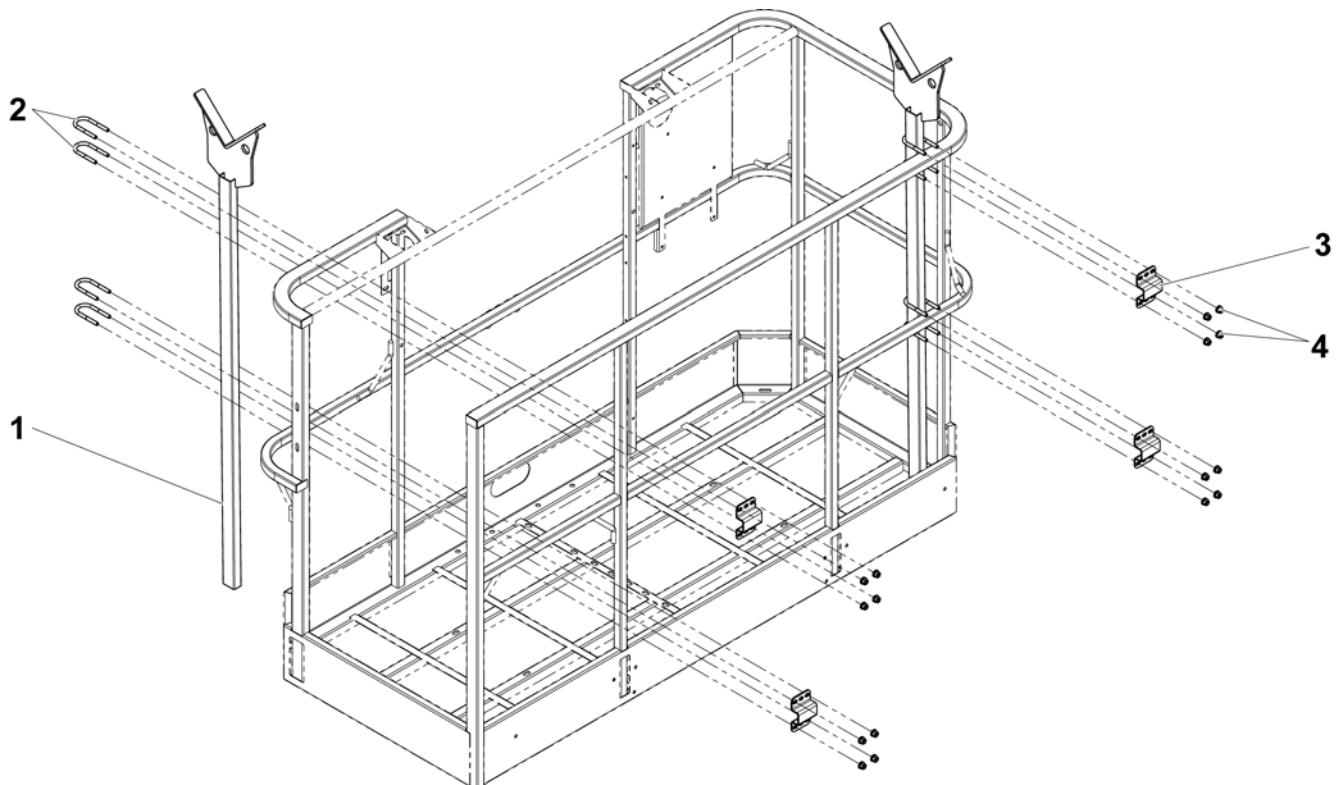

Marking	Description
1	Cradle
2	Fastening screw U bolt
3	Flange
4	Nuts

E- General Specifications

- Locate the cradles such that the load will be parallel to the length of the platform.
- Install two cradles (1) to the guardrails using 4 supplied flanges (3).
- Tighten up the flange using 2 supplied screw U bolts (2) and 4 nuts (4), wherever a cradle and the horizontal guardrail tubes intersect.

N.B.-:TORQUE REQUIREMENTS : 22 Nm (15 FT LBS)

- Ensure that the bottom of cradle is resting on the platform floor.
- Ensure that the distance between the 2 cradles support and center the load.
- Pre-operation test : Place and secure the load of 120 kg (265 lbs) on the cradles. Ensure that the cradles can support the load and that there is no visual structural damage.

5.3.7 - Specific decals, optional

Location of the decals

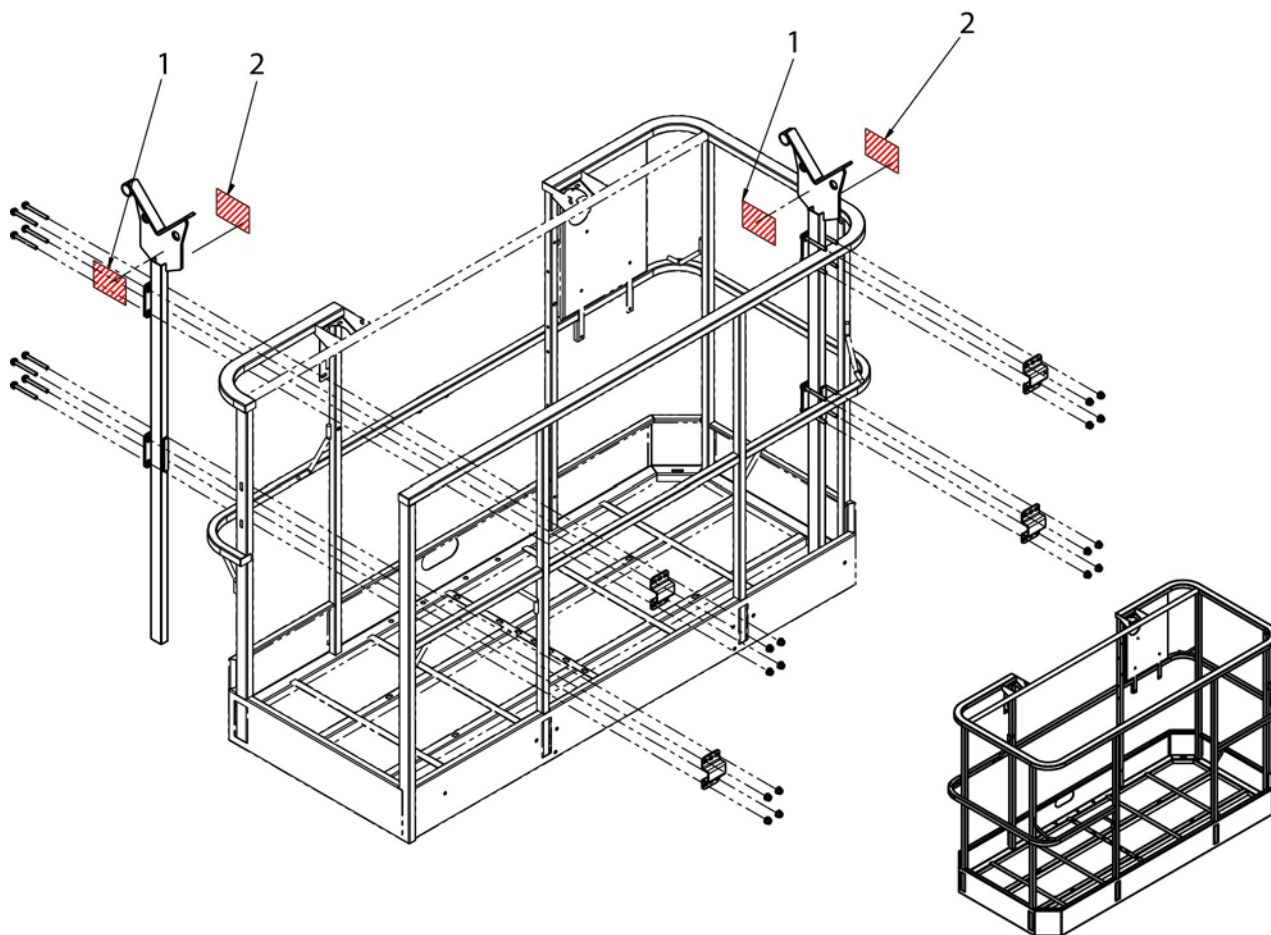

Marking	Description	Quantity	Part number
1	Risk of overturning	2	In english 4000131600 In french 4000131610 In spanish 4000131620 In german 4000708570
2	Equipment characteristics	2	4000131650

E- General Specifications

5.4 - ACTIV' SHIELD BAR - SECONDARY GUARDING SYSTEM (IF FITTED)

5.4.1 - Description



General Specification Activ' Shield Bar :

- The Activ' Shield Bar is a device designed to reduce the risk of entrapment against the control panel when the platform is in confined spaces.
- This device is complementary to the existing operator protection including the enable switch system (Trigger of joystick, Foot Switch and Enable Switch on ground control box).
- The Activ' Shield Bar is active when the platform is elevated (boom or arm) and creep speed is automatically engaged. It is not enabled when stationary or in the transport position, when drive, turret rotation and jib raise are possible.
- The green indicator light of the Activ' Shield Bar is illuminated indicating the device is active :
- Light flashing : Machine stationary in Activ' Shield Bar zone (The platform is elevated and the Activ' Shield Bar will be active during movements).
- Light on : Activ' Shield Bar is active.



This system does not relieve the operator from the responsibilities of learning and practicing the principles of safe use and operation of the machine as provided by the manufacturer's instructions, employer's safety rules and worksite regulations

5.4.2 - Characteristics

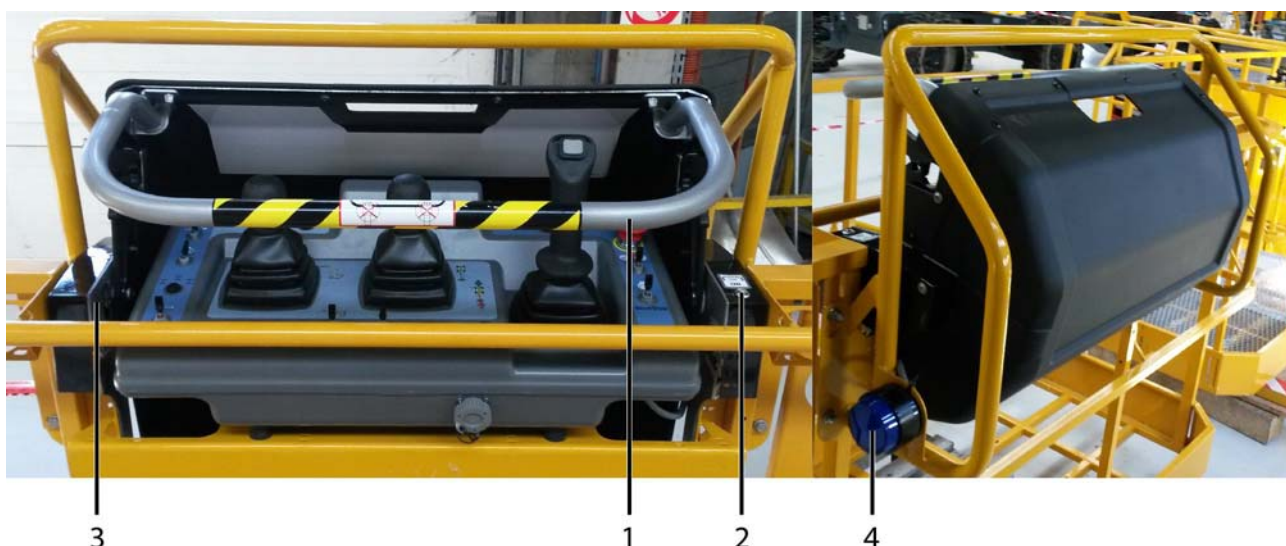

Marking	Description
1	Activation bar
2	Green indicator light
3	Sensor
4	Blue flashing light

E - General Specifications

5.4.3 - Safety precautions



It is mandatory to ensure that the **Activ' Shield Bar** is functional at each start-up of the machine



Do not use the **Activ' Shield Bar** as a handhold. This could result in an inadvertent triggering of the **Activ' Shield Bar**.

- Check the work area for overhead clearances, obstructions or other possible hazards.
- When driving, position the platform so as to provide the best visibility possible and avoid any blind spots.
- Always ensure that the chassis is never driven any closer than 1 m (3 ft3 in) from holes, bumps, tilts, obstructions, debris and ground coverings that may hide dangers.
- During operation, keep all the parts of the body inside the platform.
- To position the machine close to obstacles, it is recommended to use boom movements (arm, boom, etc.) instead of the drive movements.
- Do not drive fast in narrow or cluttered areas. Keep speed under control while making turns or sharp bends.

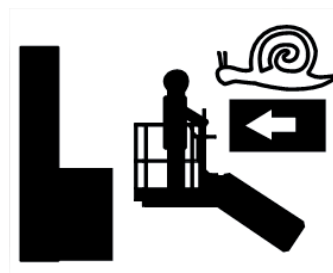
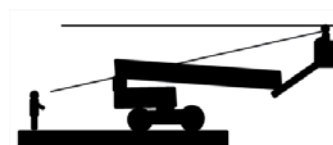

E- General Specifications

5.4.4 - Pre-operation inspection



- If any item on the checklist is marked NO during the inspection; machine must be tagged and locked out and placed out of service.
- DO NOT operate the machine until all identified items are corrected and it has been declared safe for operation.

Description	Yes	No
Perform all specified machine functional tests		
• All machine functional tests result positive		
Start the machine from platform control box		
Switch off (push in) all the emergency stop buttons		
• Check absence of warning signal		
• Check that the blue indicator (4) is not activated when the machine is in stowed position		
To ensure Activ' Shield Bar device is functioning correctly, perform the following :		
When stowed :		
• Check that the green indicator light (2) is not illuminated		
When boom or arm is raised above 15° :		
• Check that the green indicator light (2) is blinking-With platform stationary.		
• Check that the green indicator light (2) is illuminated-With platform in motion.		
Simultaneously make a movement and push forward the activation bar to trigger the system :		
• Check that all movements stop.		
• Check that the horn and the blue flashing light (4) are activated.		

N.B.-:-PRESS THE FOOT SWITCH TO RESET THE SYSTEM

5.4.5 - Operation

If the Activ' Shield Bar is pushed forward, all movements are stopped. The horn sounds and the warning blue light flashes. Only movements to move away from the entrapment are authorised.

To re-set the Activ' Shield Bar, release the activation bar, the Foot Switch and controls. Then, re-press the Foot Switch.

Care must be taken during all operations to prevent collision and entrapment against structures.

E - General Specifications

5.4.6 - Specific decals

Location of the decals

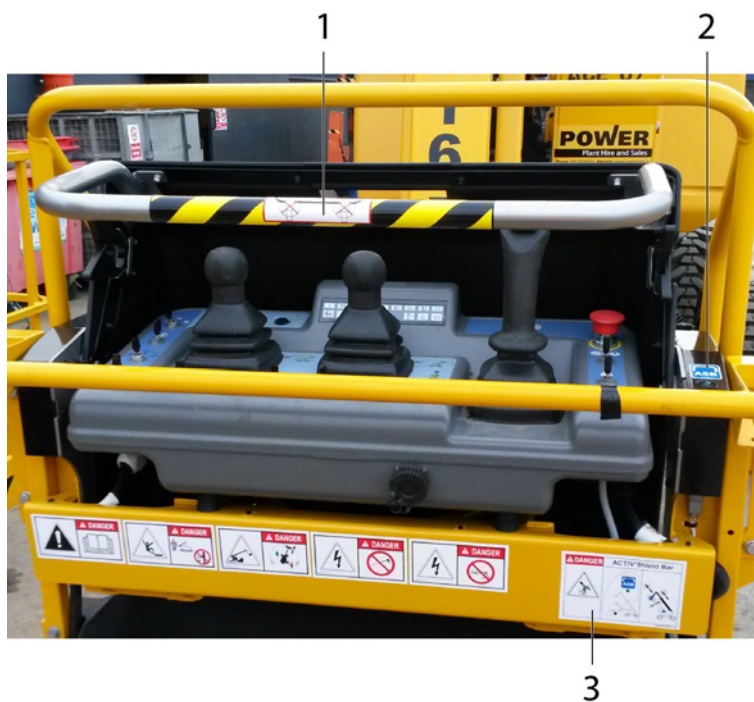

Marking	Description	Quantity	Part number
1	Do not lean on the bar	1	4000206690
2	Activ' Shield Bar controls	1	4000596720
3	Activ' Shield Bar instructions	1	4000609540

Activ' Shield Bar instructions

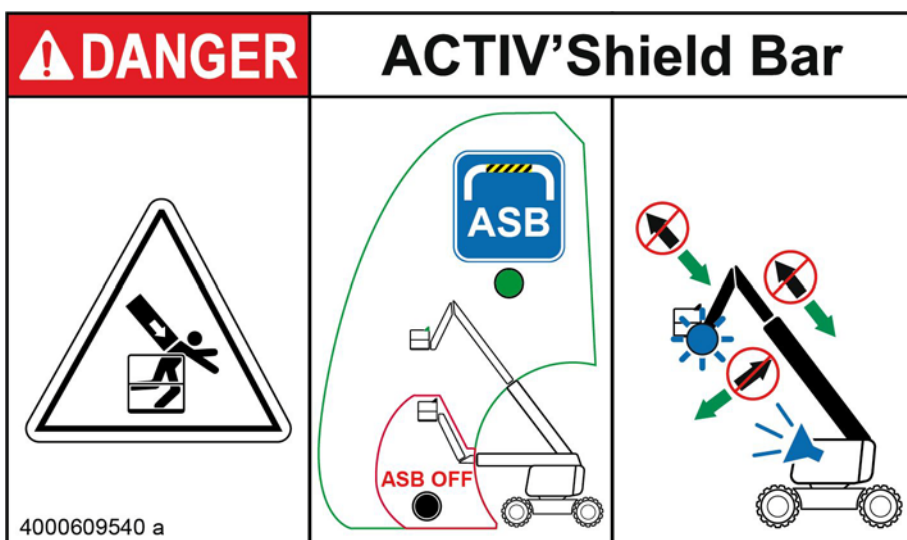

E- General Specifications

5.5 - SWING GATE

5.5.1 - Description

"SWING GATE" consists of a laterally mounted pivoting $\frac{1}{2}$ gate with closing latch, which enables a better access to platform. Spring loaded hinges and a latching mechanism allows the gate to swing inwards only.

Swing gate



5.5.2 - Characteristics

Width of the gate : 500 mm / 19.68 in

5.5.3 - Safety precautions



- The gate is part of the guardrail system and must be securely fastened after entering the platform.
- Pay attention to the toeboard when entering or leaving the platform.

5.5.4 - Pre-operation instructions

- Inspect that the latching mechanism is securely fastened.
- Check the hinges and latch operate correctly and are not deformed.
- Ensure that the gate returns automatically to the closed and fastened position after entering or exiting the platform.

F - Maintenance

1 - General

As an owner and/or operator of Haulotte equipment, your Safety is of utmost importance to HAULOTTE®, which is why HAULOTTE® places such a high priority on product safety.

INSPECTIONS are not only required by HAULOTTE®, but may also be required by industry standards and/or local regulations.

To ensure your equipment continues to achieve the level of performance set in the factory, it is important to maintain it regularly. We remind you that it is strictly forbidden to make any modifications. Regular and timely inspections will reduce equipment down time as well as prevent possible injury.

N.B.-:DO NOT OPERATE UNLESS YOU ARE FAMILIAR AND TRAINED IN THE PRINCIPLES OF SAFE MACHINE OPERATION.

Overview :

- Walk-around inspections take only a few minutes at the beginning and end of each shift – one of the best ways to prevent mechanical problems and safety hazards.

What to Do :

- Use your senses: sight, smell, hearing and touch.

Frequency :

- Check your machine periodically during your entire workday.
- Make sure to do your inspection the same way every time.
- Complete one of these inspections at the start and end of each shift.

N.B.-:IF DAMAGE OR UNAUTHORIZED MODIFICATIONS ARE DISCOVERED, THE MACHINE MUST BE REMOVED FROM SERVICE UNTIL REPAIRS ARE MADE BY A QUALIFIED SERVICE TECHNICIAN.

It is the owner's responsibility to ensure the required maintenance as recommended by Haulotte is completed prior to the operation of the machine.

If regular maintenance is not carried out, this may :

- Void the warranty.
- Cause machine malfunction.
- Reduce machine reliability and shorten its service life.
- Jeopardize operator safety.

HAULOTTE Services® technicians are specially trained to carry out extensive repairs, interventions or adjustments on the safety systems or elements of HAULOTTE® machines. They carry genuine HAULOTTE spare parts and tools as required, and also provide fully documented reports on all work completed.

The inspection and maintenance table, identifies the role and the responsibilities of each party in periodical machine maintenance.  Section C 3 - Inspection and Functional test.

F - Maintenance

2 - Maintenance Schedule

This section provides the necessary information needed to place the machine in safe operation. In accordance with the regulations that are currently applicable, this machine is designed to have a 10 year life span in normal usage conditions. The life may be extended or reduced dependent on the severity of operating conditions, the machine condition itself and by conducting effective inspections and maintenance in addition to other external factors. There are a number of factors which can affect the design life including but not limited to, severity of operating conditions/routine maintenance which should be carried out in accordance with this manual.

Severity of operating conditions may require a reduction in time between maintenance periods. Machines that have been out of service or have not been in use for more than 3 months must undergo a periodic inspection before the machine is put back into service.

Maintenance must be carried out by a competent company or person familiar with mechanical procedures.

Maintenance operations performed must be recorded in a register / log book of the machine.

3 - Inspection program

3.1 - GENERAL PROGRAM

The machine must be inspected on a regular basis at intervals of no less than once 1 per year. The purpose of the inspection is to detect any defect which could lead to an accident during routine use of the machine. Local standards and regulations may require more frequent inspections.

HAULOTTE® requires Reinforced and Major Inspections to be carried out on the product to extend its service life.

Inspections must be carried out by a competent company or person.

The inspection results must be recorded in the safety register or machine log book controlled and overseen by the company manager. This register or machine log book and the list of competent repair persons must be made available to the government work inspector and HAULOTTE Services®.

When	Responsible	Stakeholder	What
Before sale	Owner (or renter)	Competent technician or qualified technician HAULOTTE Services®	Periodic inspection
Before rent	Owner (or renter)	Competent technician or qualified technician HAULOTTE Services®	Daily inspection
Before use or every change of user	User	User	
Annually (1 year)	Owner (or renter)	Competent technician or qualified technician HAULOTTE Services®	Periodic inspection
5 years	Owner (or renter)	Qualified technician HAULOTTE Services®	Reinforced inspection
10 years	Owner (or renter)	Qualified technician HAULOTTE Services®	Major inspection

F - Maintenance

3.2 - DAILY INSPECTION

The Daily inspection includes a visual inspection, operational checks and testing of the safety systems. This must be conducted by the operator before using the machine.

This inspection is the responsibility of the user. Refer to  Section C 3.1 - Daily inspection.

3.3 - PERIODIC INSPECTION

The Periodic inspection is a thorough evaluation of the operation and safety features of the machine.

It must be conducted before the sale / resale of the machine and/or at least once every year.

Local regulations may have specific requirements on frequency, and content of inspections.

The severity of operating conditions may require frequent inspections.

This inspection is the responsibility of the owner, and inspections must be carried out by a competent company or person.

This inspection is in addition to the daily inspection.

This inspection should also be conducted after :

- Extensive dismantling and reassembly of major components.
- Repairs involving the machine's essential components.
- Any accident causing stress to the machine.

3.4 - REINFORCED INSPECTION

The Reinforced inspection is a thorough evaluation of the machine's structural components, to ensure proper functionality of the machine.

This evaluation must occur at a frequency of 5000 hours or every 5 years.

This inspection is the responsibility of the owner, and it must be conducted by a HAULOTTE Services® technician or by a competent company or person.

This inspection includes :

- Daily inspection
- Periodic inspection

N.B.-:-REFER TO THE MAINTENANCE MANUAL FOR DETAILS.

F - Maintenance

3.5 - MAJOR INSPECTION

The Major inspection is a thorough evaluation of the machine's integrity and proper functioning; after a normal service life of 10 years.

This evaluation must take place after 10 years of operation and then repeated every 5 years thereafter.

The severity of operating conditions may require frequent inspections.

This inspection is the responsibility of the owner, and it must be conducted by a HAULOTTE Services® technician or by a competent company or person.

This inspection includes :

- Daily inspection
- Periodic inspection
- Reinforced inspection

N.B.-:REFER TO THE MAINTENANCE MANUAL FOR DETAILS.

F - Maintenance

4 - Repairs and adjustments

Extensive repairs, interventions or adjustments on the safety systems or components must be performed by a HAULOTTE Services® technician. Use original spare parts and components only.

N.B.-:HAULOTTE SERVICES® TECHNICIANS ARE TRAINED PROFESSIONALS TO PERFORM EXTENSIVE REPAIRS, INTERVENTIONS AND ADJUSTMENTS ON THE SAFETY SYSTEMS OR COMPONENTS OF HAULOTTE® MACHINES. THE TECHNICIAN CARRIES GENUINE HAULOTTE® SPARE PARTS AND TOOLS AS REQUIRED, AND ALSO PROVIDES FULLY DOCUMENTED REPORTS ON ALL WORK COMPLETED.

HAULOTTE Services® will not take responsibility for any outcomes resulting from inferior services or repairs performed by other unauthorised personnel.

HAULOTTE® reminds that NO modifications SHALL be carried out without the written permission of HAULOTTE®.

Any unauthorised repairs/modifications will void HAULOTTE® warranty.

To check for safety campaigns, consult our website : www.haulotte.com



N.B.-:WHEN DISPOSING OR SCRAPPING THIS MACHINE, PLEASE CONSIDER APPROPRIATE METHODS OF RECYCLING. ANY ITEMS THAT REQUIRE SPECIFIC DISPOSAL ARE LISTED WITH INSTRUCTIONS IN THE MAINTENANCE MANUAL.

F - Maintenance



Notes

G- Other information

1 - Conditions of warranty

Our warranty conditions and extension contracts are now available on the websites of our sales network : www.haulotte.com







2 - Subsidiary contact information

	<p>HAULOTTE FRANCE PARC DES LUMIERES 601 RUE NICEPHORE NIEPCE 69800 SAINT-PRIEST TECHNICAL Department: +33 (0)820 200 089 SPARE PARTS : +33 (0)820 205 344 FAX : +33 (0)4 72 88 01 43 E-mail : haulottefrance@haulotte.com www.haulotte.fr</p>		<p>HAULOTTE ITALIA VIA LOMBARDIA 15 20098 SAN GIULIANO MILANESE (MI) TEL: +39 02 98 97 01 FAX: +39 02 9897 01 25 E-mail : haulotteitalia@haulotte.com www.haulotte.it</p>		<p>HAULOTTE INDIA Unit No. 1205, 12th floor, Bhumiraj Costarica, Plot No. 1&2, Sector 18, Palm Beach Road, Sanpada, Navi Mumbai- 400 705 Maharashtra, INDIA Tel. : +91 22 66739531 to 35 E-mail : hlindia@haulotte.com www.haulotte.in</p>
	<p>HAULOTTE HUBARBEITSBÜHNEN GmbH Ehrenkirchener Strasse 2 D-79427 ESCHBACH TEL : +49 (0) 7634 50 67 - 0 FAX : +49 (0) 7634 50 67 - 119 E-mail : adv-gmbh@haulotte.com www.haulotte.de</p>		<p>HAULOTTE VOSTOK 61A, bld.1, RYABINOVAYA STREET 121471 MOSCOW RUSSIA TEL/FAX : +7 495 221 53 02 / 03 E-mail : salesrus@haulotte.com www.haulottevostok.ru</p>		<p>HAULOTTE DO BRASIL Av. Alameda Caiapós, 589 CEP: 06460-110 – TAMBORE BARUERI – SAO PAULO – BRASIL TEL : +55 11 4196 4300 FAX : +55 11 4196 4316 E-mail : haulottebrasil@haulotte.com www.haulotte.com.br</p>
	<p>HAULOTTE IBERICA C/ARGENTINA Nº 13 - P.I. LA GARENA 28806 ALCALA DE HENARES MADRID TEL : +34 902 886 455 TEL SAT : +34 902 886 444 FAX : +34 911 341 844 E-mail : iberica@haulotte.com www.haulotte.es</p>		<p>HAULOTTE POLSKA Sp. Z.o.o. UL. GRANICZNA 22 05-090 RASZYN - JANKI TEL : +48 22 720 08 80 FAX : +48 22 720 35 06 E-mail : E-mail : haulottepolska@haulotte.com www.haulotte.pl</p>		<p>HAULOTTE MÉXICO, S.A. de C.V. Calle 40 SUR ESQUINA 13 ESTE No. S/N Colonia CIVAC, JUITEPEC, MORELOS CP 62578 México TEL : +52 77 7321 7923 FAX : +52 77 7516 8234 E-mail : haulotte.mexico@haulotte.com www.haulotte.com.mx</p>
	<p>HAULOTTE in JAPAN SBJ ShinOsaka BLDG 3F 4-6-5 Nishinakajima Yodogawa-ku, Osaka, JAPAN, Post Code: 532-0011 TEL : +81 6 6795 9008 FAX : +81 6 6795 9009 www.haulotte.com</p>		<p>HAULOTTE SINGAPORE Pte Ltd. No.26 CHANGI NORTH WAY, SINGAPORE 498812 Parts and service Hotline: +65 6546 6150 FAX : +65 6536 3969 E-mail : haulotteasia@haulotte.com www.haulotte.sg</p>		<p>HAULOTTE MIDDLE EAST FZE PO BOX 293881 Dubai Airport Free Zone DUBAÏ United Arab Emirates TEL : +971 (0)4 299 77 35 FAX : +971 (0) 4 299 60 28 E-mail : haulottemiddle-east@haulotte.com www.haulotte.ae</p>
	<p>HAULOTTE SCANDINAVIA AB Taljegårdsgatan 12 431 53 Mölndal SWEDEN TEL : +46 31 744 32 90 FAX : +46 31 744 32 99 E-mail : info@se.haulotte.com spares@se.haulotte.com www.haulotte.se</p>		<p>HAULOTTE TRADING (SHANGHAI) Co. Ltd. #7 WORKSHOP No 191 HUA JIN ROAD MIN HANG DISTRICT SHANGHAI 201108 CHINA TEL : +86 21 6442 6610 FAX : +86 21 6442 6619 E-mail : haulotteshanghai@haulotte.com www.haulotte.cn</p>		<p>HAULOTTE ARGENTINA Ruta Panamericana Km. 34,300 (Ramal A Escobar) 1615 Gran Bourg (Provincia de Buenos Aires) Argentina TEL : +54 33 27 445991 FAX : +54 33 27 452191 E-mail : haulotteargentina@haulotte.com www.haulotte.com.ar</p>
	<p>HAULOTTE UK Ltd 1 Gravely Way Four Ashes Wolverhampton WV10 7GW ENGLAND TEL : +44 (0)1216 199753 FAX : +44 (0)1952 292758 E-mail : salesuk@haulotte.com www.haulotte.co.uk</p>		<p>HAULOTTE GROUP / BILJAX 125 TAYLOR PARKWAY ARCHBOLD, OH 43502 – USA TEL : +1 419 445 8915 FAX : +1 419 445 0367 Toll free : +1 800 537 0540 E-mail : sales@us.haulotte.com www.haulotte-usa.com</p>		<p>HAULOTTE NORTH AMERICA 3409 Chandler Creek Rd. VIRGINIA BEACH, VA 23453 – USA TEL : +1 757 689 2146 FAX : +1 757 689 2175 Toll free : +1 800 537 0540 E-mail : sales@us.haulotte.com www.haulotte-usa.com</p>
	<p>HAULOTTE NETHERLANDS BV Koopvaardijweg 26 4906 CV OOSTERHOUT - Nederland TEL : +31 (0) 162 670 707 FAX : +31 (0) 162 670 710 E-mail info@haulotte.nl www.haulotte.nl</p>		<p>HAULOTTE AUSTRALIA PTY Ltd 51 Port Link Drive DANDENONG – VIC – 3175 TEL : 1 300 207 683 FAX : +61 (0)3 9792 1011 E-mail : sales@haulotte.com.au www.haulotte.com.au</p>		<p>HAULOTTE CHILE Panamerica Norte Altura Km 21,5 Colina (Cruce c/Lo Pinto) Santiago (RM) TEL : + 562 2 3727630 E-mail : haulotte-chile@haulotte.com www.haulotte-chile.com</p>

G- Other information

2.1 - CALIFORNIA WARNING

For the US destined machines (ANSI and CSA standards)

<p>CALIFORNIA</p> <p> Proposition 65 Warning</p> <p>Operating, servicing and maintaining a passenger vehicle or off-road vehicle can expose you to chemicals including engine exhaust, carbon monoxide, phthalates, and lead, which are known to the State of California to cause cancer and birth defects or other reproductive harm. To minimize exposure, avoid breathing exhaust, do not idle the engine except as necessary, service your vehicle in a well-ventilated area and wear gloves or wash your hands frequently when servicing your vehicle.</p> <p>For more information go to  www.P65Warnings.ca.gov/passenger-vehicle</p>
<p>CALIFORNIE</p> <p> Avertissement de la Proposition 65</p> <p>L'exploitation, l'entretien et la maintenance d'un véhicule de tourisme ou d'un véhicule tout-terrain peuvent vous exposer à des produits chimiques, y compris les gaz d'échappement, le monoxyde de carbone, les phthalates et le plomb, identifiés par l'État de Californie comme pouvant causer le cancer et des malformations congénitales ou autres effets nocifs sur la reproduction. Pour limiter toute exposition: évitez de respirer les gaz d'échappement, ne laissez pas tourner le moteur au ralenti sauf si nécessaire, faites l'entretien du véhicule dans une zone bien aérée et portez des gants ou lavez vous fréquemment les mains lors de cette opération.</p> <p>Pour de plus amples informations, consulter  www.P65Warnings.ca.gov/passenger-vehicle</p>
<p>CALIFORNIA</p> <p> Advertencia de la Proposición 65</p> <p>Operar, dar servicio y mantenimiento a un vehículo de pasajeros o vehículo todo terreno puede exponerle a químicos incluyendo gases del escape, monóxido de carbono, ftalatos y plomo, los cuales son conocidos por el Estado de California como causantes de cáncer y defectos de nacimiento u otros daños reproductivos. Para minimizar la exposición, evite respirar los gases del escape, no encienda el motor excepto si es necesario, dé servicio a su vehículo en un área bien ventilada y utilice guantes o lave sus manos frecuentemente cuando dé servicio a su vehículo.</p> <p>Para mayor información visite  www.P65Warnings.ca.gov/passenger-vehicle</p>

G- Other information

For the engine powered machines destined to the US market (Standards ANSI and CSA)

CALIFORNIA



Proposition 65 Warning

Breathing diesel engine exhaust exposes you to chemicals known to the State of California to cause cancer and birth defects or other reproductive harm.

- ✓ Always start and operate the engine in a well-ventilated area.
- ✓ If in an enclosed area, vent the exhaust to the outside.
- ✓ Do not modify or tamper with the exhaust system.
- ✓ Do not idle the engine except as necessary.

For more information go to  www.P65Warnings.ca.gov/diesel

CALIFORNIE



Avertissement de la Proposition 65

Respirer les gaz d'échappement de moteurs diesel peut vous exposer à des agents chimiques identifiés par l'État de Californie comme pouvant causer le cancer et des malformations congénitales ou autres effets nocifs sur la reproduction.

- ✓ Toujours démarrer et faire tourner le moteur dans une zone bien aérée.
- ✓ Si la zone est mal ventilée, évacuer les gaz d'échappement à l'extérieur.
- ✓ Ne pas modifier ou altérer le système d'échappement.
- ✓ Ne laisser le moteur tourner au ralenti que si cela est nécessaire.

Pour de plus amples informations, consulter  www.P65Warnings.ca.gov/diesel

CALIFORNIA



Advertencia de la Proposición 65

Respirar los gases del escape de motores a diésel le expone a químicos conocidos por el Estado de California como causantes de cáncer y defectos de nacimiento u otros daños reproductivos.

- ✓ Siempre encienda y opere el motor en un área bien ventilada.
- ✓ Si es en un área cerrada, ventile el orificio del escape hacia el exterior.
- ✓ Ne pas modifier ou altérer le système d'échappement.
- ✓ No modifique ni altere el sistema de escape.

Para mayor información visite  www.P65Warnings.ca.gov/diesel

H- Intervention register

1 - Intervention register

The intervention register keeps a record of maintenance and repair work carried out inside or outside the maintenance programme.

N.B.-:IN THE CASE OF A HAULOTTE SERVICES® INTERVENTION, THE QUALIFIED TECHNICIAN MUST INDICATE THE HAULOTTE SERVICES® INTERVENTION NUMBER.

Date	Type of intervention	Number of hours	Intervenor	HAULOTTE Services® intervention number

A

B

C

> D

E

F

G

H

I

H- Intervention register

Date	Type of intervention	Number of hours	Intervenor	HAULOTTE Services® intervention number