



**WACKER
NEUSON**

all it takes!

**Operator's Manual
Vibratory plate**

APU



Machine Type	APU3050e
Material Number	5100068122
Version	3
Date	07/2023
Language	[en]

Imprint

Publisher and copyright holder

Wacker Neuson Produktion GmbH & Co. KG
Wackerstraße 6
85084 Reichertshofen, Germany

Registered office: Ingolstadt
Register court and number: Local Court Ingolstadt, HRA3195
DE277138620
Telephone: +49 (0)8453-3403200
Fax:
www.wackerneuson.com

Original operator's manual

This document may be used by the recipient only for the designated purpose. It may in no way be duplicated or translated in any other language, in whole or in part, without prior permission in writing from the manufacturer.

All rights reserved, in particular the copyright, the right of reproduction and the right of distribution applicable worldwide. Reproduction or translation of this publication, in whole or part, is not permitted without the written consent of Wacker Neuson Produktion GmbH & Co. KG.

Violations of legal regulations, in particular of the copyright protection, will be subject to civil and criminal prosecution.

Wacker Neuson Produktion GmbH & Co. KG reserves the right to change its products and their technical specifications for further technical development at any time without any claim to changes to machines already delivered. The information in the technical documentation supplied with the product applies in each case.

The machine on the cover is for illustration purposes only and may therefore have special equipment (options).

Wacker Neuson Produktion GmbH & Co. KG, responsibility for errors or omissions not accepted, printed in Germany.

Copyright © 2023

Contents

1 EC Declaration of Conformity

2 Foreword

2.1 Introduction	7
2.2 Storage Location of the Operator's Manual.....	7
2.3 Accident Prevention Regulations	8
2.4 Contact person	8
2.5 Limitation of liability	9
2.6 Use of the operator's manual	9

3 Usage

3.1 Designated use	10
3.2 Unintended use	10

4 Safety

4.1 Safety symbols and signal words	11
4.2 Principle	11
4.3 Structural changes	12
4.4 Responsibility of the operator.....	12
4.5 Obligations of the operator.....	13
4.6 Qualification of staff.....	13
4.7 General safety instructions.....	13
4.8 Specific vibration plate safety instructions	16
4.9 Safety features	17
4.10 Service	18
4.11 Vehicle fluids	19

5 Description of the Machine

5.1 Type plates and labels	21
5.2 Components	23
5.3 Control elements	23

6 Transportation

6.1 Safety instructions for transport	25
6.2 Prerequisites and preparations	25
6.3 Lifting the machine	25
6.4 Lashing the machine	26
6.5 Transporting the machine to the construction site	27

7 Commissioning

7.1 Safety instructions for operation.....	28
7.2 Tests before commissioning	29
7.3 Install the rechargeable battery	29
7.4 Putting into operation	30

Contents

8 Operation	
8.1 Operating the machine	32
8.2 Selecting the direction of travel	32
8.3 Taking the rechargeable battery out of operation	32
9 Maintenance	
9.1 Safety instructions for maintenance	34
9.2 Maintenance plan	35
9.3 Maintenance work	35
10 Troubleshooting	
10.1 Troubleshooting machine	36
11 Shutdown	
11.1 Temporary decommissioning	37
11.2 Final shutdown	37
12 Accessories	
12.1 Accessories	39
13 Technical Data	
13.1 General instructions	40
13.2 Noise and vibration data	40
13.3 APU	40
13.4 Conversion table	41



**WACKER
NEUSON**

all it takes!

EU Declaration of Conformity

Manufacturer

Wacker Neuson Produktion GmbH & Co. KG, Wackerstraße 6, 85084 Reichertshofen (DE)

This declaration of conformity is issued under the sole responsibility of the manufacturer.

Product	APU3050
Product type	Vibratory plate
Function of product	Soil compaction
Material number	5100060379, 5100063132, 5100072122
Net installed power	3,1 kW
Measured sound power level	107 dB(A)
Guaranteed sound power level	108 dB(A)

Conformity assessment procedure

2000/14/EC, Annex VIII

Notified body

TÜV Rheinland LGA Products GmbH, Tillystr. 2, 90431 Nürnberg (DE) (NB 0197)

Directives and standards

We hereby declare that this product complies with the relevant provisions and requirements of the following directives and standards:

2006/42/EC • 2000/14/EC • 2014/30/EU • EN 500-1:2006 + A1:2009 • EN 500-4:2011

EN ISO 13766-1:2018

Person responsible for technical documents

Wacker Neuson Produktion GmbH & Co. KG, Wackerstraße 6, 85084 Reichertshofen (DE)

Reichertshofen (DE), 05.04.2023

Helmut Bauer

Managing Director



**WACKER
NEUSON**

all it takes!

UK Declaration of Conformity

Manufacturer

Wacker Neuson Produktion GmbH & Co. KG, Wackerstraße 6, 85084 Reichertshofen (DE)

This declaration of conformity is issued under the sole responsibility of the manufacturer.

Product	APU3050
Product type	Vibratory plate
Function of product	Soil compaction
Material number	5100060379, 5100063132, 5100072122
Net installed power	3,1 kW
Measured sound power level	107 dB(A)
Guaranteed sound power level	108 dB(A)

Conformity assessment procedure

SI 2001 No. 1701, Schedule 11

Approved Body

Until 11/2023: TÜV Rheinland LGA Products GmbH, Tillystr. 2, 90431 Nürnberg (DE) (NB 0197)

Starting 12/2023: TUV Rheinland UK Ltd., Friars Gate, 1011 Stratford Road, Shirley, Solihull, B90 4BN (GB) (No. 2571)

Directives and standards

We hereby declare that this product complies with the relevant provisions and requirements of the following directives and standards:

SI 2008 No. 1597 • SI 2001 No. 1701 • SI 2016 No. 1091 • EN 500-1:2006 + A1:2009

EN 500-4:2011 • EN ISO 13766-1:2018

Person responsible for technical documents

Andy Williams (Operations Manager), Wacker Neuson Ltd, WN Place, Beacon Way, Stafford ST18 0DG (GB)

Reichertshofen (DE), 05.04.2023

Helmut Bauer

Managing Director

**UK
CA**

2 Foreword

2.1 Introduction

This operator's manual contains important information and procedures for the safe, proper and economical operation of this machine. Careful reading, understanding and observing it helps to avoid hazards, reduce repair costs and downtimes and thus increase the availability and service life of the machine.

This operator's manual is not a manual for extensive maintenance or repair work. Such work must be carried out by the service partner or by technically trained personnel. The machine must be operated and maintained in accordance with the instructions in this operator's manual. Improper operation or maintenance can cause hazards.

Defective machine parts must be replaced immediately!

The manufacturer is always available to answer questions about operation or maintenance.

2.2 Storage Location of the Operator's Manual

This operator's manual must be kept in the immediate vicinity of the machine and accessible to personnel at all times.

If a second copy of this operator's manual is lost or required, the following options are available for obtaining a replacement:

- On the Internet at <http://www.wackerneuson.com>.
- Contact the service partner

2.2.1 Understanding These Instructions

This section helps to understand the operator's manual and the illustrations used therein.

Target group

People working with this machine must be regularly trained with regard to the dangers and risks occurring when using this machine.



This operator's manual is aimed at:

- Operating personnel:
 - These people have been instructed in working with the machine and about possible dangers and risks arising due to improper behavior.
- Technically trained personnel:
 - These people have a professional training as well as additional knowledge and experience. They are capable of assessing the tasks assigned to them and recognizing any possible risks and dangers.

Explanation of symbols

Symbol	Explanation
1., 2., 3...	Indicates an activity. The sequence of the steps must be observed.
⇒	Indicates a result or an intermediate result of an action.

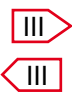

Symbol	Explanation
✓	Indicates prerequisites that must be established for the activity.
•	Indicates a list, e.g. if several components are named one after the other.
-	Indicates a sub-list, e.g. if components consist of further components
	Identifies a position, usually a component or control element, in a graphic. The numbering may be sequential or in Roman numerals.
1; A	Indicates the naming of components in explanatory texts. It is identical with the adjacent positions in the illustrations.
	Indicates a direction of movement or different positions for switches.
	Indicates the avoidance of hazards in warning notices.
[▶52]	Indicates a cross-reference in tables. Here e.g. reference to page 52

2.2.1.1 Explanation of symbols

The symbols used in the operator's manual are explained below. The symbols are used exclusively in warning or environmental instructions or information. Warnings must always be observed to protect the operator and third parties from personal injury and damage to property.



Symbol for warning notices

This symbol marks general warnings. It is used to alert you of possible hazards, e.g. risks of injury or accidents.



Symbol for indications of technical damage

This symbol is a warning symbol that indicates a danger of technical damage. It is used to indicate situations where damage to the machine or third-party property may occur.



Symbol for environmental information

This symbol indicates environmental information. It is used to warn of possible environmental hazards.



Symbol for information

This symbol indicates information. This information can include tips on operation, for example. It helps to better understand and use the machine.

2.3 Accident Prevention Regulations

In addition to the notes and safety instructions in this operator's manual, the local accident prevention regulations and the national industrial safety regulations apply.

2.4 Contact person

Depending on the country, the contact person is a service partner, a subsidiary or a dealer.

- On the Internet at <http://www.wackerneuson.com>.

2.5 Limitation of liability

In the event of the following infringements, the manufacturer disclaims any liability for personal injury and damage to property:

- Actions contrary to this operator's manual.
- Non-designated use
- Deployment of untrained personnel.
- Use non-approved spare parts and accessories.
- Improper handling.
- Structural changes of any kind.
- Non-observance of the General Terms and Conditions (GTC).

2.6 Use of the operator's manual

This operator's manual:

- must be regarded as an integral part of the machine and must be kept in a safe place throughout its service life.
- must be passed on to each subsequent owner or operator of this machine.
- applies to various machine types from one product range. For this reason, some illustrations may differ from the appearance of the purchased machine. Variant-dependent components that are not included in the scope of delivery can also be described.

The manufacturer reserves the right to change the information in this operator's manual without notice.

It must be ensured that any changes or additions made by the manufacturer are immediately incorporated into this operator's manual.



Information

Compatible rechargeable batteries!

The following rechargeable batteries can be used after a software update:

- ▶ BP1000 with production date 10/2022 or later (see type label)
- ▶ BOB14
- ▶ Other non-compatible rechargeable batteries show an error message and do not release any voltage at the connection socket.

Group - Type	Material number (Mat. no.)
Configurable machine*	5100060379
APU3050e	5100063132
APU3050e (Loxam)	5100072122
* In the case of configurable machines, technical data is assigned via the machine's sales designation.	

3 Usage

3.1 Designated use

Designated use also includes observing all notes and safety instructions in this operator's manual and observing the prescribed care and maintenance instructions.

Compaction work in the area:

- Earthwork compaction including:
- Pipeline construction, especially trench application.
- Subsoil for road and path construction.
- Backfilling of structures.
- Asphalt layers in road and path construction.
- Shaking in cobblestones.

Material to be compacted:

- Compaction of mixed and granular soils.
- Non- or weakly cohesive natural soils.
- Gravel mixtures for substructures.
- Gravel-sand mixtures for backfilling.
- Common recycling material for backfill.
- Asphalt layers.
- Plaster (shaking in).

Application area:

- Compaction work on surfaces.
- Compaction work in excavation trenches.
- Operation in enclosed spaces.

Any other use or use that goes beyond this is considered improper use. The manufacturer shall not be liable or liable for any damage resulting therefrom. The risk is borne solely by the operator.

3.2 Unintended use

The manufacturer is not liable for personal injury or damage to property resulting from unintended use. The following activities, among others, are not intended:

- Compaction of strongly cohesive soils.
- Compaction of frozen soils.
- Compaction of hard, non-compactable soils.
- Compaction of non-load-bearing soils.
- Compacting fresh concrete.
- Smashing stones.

4 Safety

4.1 Safety symbols and signal words

The following symbol indicates safety information. It is used to warn of possible personal dangers.



⚠ DANGER

DANGER indicates a situation that leads to death or serious injury if it is not avoided.

Consequences of non-compliance.

- ▶ Preventing injury or death.



⚠ WARNING

WARNING indicates a situation that can lead to death or serious injury if not avoided.

Consequences of non-compliance.

- ▶ Preventing injury or death.



⚠ CAUTION

CAUTION indicates a situation that can lead to injury if not avoided.

Consequences of non-compliance.

- ▶ Preventing injuries.



NOTICE

NOTE indicates a situation that leads to material damage if not observed.

Consequences of non-compliance.

- ▶ Preventing property damage.

4.2 Principle

The machine has been designed and built in accordance with latest state-of-the-art standards and the recognized safety regulations.

Warning! Risk of injury due to improper use.

Improper use can result in danger to life and limb for the operator and third parties or machine and other property damage.

- Read and observe the notes and safety instructions in this operator's manual. Failure to follow these instructions may result in electric shock, fire and/or serious injury, as well as damage to the machine and/or other objects.
- Keep safety instructions and information for the future.

4.3 Structural changes

Warning! Risk of injury due to structural changes.

Unauthorized structural changes to this machine can pose a risk to operators and/or third parties, as well as damage to the machine and/or other property.

- Do not make any structural changes without the manufacturer's written consent.

In particular, a structural change shall be deemed to have occurred:

- When opening of the machine and permanent removal of components.
- Installation of spare parts that do not come from the manufacturer or are not equivalent in design and quality to the original parts.
- Attachment of accessories of any kind that do not originate from the manufacturer.

The manufacturer's liability and warranty are also void in the event of unauthorized structural alterations.

Spare parts or accessories from the manufacturer can be installed or removed safely.

Further information is available on the Internet at - <http://www.wackerneuson.com>.

4.4 Responsibility of the operator

The operator is the person who operates this machine himself for commercial or economic purposes or who leaves it to a third party for use/application and bears the legal product responsibility for the protection of personnel or third parties during operation.

- The operator must make the operator's manual accessible to the personnel at all times and ensure that the operator has read and understood the operator's manual.
- The operator's manual must be kept ready to hand at the machine or at the place of use.
- The operator must hand over the operator's manual to any other operator or subsequent owner of the machine.
- The country-specific regulations, standards and directives on accident prevention and environmental protection must also be observed. The operator's manual must be supplemented by further instructions for compliance with operational, official, national or generally applicable safety guidelines.

4.5 Obligations of the operator

- Know and implement applicable health and safety regulations.
- In a risk assessment, identify hazards arising from working conditions at the place of use.
- Create operating instructions for the operation of this machine.
- Regularly check whether the operating instructions correspond to the current status of the regulations.
- Clearly regulate and define responsibilities for installation, operation, troubleshooting, maintenance and cleaning.
- Train personnel at regular intervals and inform them about possible dangers.
- Refresh instruction at regular intervals.
- Keep records of the training received and make them available to the competent authority on request.
- Provide personnel with the necessary protective equipment.

4.6 Qualification of staff

Warning! Risk of injury due to misuse.

In the event of misuse, abuse or operation by untrained personnel, there is a risk to the health of the operator and/or third parties, as well as damage or total failure of the machine and/or other property damage.

- The machine may only be commissioned and operated by trained personnel.

In addition, the following requirements apply to the operator:

- Physical and mental suitability.
- Minimum age 18 years.
- No influence on reactivity by drugs, alcohol or medication.
- Familiarity with the safety instructions in this operator's manual.
- Familiarity with the intended use of this machine.
- Instructed in the independent operation of the machine.

4.7 General safety instructions

The safety instructions in this chapter contain the "General safety instructions", which must be listed in the operator's manual in accordance with the applicable standards. It may contain instructions which are not relevant for this machine.

4.7.1 Workplace

Warning! Risk of injury due to unsafe work environment.

Unsafe working environment can cause the machine to tip, roll, slide and fall. People can be injured as a result.

- Before starting work, familiarize yourself with the working environment, e.g. load-bearing capacity of the floor or obstacles in the environment.
- Always secure the machine against tipping, rolling, slipping and falling.
- Observe the changing ground conditions, especially on uneven and soft ground or on slopes. Secure the machine against slipping!
- When working near pits, ditches or plateaus, exercise caution! The load-bearing capacity of the ground must safely carry the weight of the machine and the operator.

Warning! Risk of injury if distracted by third parties.

Distraction by others can result in loss of machine control. This can seriously injure people and cause damage to property.

- Secure work area to public transport area.
- Keep unauthorized persons and children away when working with this machine.

Warning! Risk of injury due to adverse working conditions.

Cluttered and poorly lit work areas can lead to accidents. People can trip, fall and be seriously injured as a result.

- Keep work area tidy.
- Provide adequate lighting.

4.7.2 Personal safety

Warning! Risk of injury due to physical impairment.

Physical impairment can reduce the ability to react. This can lead to loss of machine control. People can be injured as a result.

- Do not work under the influence of drugs, alcohol or medication.

Warning! Danger of being drawn in by unsuitable clothing and long hair.

Wide or loose clothing, protective gloves, jewelry and long hair can be caught and pulled in by moving/rotating machine parts. This can result in severe injuries.

- Keep loose or loose clothing and protective gloves away from moving/rotating machine parts.
- Remove jewelry before starting work.
- Tie up long hair or use a hair net.

Warning! Danger of falling due to unsafe position.

Working in an unstable position can lead to falls. Falls can cause serious injuries.

- Always ensure a safe footing.
- Always have both feet on the ground.

Warning! Risk of injury to third parties

Bystanders can be seriously injured by incidents in the work area.

- Make sure there are no other people in the danger area.

Caution! Damage to health from exposure to vibration.

Prolonged use of this machine may result in long-term vibration-related damage or impaired circulation in the fingers, hands or wrists. Signs of this can be body parts falling asleep, tingling, hurting, stinging and discoloring.

In the case of personal predisposition to poor blood circulation, working time can be reduced despite safety gloves and regular breaks from work.

- Take regular breaks from work.
- If these symptoms are detected, consult a doctor immediately.
- Observe national occupational safety requirements.

Vibration exposure, [see Technical Data on page 40](#)

Personal protective equipment

Suitable protective equipment must be used for all work. Personal protective equipment considerably reduces the risk of injury.

Warning! Risk of hearing damage from exceeding permissible noise limits.

Working with the machine without hearing protection can lead to hearing damage in the long-term.

- Always use hearing protection when working with the machine.
- When working with hearing protection, work particularly attentively and carefully, because noises, e.g. screams or beeps, are only perceived to a limited extent.

4.7.3 Handling and use

Warning! Risk of injury from falling loads.

In the event of improper transport or transport with unsuitable lifting gear, loads can fall. People can be hit and seriously injured or killed.

- Do not stay under lifted loads.
- Only use suitable and tested lifting gear and slings with sufficient load-bearing capacity.
- Secure the machine safely to the lifting gear.
- Use appropriate transport method.

Warning! Risk of crushing from swinging loads.

Improper transport can cause loads to swing. People can be hit or crushed by this and be seriously injured or killed.

- Keep a sufficient distance from the lifted loads.
- Secure raised loads against swinging.

Warning! Danger to life due to unauthorized troubleshooting

Unauthorized troubleshooting can lead to unforeseen machine states. People can be injured as a result.

- If faults occur on this machine which are not described in this operator's manual, contact the service partner.
- Do not rectify faults on your own.

Warning! Risk of injury from defective machines or components.

Defective machines or components can lead to unforeseen machine states. People can be injured as a result.

- Handle machines with care.
- Do not start a defective engine.
- Have defective parts replaced before operating the machine.

Warning! Risk of injury due to functionally restricted controls.

Controls that are not fully functional can lead to unforeseen machine states. People can be injured as a result.

- Check the machine's controls for functionality before operation.
- Do not lock, manipulate or alter the machine controls in an inadmissible manner.

Warning! Risk of injury due to unauthorized start-up.

Unauthorized start-up can lead to dangerous situations. Persons involved can be seriously injured as a result.

- Only allow the machine to be operated by authorized personnel.
- Secure unused machines against unauthorized putting into operation.
- After operation, store the machine in a locked, clean, frost-free and dry place that is inaccessible to other people and children.
- Use the machine, accessories, tools etc. in accordance with these instructions.

4.8 Specific vibration plate safety instructions

4.8.1 External influences

Caution! Risk of injury from slipping machine.

In heavy rain, the machine may slip on sloping surfaces. This can injure people and damage the machine.

- Do not operate the machine on inclined surfaces in heavy rain.

4.8.2 Operational safety

Warning! Risk of injury from uncontrolled guided machine.

Loss of machine control can result in serious injury to the operator or others.

- Always hold the machine with both hands.
- Take a firm stand.

Warning! Risk of injury from tipping or slipping machine.

The machine can tip over or slide off in the vicinity of escarpments. People can be hit and seriously injured.

Make sure at least 2/3 of the machine is on a stable surface.

Otherwise, take the machine out of operation and move it to a stable surface.

Caution! Risk of injury from the machine slipping.

When operating the machine on inclined surfaces, the machine can slip and tip over. This can injure people and damage the machine.

- Only approach gradients from below.
- Stay above the machine during compaction work across the slope.
- Do not leave the designated operating position when the machine is in operation.
- Exercise the utmost degree of caution near abysses or slopes.
- Ensure stability.

Caution! Danger of being buried in ditches and pits.

When operating the machine in ditches and pits, side walls can collapse due to vibration. People can be buried and injured.

- Check side walls for stability before starting work.
- Pay close attention to sidewalls in ditches and pits.

Caution! Risk of injury to third parties when the machine is running.

When operating the machine, people in the work area can be injured.

- Never let the machine run unattended.
- Block off a large work area and keep unauthorized persons away.
- Make sure people in the work area keep a minimum distance of 2 meters from the running machine.

4.8.2.1 Safety distances

Note! Material damage due to careless work.

Careless work can damage lines laid in the floor.

- When operating the machine, make sure that no gas, water or electrical lines or pipes are damaged.

Note! Material damage caused by vibrations.

Compaction work in the vicinity of buildings can lead to building damage.

- Check all possible effects and vibrations on surrounding buildings beforehand.
- Observe the relevant regulations and rules for measuring, assessing and reducing vibrations, in particular DIN 4150-3.

Information! The manufacturer shall not be liable for any damage to buildings.

4.9 Safety features

Safety features protect the operator of this machine from being exposed to the existing hazards. These are barriers (separating protective devices) or other technical measures that serve to avert or reduce hazards.

Warning! Risk of injury due to modified or removed safety devices.

Modified or removed safety devices lose their protective function. People can be injured as a result.

- Operate the machine only when the safety devices are correctly installed and functional.
- Do not change or remove safety devices.
- Reattach safety and protective devices removed for maintenance/service (e.g. V-belt protection).



The V-belt guard 1 protects the operator against crushing and entrapment.

4.10 Service

Warning! Risk of injury from defective machine.

Machines that are not or improperly maintained/repared may have defects that go unnoticed. This can cause personal injury and property damage.

- Observe maintenance intervals according to maintenance plan.
- Only have the machine repaired or serviced by technically trained personnel.
- Have work not listed in the maintenance plan carried out by the service partner.
- Replace worn or damaged machine parts immediately.
- Only use original spare parts and accessories. The operational safety of the machine is thus maintained.
- Carry out maintenance work in a clean and dry environment (e.g. workshop).
- Replace any missing, damaged or illegible safety labels immediately. Safety and information labels contain important information for the protection of the operator.
- Keep the machine clean.

Warning! Risk of injury due to modified or removed safety devices.

Modified or removed safety devices lose their protective function. People can be injured as a result.

- Operate the machine only when the safety devices are correctly installed and functional.
- Do not change or remove safety devices.
- Reattach safety and protective devices removed for maintenance/service (e.g. V-belt protection).

Caution! Risk of crushing/risk of burns when the machine is running.

Moving/rotating machine parts can cause crushing. Hot machine parts can cause burns if touched.

- Do not service, repair, adjust or clean the machine when it is switched on.
- Switch off the machine and let it cool down.

Caution! Risk of crushing if the machine starts up unintentionally.

Machines with an external or internal power supply can start up unintentionally. People can be injured by moving parts.

- Remove accumulator from the machine before maintenance work.

4.10.1 Threaded fittings

Caution! Risk of injury due to missing or loose screw connections.

Missing or loose screw connections can lead to loose machine parts. People can be injured as a result.

- All threaded fittings must comply with the specified specifications and be firmly bolted together.
- Observe the correct tightening torques.
- Screws and nuts must not be damaged, bent or deformed.
- Particular attention should be paid to the following:
 - Self-locking nuts and micro-encapsulated screws must not be reused after loosening. The fastening effect is lost.
 - Screw connections with adhesive securing/liquid adhesives (e.g. Loctite) must be cleaned after loosening and provided with new adhesive before reuse.

Information! Observe the instructions of the liquid adhesive manufacturer.

4.11 Vehicle fluids

Warning! Danger of scalding from hot operating materials.

Operating materials can become very hot after a short operation period. Contact with hot operating materials can lead to severe scalding.

- Switch off the machine and let it cool down.
- Use protective gloves.

Warning! Risk of fire and explosion from flammable cleaning agents.

Flammable detergents can cause fires and explosions. People can be injured as a result.

- Do not clean the machine and components with gasoline or other solvents.

Environment Risk of environmental damage.

Operating materials that get into the ground, water bodies or sewage system can cause environmental damage.

- Line work surface with impermeable foil.
- Use collection containers for old operating materials.
- Dispose of discharged or spilled vehicle fuel in accordance with applicable environmental regulations.
- Clean the machine in a suitable place where the dirty waste water can be collected in an environmentally friendly manner.
- Collect contaminated water and dispose of it in an environmentally friendly manner.

5 Description of the Machine

5.1 Type plates and labels

5.1.1 Type label

A type label is permanently attached to the machine.

Other type labels

Furthermore, the following components of the machine are provided with their own type label:

- the rechargeable battery

Symbols on the type label

Various symbols and markings for national and international approvals can be shown on or next to the nameplate.

5.1.1.1 Labeling on the machine

Type label data

The type label contains information that uniquely identifies this machine. This information is required for ordering spare parts and for technical queries.

Enter the data on the machine in the following table:

Designation	Your details
Group - Type	
Material number (Mat. no.)	
Machine version (version)	
Machine number (machine no.)	
Year of construction	

5.1.2 Safety and information labels



⚠ WARNING

Injury hazard due to missing or damaged labels and signs!

Safety labels contain important information to protect the operator.

- ▶ Keep all safety, warning and operating instructions on the machine in a clearly legible condition.
- ▶ Replace missing or damaged labels and signs immediately.

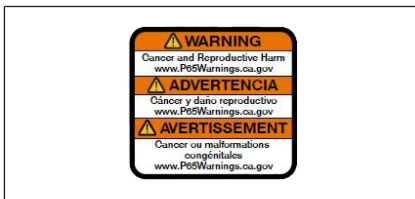

Warning of health risks

WARNING! CALIFORNIA: Proposition 65 (Safe Drinking Water and Toxic Enforcement Act of 1986)

For more information: www.P65Warnings.ca.gov



No lifting point.

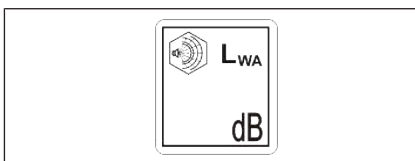

Guaranteed sound power level.



Caution: Risk of injury

- Risk of burns due to hot surface!
- Keep back.

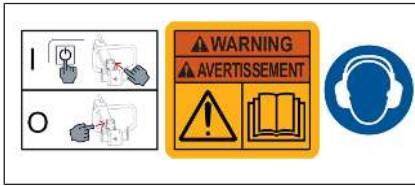

Start Stop quick guide.
Read the operator's manual.
Use hearing protection.



The falling machine can cause serious injuries.

- Only lift the machine at the central suspension with tested lifting gear and slinging gear (safety load hook).
- Do not lift the machine with an excavator bucket or forklift truck on the central suspension.



Type label.

5.2 Components

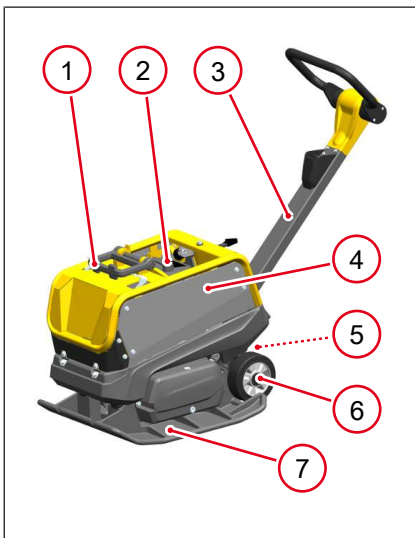

- | | |
|---|---|
| 1 | Central suspension |
| 2 | Rechargeable battery |
| 3 | Drawbar |
| 4 | Protective frame / guide rechargeable battery |
| 5 | Step |
| 6 | Wheel set |
| 7 | Base plate |

5.3 Control elements

Always keep the displays and controls of the machine dry, clean and free of oil and grease.

Do not lock, manipulate or alter the machine operating elements in an inadmissible manner.

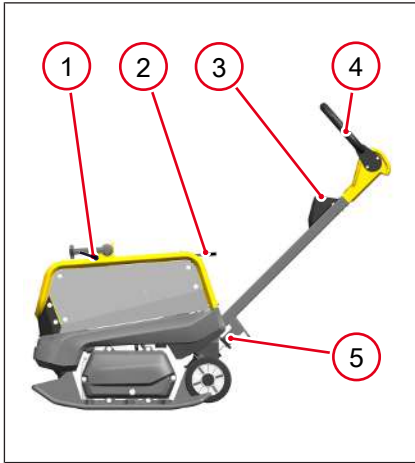

- | | |
|---|---------------------------|
| 1 | Lock rechargeable battery |
| 2 | Drawbar lock |
| 3 | Switch On/Off |
| 4 | Gear lever |
| 5 | Drawbar height adjustment |

6 Transportation

6.1 Safety instructions for transport



⚠ WARNING

Hazard of falling!

The falling machine can cause serious injuries, e.g. by crushing.

- ▶ Only use suitable and tested lifting gear and slings (safety hooks) with sufficient lifting capacity.
- ▶ Only lift the machine by the central suspension.
- ▶ Secure the machine safely to the lifting gear.
- ▶ Do not lift the machine by the drawbar.
- ▶ Leave the danger zone when lifting, do not stand under suspended loads.

6.2 Prerequisites and preparations

- Switch off the machine and let it cool down.
- We recommend removing the rechargeable battery from the machine before charging and transporting.
- Use only suitable hoists with sufficient lifting capacity.
- Only use suitable lifting equipment with sufficient lifting capacity, [see Technical Data on page 40](#).
- The transport vehicle must have a sufficient bearing load and a suitable loading surface.

6.3 Lifting the machine

Lifting with lifting device and lifting gear



⚠ WARNING

Risk of crushing!

If the machine is unstable, the lifting gear and the hoist may fail and fall down.

- ▶ Check the stability of the lifted machine before continuing work.



⚠ CAUTION

Danger of burns due to hot surfaces!

Exciter can become very hot after a short time, which can cause severe burns if it comes into contact with the skin.

- ▶ Always allow the machine to cool down after use.
- ▶ If the cooling phase cannot be maintained (e.g. due to an emergency) - use heat-resistant protective gloves.

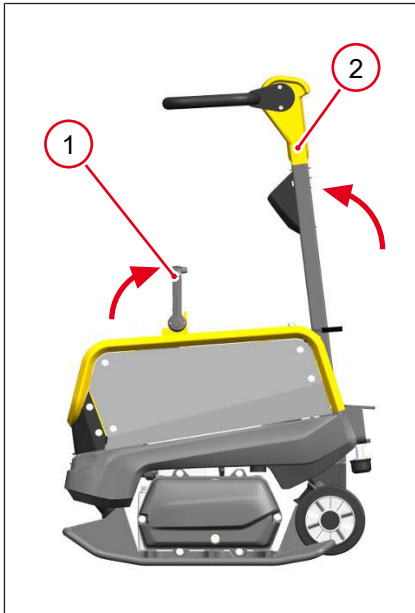

1. To ensure safe lifting, appoint a competent instructor.
2. Only use certified lifting and fastening gear.
3. Attach suitable sling to central suspension **1**.
4. Load the machine into or onto the transport vehicle.
5. Lock drawbar **2**.

6.4 Lashing the machine



NOTICE

Use anti-slip mats to secure the load.

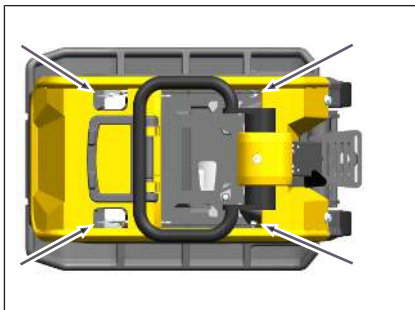

Only use the lashing points provided for this purpose to secure the machine.

- Tie down the machine as shown.
- ⇒ The machine is secured against unrolling, slipping and tipping over.

6.5 Transporting the machine to the construction site



- ✓ Drawbar is positioned vertically and locked.
- 1. Hold the machine by the switch bracket **1**.
- 2. Step onto step **2** with one foot and tilt towards the operator.
- 3. Pull or push the machine to move it.

7 Commissioning

7.1 Safety instructions for operation



⚠ WARNING

Risk of serious injury, death and property damage due to smoke development and fire!

A damaged or defective rechargeable battery can smell unusual, smoke or burn. Persons may be seriously injured or killed and property damage may occur.

- ▶ Do not use the rechargeable battery and separate it from combustible materials if it smells or smokes unusually.
- ▶ In case of fire, extinguish with water only, do not use a direct water jet.



⚠ WARNING

Tipping hazard due to slipping or overturning machine!

At least 2/3 of the machine must be on a stable surface near edges.

- ▶ Take the machine out of operation and lift it back onto a stable surface.



⚠ WARNING

Improper handling may result in injury or serious material damage.

- ▶ Please read and follow all safety instructions in this operator's manual.



⚠ WARNING

Risk of hearing damage if the country-specific noise limit is exceeded!

Working with the machine without hearing protection can lead to hearing damage in the long-term.

- ▶ Wear ear protectors.
- ▶ Work attentively and cautiously when using hearing protection.



⚠ CAUTION

Health hazard due to vibrations!

Physical impairments due to vibration.

- ▶ Take regular breaks.



⚠ CAUTION

Risk of collapse and spillage!

There is a risk of injury from falling or spilling when working on fracture, pit, dump and embankment edges, on trench edges and heels.

- ▶ Pay attention to side walls and their stability.
- ▶ Ensure stability.

Operation on inclined surfaces

- Only approach gradients from below.

Ground conditions

The maximum dumping height depends on several factors of the ground conditions. An exact specification of this value is not possible.

- Determine the maximum fill height by compaction tests or soil samples.

Shaking in cobblestones

- To avoid damage to the machine or compaction material, use a sliding device, [see Accessories on page 39](#).

7.2 Tests before commissioning



Information

Further information and detailed descriptions, [see Maintenance on page 34](#).

Perform the following checks:

- Check machine and components for damage.
 - Do not put the damaged machine into operation. Damages and defects must be repaired immediately.
- Check the charge state of the accumulator.
- Check to ensure the screw connections are firmly seated.
- Check control elements for functionality.

7.3 Install the rechargeable battery



NOTICE

Damage to the machine or the accumulator.

Connections and contact area of the accumulator must be clean and dry.



NOTICE

Note on putting into operation!

Detailed and illustrated information can be found in the operator's manual of the machine.

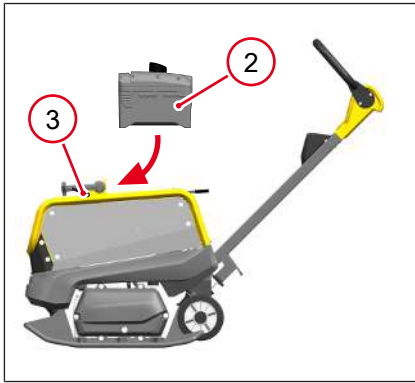

1. Place rechargeable battery **2** on the charger.
 2. Carefully insert the rechargeable battery into the provide guide rail.
 3. Insert the rechargeable battery by the handle until you hear a clearly audible snapping sound of the lock **3**.
 4. Make sure the accumulator is firmly seated.
- ⇒ The machine is ready for operation.

7.4 Putting into operation



NOTICE

Active fan control for cooling the rechargeable battery and converter

- ▶ The fan can start running as soon as the rechargeable battery is switched on.
- ▶ The fan can continue to run after the machine has been switched off if the rechargeable battery is activated.



NOTICE

Possible error message on the rechargeable battery

If the machine is started too quickly, error messages may appear on the accumulator.

- ▶ Wait at least 4 seconds after activating the rechargeable battery.
- ▶ Then continue with the starting procedure.



1. Hold the machine by the switch bracket.
2. Press start button **1**.
⇒ Rechargeable battery is activated.
3. Check the charge level of the rechargeable battery **2**.
4. Wait at least 4 seconds, then start the machine.

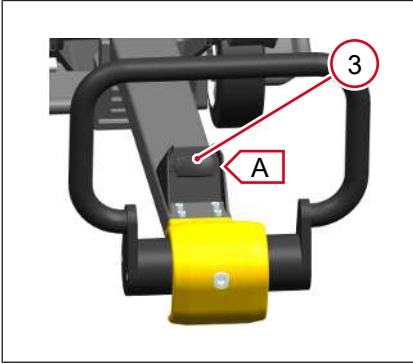

- Set switch **3** to position **A**.
 - ⇒ The machine starts up.
- ⇒ Vibration begins when moved forward.

8 Operation

8.1 Operating the machine

The operator's designated location is behind the machine.
Guide and steer the machine using the switch bracket.

8.2 Selecting the direction of travel



Information

When the drive lever is released, the selected direction of travel is canceled and the lever automatically moves to position A.

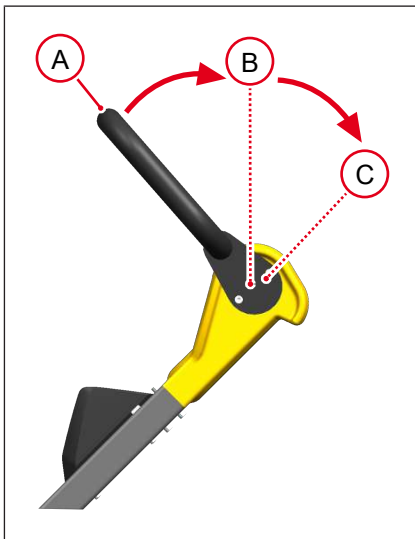

Position A: Direction of travel forward, neutral position of the drive lever.

Position B: Standing vibration.

Position C: Reverse direction of travel.

8.3 Taking the rechargeable battery out of operation

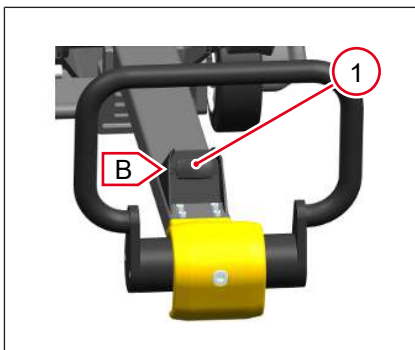

Taking the machine and rechargeable battery out of operation

✓ The machine is on a level surface.

1. Set switch 1 to position B.
 - ⇒ Machine switches off.
 - ⇒ Rechargeable battery stays active for 5 minutes to restart machine.
2. Deactivate the rechargeable battery at the start button.
 - ⇒ Rechargeable battery is deactivated.
3. Allow the machine to come to a complete stop.
 - ⇒ The machine is out of operation.



Remove the rechargeable battery

✓ The machine is out of operation.

1. Pull lock **3** to the rear.

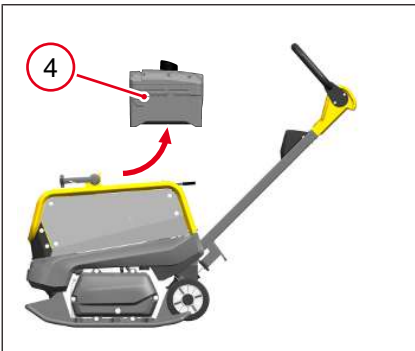

2. Carefully pull back rechargeable battery **4** by the handle as far as it will go.

3. Pull out the rechargeable battery by the handle and put it down safely.

9 Maintenance

9.1 Safety instructions for maintenance



⚠ WARNING

Improper handling may result in injury or serious material damage.

- ▶ Please read and follow all safety instructions in this operator's manual.



⚠ WARNING

Risk of injury from uncontrolled machine starting and moving parts!

- ▶ Only perform maintenance work when the machine is switched off.
- ▶ Remove the rechargeable battery.



⚠ CAUTION

Danger of burns due to hot surfaces!

Exciter can become very hot after a short time, which can cause severe burns if it comes into contact with the skin.

- ▶ Always allow the machine to cool down after use.
- ▶ If the cooling phase cannot be maintained (e.g. due to an emergency) - use heat-resistant protective gloves.



NOTICE

Damage by penetrating water!

Penetrating water can damage electrical operating elements or machine components.

Penetrating moisture can lead to total failure.

- ▶ Do not clean the machine with high pressure or steam cleaners!
- ▶ Use a cloth to remove water that has entered (e.g. due to rain) the housing and then let the machine dry.
- ▶ Only use dry and clean cloths.



Environment

Avoid damage to the environment!

- ▶ Clean the machine in a suitable place where the dirty waste water can be collected in an environmentally friendly manner.
- ▶ Collect contaminated water and dispose of it in an environmentally friendly manner.

9.2 Maintenance plan

Maintenance work	daily	125 h
Clean the machine. <ul style="list-style-type: none"> • Visual check for completeness. • Visual check for damage. 	•	
Check operating elements for ease of movement.	•	
Check screw connections.	•	
Check rubber buffer.		•

9.3 Maintenance work

Carrying out preparations:

1. Place the machine on a level surface.
2. Decommissioning the machine.
3. Let the machine cool down.
4. Remove the rechargeable battery.

9.3.1 Cleaning the machine



NOTICE

Notice for cleaning the machine!

- ▶ Do not clean the machine with high pressure or steam cleaners!

Observe the following when cleaning:

- Clean machine with compressed air.

Visual check after cleaning:

1. Check cables, hoses and lines for leaks and chafe marks.
2. Check screw connections.
 - ⇒ Replace damaged components.
3. Check all safety, warning and operating instructions for completeness.
 - ⇒ Replace missing or damaged labels and signs immediately.

10 Troubleshooting

10.1 Troubleshooting machine



⚠ WARNING

Danger to life due to unauthorized troubleshooting!

- ▶ If faults occur on this machine which are not described in this operator's manual, contact the service partner.
- ▶ Do not rectify faults on your own.



NOTICE

Possible error message on the rechargeable battery

If the machine is started too quickly, error messages may appear on the accumulator.

- ▶ Wait at least 4 seconds after activating the rechargeable battery.
- ▶ Then continue with the starting procedure.

Fault	Possible cause	Remedy
The machine will not operate.	On/Off switch is not off.	Move the switch to position 0.
	Rechargeable battery is not activated.	Activate rechargeable battery.
	The charge condition of the rechargeable battery is too low.	Charge the rechargeable battery.
	The rechargeable battery is not inserted correctly into the machine.	Insert the rechargeable battery correctly into the machine.
	The rechargeable battery is defective.	Have the rechargeable battery repaired.*
The machine is displaying unexpected faults when putting into operation or operation.	Troubleshooting Observe rechargeable battery.	Deactivate the rechargeable battery and remove it from the machine. If the fault persists, have the rechargeable battery repaired.*
The machine switches itself off.	The charge condition of the rechargeable battery is too low.	Charge the rechargeable battery.
	The machine was overloaded.	Switch the machine on again.
	Machine is overheated.	Let the machine cool down.
	Machine under temperature.	Operate the machine only within the permissible temperature range, Technical Data.

* Have this work carried out by a service partner.

11 Shutdown

11.1 Temporary decommissioning



⚠ WARNING

Fire and explosion hazard!

Storage with other hazardous substances may lead to fire or explosion due to dangerous interaction.

- ▶ Store separately from other hazardous materials.
- ▶ Store away from other flammable materials.
- ▶ Keep a minimum distance of 2.5 m.



Information

Further information and detailed descriptions, [see Maintenance on page 34](#).

Storage requirements

- Store dust-free and dry.
- Do not store outdoors.
- Protect from direct sunlight.
- Observe storage temperature, [see Technical Data on page 40](#).
- Store in a locked place that is not accessible to children.

If the machine is stationary for more than 1 month, perform the following measures:

Entire machine	<ul style="list-style-type: none"> • Clean thoroughly. • If necessary, rectify all defects. • Check for leaks, rectify any defects if necessary.
----------------	---

If the machine is shut down for more than 6 months, contact a service partner.

11.2 Final shutdown

If the machine is no longer in use and is shut down for good, all operating fluids must be drained.

Have the machine professionally dismantled and disposed of by a state-approved recycling company.

Professional disposal of this machine avoids negative effects on human health and the environment, helps with the targeted treatment of pollutants and makes it possible to recycle valuable raw materials.

11.2.1 Disposal of old electrical and electronic equipment

Disposal of old electrical and electronic equipment

Professional disposal of this machine avoids negative effects on human health and the environment, helps with the targeted treatment of pollutants and makes it possible to recycle valuable raw materials.

For customers in EU countries

This machine is subject to the European directive for old electrical and electronic equipment (Waste Electrical and Electronic Equipment (WEEE)), as well as the corresponding national laws.

The WEEE directive provides the framework for an EU-wide treatment of old electrical equipment.

The machine is marked with the crossed-out garbage bin symbol. This means that you do not dispose of the battery in normal household waste but that it must be disposed of in a separate, environmentally friendly collection facility.

This unit is intended as a professional electrical tool exclusively for commercial use (so-called B2B device according to WEEE directive). In contrast to equipment mainly used in private households (so-called B2C equipment), this machine may therefore not be disposed of in some EU countries, e.g. in Germany, at the collection points of the public waste disposal authorities (e.g. municipal recycling centers). In case of doubt, information on the prescribed disposal route for B2B electrical appliances in the respective country can be obtained from the sales outlet in order to ensure disposal in accordance with the applicable legal regulations. There are also some notes to follow in the sales contract or in the general Terms and Conditions of the sales location.

For customers in other countries

It is recommended that you do not dispose of the machine in normal household waste but rather in a separate, environmentally friendly collection facility. National laws also may, under certain circumstances, prescribe the separate disposal of electrical and electronic products. Correct disposal of this machine in accordance with current national guidelines must be assured.

12 Accessories

12.1 Accessories



⚠ CAUTION

Risk of injury and possible machine damage!

Use of non-original spare parts or accessories can lead to injuries or machine damage.

- ▶ Only use original spare parts and accessories.
- ▶ In case of disregard, no liability will be accepted.

Slide mechanism

Surface protection, [see Safety instructions for operation on page 29](#)

13 Technical Data

13.1 General instructions



Information

For system technical reasons, empty columns can be displayed in the technical data, and numbers and letters that written in superscript or subscript may be displayed incorrectly, e.g:

- ▶ Sound power level LWA instead of L_{WA}
- ▶ Sound pressure level LpA instead of L_{pA}
- ▶ Vibration total value ahv instead of a_{hv}
- ▶ Carbon dioxide CO2 instead of CO_2
- ▶ Unit m/s2 instead of m/s^2

13.2 Noise and vibration data

The noise and vibration data listed have been determined in accordance with the following guidelines for the typical machine operating conditions / special test conditions and using harmonized standards:

- Machinery Directive 2006/42/EC
- Noise Emission Directive 2000/14/EC

During operational use, values may differ depending on the prevailing operating conditions.

Sound pressure level at operator station

- L_{pA} was determined according to EN ISO 11201 and EN 500-4.

Guaranteed sound power level

- L_{WA} was determined according to EN ISO 3744 and EN 500-4.

Weighted vibration total value hand-arm vibration

- a_{hv} was determined according to EN ISO 20643 and EN 500-4.

13.3 APU

Type	APU3050e	APU3050e (Loxam)
Material number machine	5100063132	5100072122
Centrifugal force [kN]	30	30
Vibrations [Hz]	90	90
Vibrations [1/min]	5400	5400
Area output* [m ² /h]	570	570
Flow [m/min]	19	19
Gradeability [%]	48	48
Nominal power** [kW]	3.1	3.1
Rated current [A]	61	61
Rated voltage [V]	51	51

Type	APU3050e	APU3050e (Loxam)
Material number machine	5100063132	5100072122
Protection type	IP23D	IP23D
Type of current (output)	DC	DC
Length (drawbar in working position) [mm]	1320	1320
Width [mm]	500	500
Height [mm]	1188	1188
Underclearance [mm]	618	618
Operating weight [kg]	212	212
Operating temperature range [°C]	0 - +40	0 - +40
Storage temperature range [°C]	-30 - +50	-30 - +50
Sound pressure level at operator station LpA [dB(A)]	93	93
Sound power level LWA, measured [dB(A)*]	107	107
Sound power level LWA guaranteed [dB(A)]	108	108
Vibration total value ahv [m/s ²]	< 2,5	< 2,5
Measurement uncertainty of the total vibration value ahv [m/s ²]	0,5	0,5
Recommended rechargeable battery type	BOB10, BOB14	BOB10, BOB14
Rechargeable battery life [min]	25, 35	25, 35
* Depending on the soil conditions.		
** Corresponds to the installed net power according to Directive 2000/14/EC.		

13.4 Conversion table

The following conversion tables enable the conversion of the metric values from the instructions, in particular the technical data, into the imperial.

Conversion table	
Volume units	
1 cm ³	0.061 in ³
1 m ³	35.31 ft ³
1 ml	0.034 US fl.oz.
1 l	0.26 gal.
1 l/min	0.26 gal./min
Length units	
1 mm	0.039 in
1 m	3.28 ft
Weights	
1 kg	2.2 lbs.
1 g	0.035 oz.
Pressure	
1 bar	14.5 psi
1 kg/cm ²	14.22 lbs/in ²
Force/output	
1 kN	224.81 lbf

Conversion table	
1 kW	1.34 hp
1 PS	0.986 hp
Torque	
1 Nm	0.74 ft.lbs
Speed	
1 km/h	0.62 mph
Acceleration	
1 m/s ²	3.28 ft./s ²



**WACKER
NEUSON**
all it takes!

**Wacker Neuson Produktion GmbH &
Co. KG**
Wackerstraße 6
D-85084 Reichertshofen

Tel.: +49 8453 340-0
Email: service-LE@wackerneuson.com
www.wackerneuson.com

Material Number: 5100068122
Language: [en]