

Data sheet HS3.75SL-52

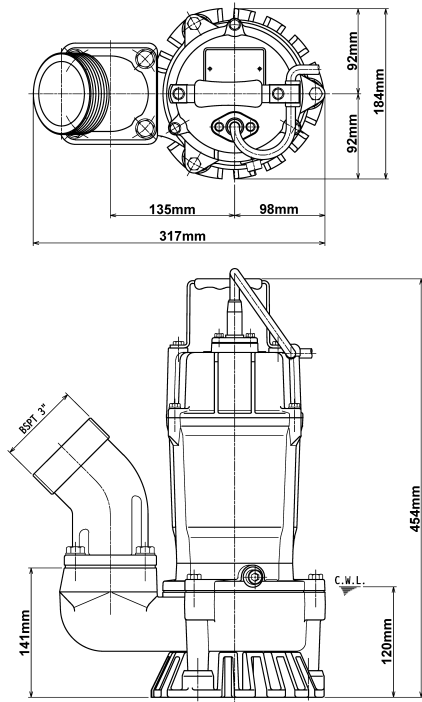

CWL: Continuous running water level

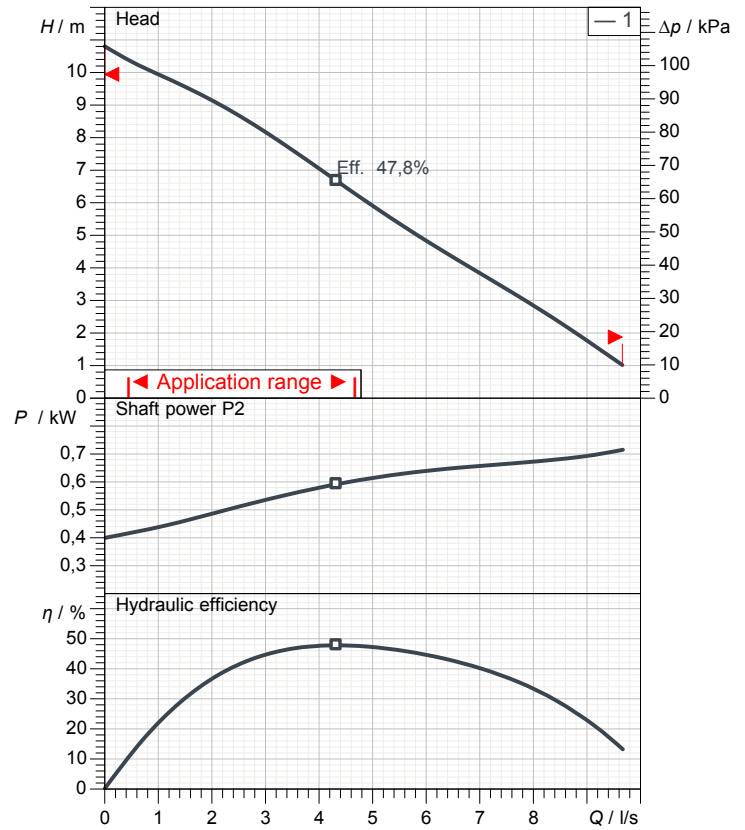

Specification

Electric submersible pump HS-series
 Degree of protection IP 68
 Pressure resistance max. 10 m
 Type of impeller semi-vortex
 Max. solid handling 7 mm
 Suitable for:
 rain water, ground water, sand water

Electric motor

Dry-type submersible induction motor
 Insulation class E 2Poles 2830 1/min
 Starting mode
 Rated voltage 230 V 50 Hz 1~
 Power uptake 1,06 kW
 Rated power 0,75 kW
 Rated current 4,8 A
 Start current 14,6 A

Cable

10m H07RN8-F 3Cx1mm²

Motor Protection

Miniature protector in windings
 (snap-action bi-metal device)

Shaft seal

Double inside mechanical seal in oil bath
 additional lubrication by oil lifting device
 Primary seal
 Silicon carbide on silicon carbide
 Secondary seal
 Carbon on ceramic

Bearings

Shielded ball bearings, maintenance-free

Materials

Impeller	Urethane rubber
Pump casing	FCD700 (EN-GJS-700-2)
Motor Frame	Aluminium die casting
Shaft	SUS403 (EN-X6Cr13)

Discharge size

3" (80mm) BS-Coupling / Hose Coupling (optional)

Weight

19,6 kg (dry weight of the pump only without cable)

Performance curve

HS3.75SL-52

Discharge port	3"
Head	10,8 m
Flow	9,7 l/s
Rated power	0,75 kW
Power input	1,06 kW
Phases	1~
Voltages	230 V
Frequency	50 Hz
Rated current	4,8 A
Starting current	14,60 A
Number of poles	2
Speed	2830 1/min
Starting mode	
Insulation class	E

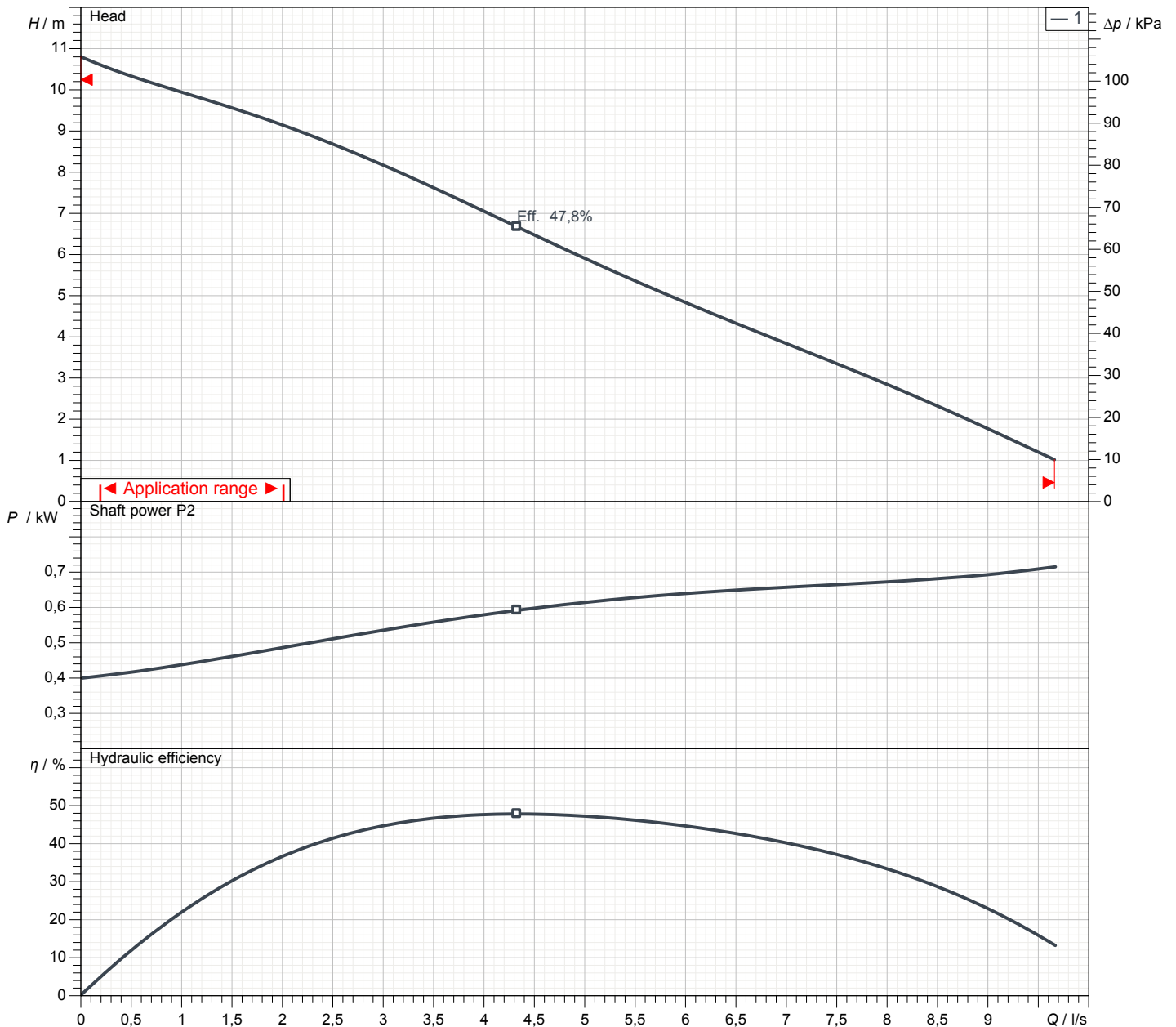

Dimensions

HS3.75SL-52

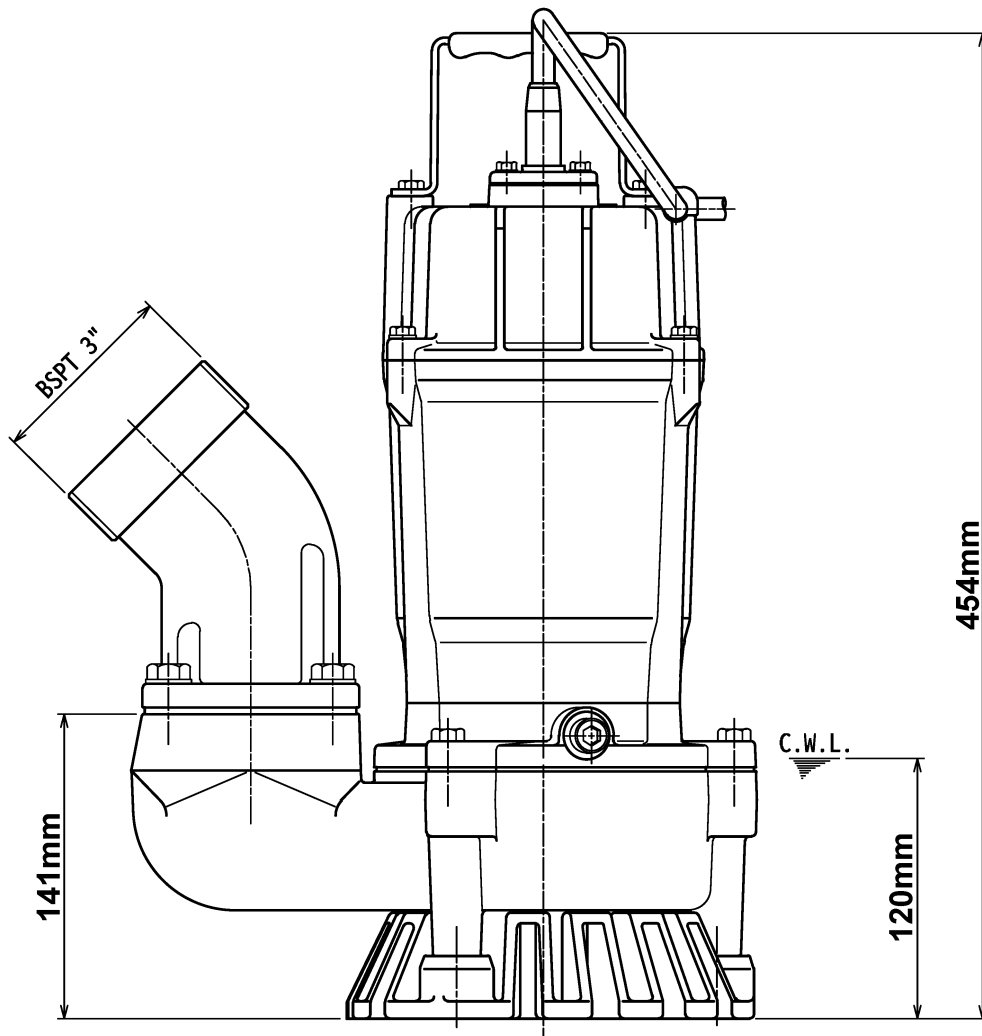
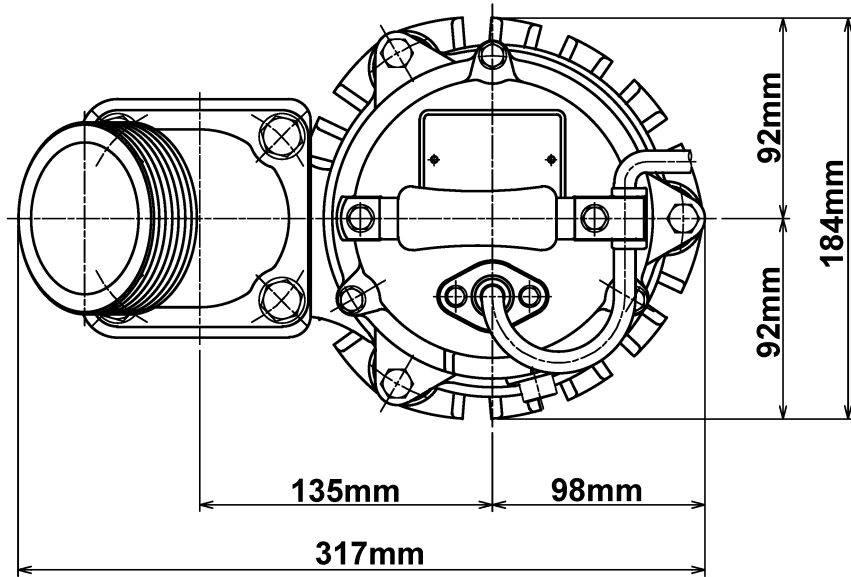

HS3.75SL-52

CWL: Continuous running water level
LWL: Lowest running water level

Sectional drawing HS3.75SL-52

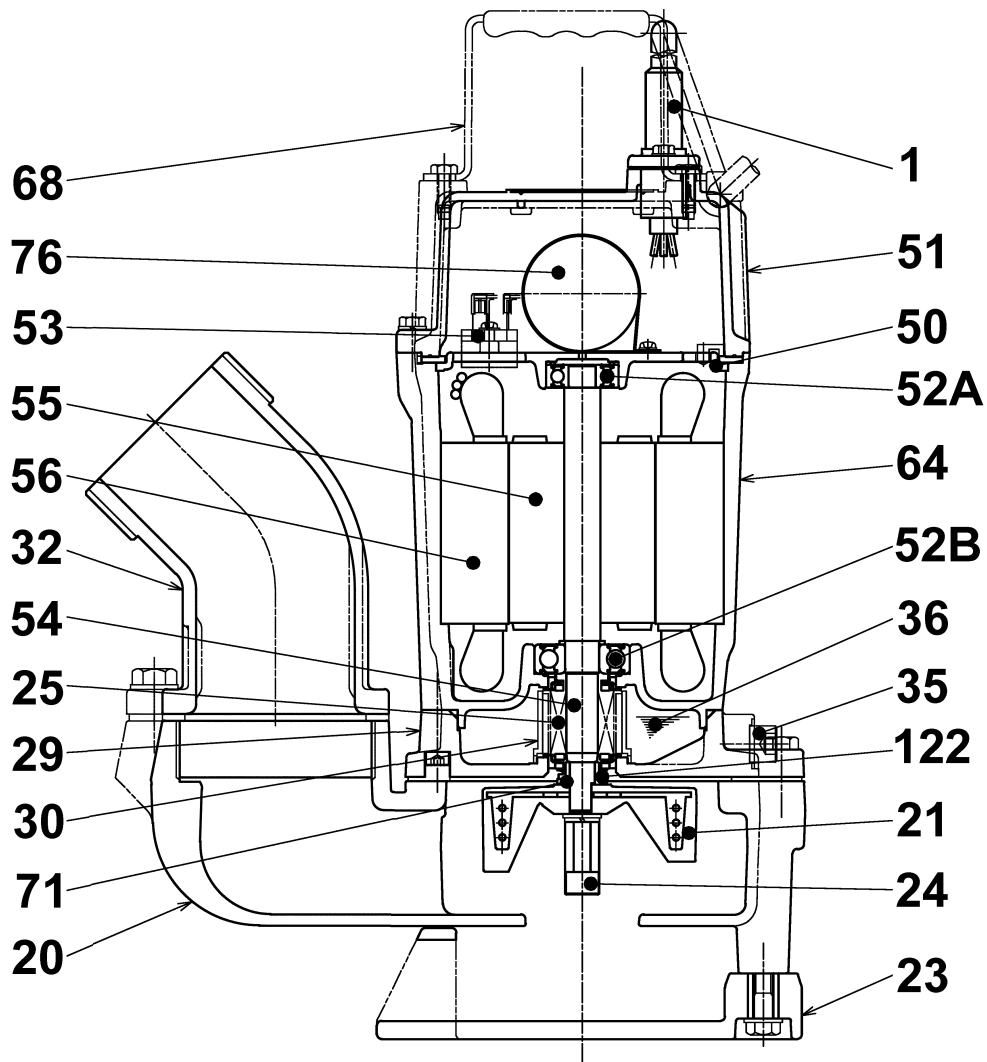

HS3.75SL-52

No.	Description	Remark	No.	Description	Remark
1	Cable	H07RN-F3Cx1mm=x10m	53	Motor Protector 380/400/415V-50Hz.KA314-HRXL00 (H.C)	
20	Pump casing	FCD700 (EN-GJS-700-2)	54	Shaft	SUS403 (EN-X6Cr13)
21	Impeller	Urethane rubber	55	Rotor	.
23	Strainer	PVC	56	Stator	.
24	Agitator	Sintered alloy	64	Motor Frame	Aluminium die casting
25	Mechanical seal	W-14VL	68	Handle	Steel plate / natural rubber
26	V-ring	Butadiene-acrylonitrile-rubber	71	Shaft protection sleeve	SUS304 (EN-X5CrNi18-10)
29	Oil casing	FC200 (EN-GJL-200)	76	Condenser	.
30	Oil distributor	Plastic			
32	Discharge coupling	Aluminium die casting			
35	Oil screw	SUS304 (EN-X5CrNi18-10)			
36	Lubricant	Turbine oil (ISO VG32)			
50	Motor cover	Aluminium die casting			
51	Main cover	Aluminium die casting			
52A	Upper bearing	6201ZZC3			
52B	Lower bearing	6302ZZC3			